

# **Financing of Domestic Biogas Plants in China**

**Presented by**  
**Prof. Zhang Mi, Managing Director, Chengdu Energy-Environment**  
**International Corporation (CEEIC), China**  
**E-mail: zhangmij@sohu.com**

**Sponsored by the Netherlands Development Organization (SNV)**

**The International Workshop on Financing of Domestic Biogas Plants, 22-23**  
**October 2008, Bangkok, Thailand**

## **Acknowledgement**

Entrusted and sponsored by the Netherlands Development Organization (SNV), the author would like to express sincere thanks to the sponsor and the organizer of the International Workshop on the Financing of Domestic Biogas Plants in China. This report is based on the available information and data collected and contributed from the different sources in China. Hereby, many thanks go to the following government offices, institutes, universities and local domestic biogas users as well as colleagues in this fields.

- The Bureau of Science and Education, Ministry of Agriculture, Beijing
- Sichuan Provincial Office of Rural Energies, Chengdu
- Yunnan Provincial Office of Rural Energies, Kunming
- Biogas Office of Chongzhou City, Chengdu
- Yunnan Provincial Key Lab of Rural Energies, Kunming
- Institute of Solar Energy, Yunnan Normal University, Kunming
- Prof. Zhang Wudi, Yunnan Normal University
- Eng. Tang Yinghao, Rural Energy Office of Quanzhou, Guangxi Province

## Summary

This paper highlights the current status of domestic biogas development in China. In particular, it describes the breakdown of costs of the biogas plant by model, size and region, and reviews the way of financing at different areas and different levels applied so far. The focus of the description on the financial source is on the National Loan Subsidy Program (NLSP) which takes nears half of the funding for the total investment on national domestic biogas program. Due to NLSP the rapid growth of biogas development in China was realized by about 20% increasing rate per year in the last two years. Farmers are more active in building biogas digesters with the subsidy and the comprehensive benefits brought by the integrated use of biogas and bio-slurry. The different sources of financing to construct the domestic biogas digester and post-sale services are stated in detail. Cost/benefit analysis from individual household is provided with some case studies. Studies show that the impact of the national domestic biogas program has brought about a great change in the countryside not only on the rural energy for cooking and lighting but also for environment, sanitation, ecology and agriculture with obvious economic benefits. Strengths, weaknesses, opportunities and threats of such applied financial instruments are discussed with some evaluations and comments as well. It is suggested that other financial sources like credit and carbon rebate be taken for next program besides NLSP. Slow-down of the speed of the rapid growth of domestic biogas program is necessary for quality control of construction and manufacture of biogas appliances as well as for post services.

## **Table of Contents**

Abbreviations

1. Introduction and background
2. Objective, methodology and limitations of the assignment
3. Current costs of domestic biogas plants
4. Brief description of the instruments applied so far to finance domestic biogas plants
5. Overview of financing of domestic biogas plants
6. Strengths, weaknesses, opportunities and threats of the applied financial instruments
7. Conclusions and recommendations
8. References

Annexes

## **Abbreviations**

BIOMA : Biogas Research Institute, Ministry of Agriculture

BRTC: Asia-Pacific Regional Biogas Research & Training Center, Chengdu, China

CEEIC: Chengdu Energy-Environment International Corporation China

CNY: Chinese Yuan

DEWATS: Decentralized Waste Water Treatment System

Five-in- One: Biogas digester, Animal stall, Solar heater, Water stove and Fruit garden

Four-in-One: Greenhouse, Vegetable, Pig stall and Biogas digester

LAP: International Assistance Program

LGSP: Local Government Subsidy Program

MOA: Ministry of Agriculture

MOF: Ministry of Finance

MSW: Municipal Solid Waste

NLSP: National Loan Subsidy Program

SCDR: State Commission of Development and Reform

SDB :Self-investment Domestic Biogas

SNV: the Netherlands Development Organization

## **1 Introduction and background**

### **1.1 The development of domestic biogas program in China**

Biogas was discovered and recorded by people in China hundreds of years ago and man-made biogas commenced in the end of 19<sup>th</sup> century (Fig.1). In the 1920's, scientific demonstration with Mr Luo Guori's Model appeared (Fig.2). In the late of 1970's, massive hydraulic biogas digesters were popularized in the country soon after the former president Mao Zedong's call. In the middle of 1980's, the standard design of domestic hydraulic biogas digester was issued and popularized in China and extended to other developing countries (Fig.3) as well.

Since 2002 after the Chinese government stress the importance and benefits of biogas like Mr Wen Jiabao, the Prime Minister saying “ Developing biogas is not only beneficial to solving farmers' energy for life, but also beneficial for protecting ecology and

environment, which is really a very significant and perspective infrastructure for public welfare. ...”. Since then, the domestic biogas program has been put in the government policy as a part of rural infrastructure saying “ Road, Biogas, Water, Electricity and Communication”. Consequently, national domestic biogas program (NDBP) was largely planned and developed rapidly. In the meantime, the model and construction materials have been modified to be more reasonable, more scientific, more economic and more practical and efficiency like some commercial biogas plants such as fiber glass biogas digesters (Fig.1.4) etc.

By the end of 2007, the total number of household biogas digesters in rural areas of China was about 26.5 millions with the total gas yield 7.95 billion m<sup>3</sup> compared with 18 millions in 2005. It is targeted by the state that the total number of domestic biogas plants will reach 84 millions by the end of the year 2020, which will account for 70% of 120 million of the total number of potential biogas households. The growth rate per year in the past two years was more than 20% i.e. more than 8 million of household biogas digesters were constructed in rural areas of China. Taking Sichuan province for example, by the end of 2006, the total number of the domestic biogas digesters was 3.4 millions while 3.95 million for 2007. The rapid growth of such development has effectively changed the condition of rural status of energy, environment, sanitation and ecology with the improvement of toilet, pig sty and kitchen as well as integrated use of biogas and bio-slurry. Meanwhile, the farmers’ life and economy have been much enhanced.

As for the size of the domestic biogas digester in China, most populated is 6 m<sup>3</sup> to 8 m<sup>3</sup> and some are 10 m<sup>3</sup> . The model is the standard hydraulic type underground made with cement and bricks, some are cast-in-place, some are prefabricated concrete, some are prefabricated fiber glass, some are of soft materials like special plastic etc. The digester is normally connected to the pig sty, toilet which is named “ Three- in-One ” integrated model.

The cost of the standard household biogas digester with all the necessary equipment is ranged from 1800 CNY (264USD) to 3000 CNY(441USD) currently taking a 6 m digester for example subject to the region with different natural conditions and labor cost, type of model and building materials as well as equipment etc. For instance, a typical household biogas digester made of cement and bricks in the suburb of Chengdu, Sichuan province costs about 2000 CNY(294USD) while it costs about 2500 CNY(367USD) in the other provinces like Shanghai, Guangdong etc.

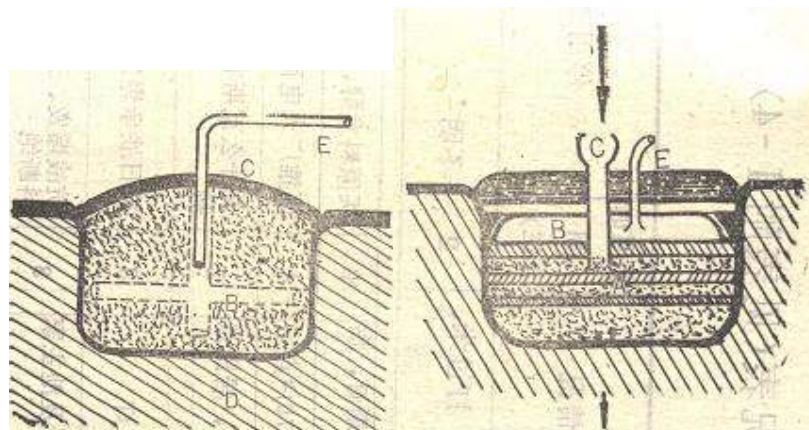

**Fig.1 The earliest biogas digester in China**

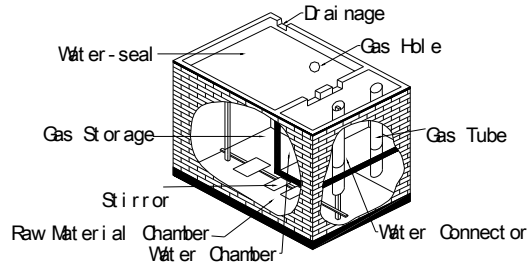

**a. Rectangular gas reactor**

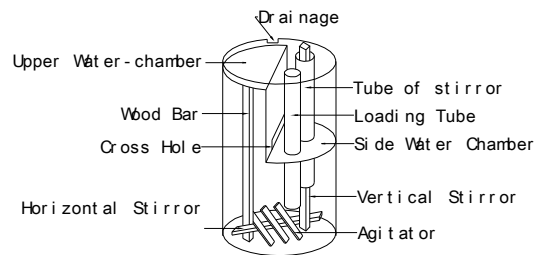

**b. Cylinder type gas reactor**

**Fig. 2 Mr Luo Guori's Gas Reactor (Biogas digester)**

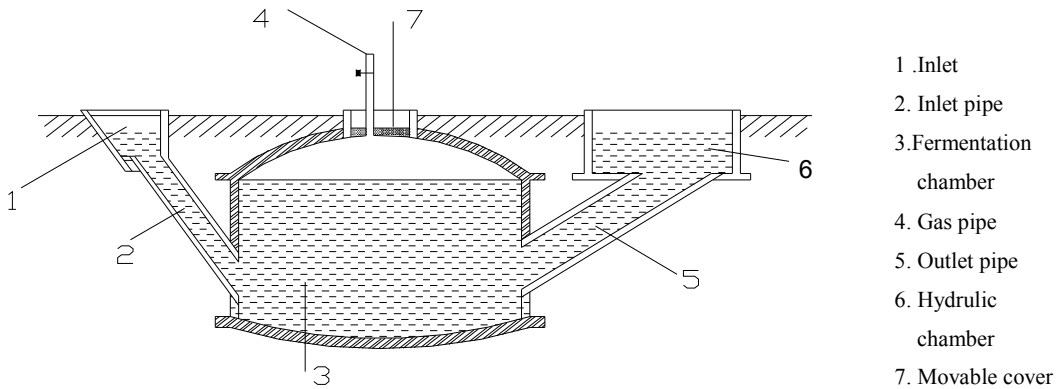

**Fig. 3 Structure sketch of the standard hydraulic biogas digester**



**Fig. 4 Commercialized biogas digesters of fiber glass**

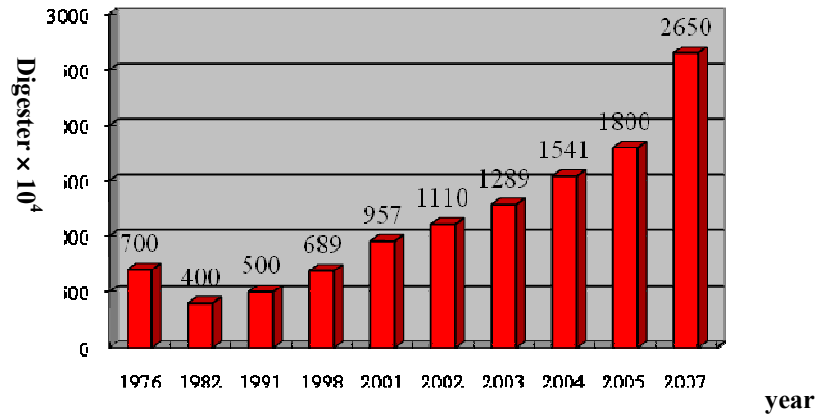

**Fig. 5 The development of biogas in rural areas of China**

## 2. Objective, methodology and limitations of the assignment

The dissemination of domestic biogas digesters in China has taken several stages since the 1970's. Many factors are involved in affecting the dissemination work. Besides science and technology, government policy and farmer's awareness are also important. Among all the factors, financing stands in the first place for such dissemination work as many farmers are keen on economic benefits rather than other benefits. The objective of this assignment is to give a breakdown of the current costs of the biogas digester, an overview of the financing instruments, a cost/benefit analysis and assessment of the strengths, weaknesses, opportunities and treats(SWOT) of such financing instruments applied so far in China for the NDBP program. Problems and suggestions are also discussed for future improvement.

The methodology for preparing this paper is by collecting first-hand and some secondary information from government offices, institutions, biogas companies and users at some selected provinces and counties as well. Field visits to some rural household biogas users with face to face talk were also conducted at some villages in Sichuan and Yunnan provinces.

There also exists some limitations such as the information is only limited to some areas but not covering the whole country, like some remote places or mountainous regions, minority regions, very poor regions not in this study.

## 3. Current costs of domestic biogas plants

The cost of the standard household biogas digester with all the necessary equipment is ranged from 1800 CNY to 3000 CNY currently taking a 6 m digester for example subject to the region with different natural conditions and labor cost, type of model and building materials as well as equipment etc. For instance, a typical household biogas digester made of cement and bricks in the suburb of Chengdu, Sichuan province costs about 2000 CNY while it costs about 2500 CNY to 3000 CNY in the other provinces like Shanghai, Guangdong and Tibetan etc. The breakdown of the cost is shown below taking traditional cement-bricks hydraulic biogas digester of 8 m<sup>3</sup> for instance. .

**Table 1 Breakdown of the cost of a 8 m<sup>3</sup> household biogas digester in Sichuan province China (Currency: CNY )**

Item	Specification	Unit price	Quantity	Sum (CNY)	Accounting for (%)
<b>1.Materials</b>				1781.00	<b>61</b>



Cement	325 #	700/t	1.2t	840.00	
Sand	Medium	120/m <sup>3</sup>	1.5 m <sup>3</sup>	180.00	
Bricks		0.4/pie.	1500pie.	600.00	
Gravel	Φ1.5-2cm	100/m <sup>3</sup>	0.2m <sup>3</sup>	20.00	
Steel bar	Φ10cm	4.0/kg	30kg	120.00	
Painting		7/kg	3kg	21.00	
<b>2. Appliances</b>				<b>375.00</b>	<b>13</b>
Stove	Single	75/pie.	1pie.	75.00	
Lamp		35/set	1pie	35.00	
Pipe		2.5/m	50m	125.00	
Gas pressure meter		28/pie.	1pie.	28.00	
Water trap		8/pie.	1pie.	8.00	
De-sulfuring device		48/set	1set	48.00	
Switch	Copper	4/pie	4pie.	16.00	
Joints & fixers		1/pie.	40pie.	40.00	
<b>3. Labor</b>				<b>770.00</b>	<b>26</b>
Skillful		70/day	7days	490.00	
Un-skillful		40/day	7days	280.00	
<b>4. Overhead</b>					Included
<b>Total</b>				<b>2,926.00</b>	

**Total cost : 2,926 CNY = 430USD (1USD = 6.81CNY)**

**Table 2 Breakdown of the cost of a 6 m<sup>3</sup> household biogas digester made of fiber glass at Anning County, Yunnan province (Currency: CNY)**

Item	Specification	Unit price	Quantity	Sum (CNY)	Accounting for (%)
<b>1. Digester</b>				<b>2,500.00</b>	<b>82</b>
From manufacture	6 m <sup>3</sup>	2,300/set	1set	2,300.00	
Transportation		200/set		200.00	
<b>2. Appliances</b>				<b>375.00</b>	<b>12</b>
Stove	Single	75/pie.	1pie.	75.00	
Lamp		35/set	1pie	35.00	
Pipe		2.5/m	50m	125.00	
Gas pressure meter		28/pie.	1pie.	28.00	
Water trap		8/pie.	1pie.	8.00	
De-sulfuring device		48/set	1set	48.00	
Switch	Copper	4/pie	4pie.	16.00	
Joints & fixers		1/pie.	40pie.	40.00	
<b>3. Labor</b>				<b>180.00</b>	<b>6</b>
Skillful		100/day	1days	100.00	
Un-skillful		40/day	2days	80.00	
<b>4. Overhead</b>					Included
<b>Total</b>				<b>3,055.00</b>	

---

**Total cost : 3,055 CNY = 449USD (1USD = 6.81CNY)**

---

#### **4. Brief description of the instruments applied so far to finance domestic biogas plants**

In China the domestic biogas program was launched early in 1958 as called by the late Chairman Mao Zedong. Due to very poor science and technology, mainly on proper design, building materials and fermentation knowledge and management, the program ran just for a very short time. As for the financing of the biogas plant, it was mainly from the government subsidy with some part of cost from users. But most of such plants were for demonstration purposes.

The second period of the national domestic biogas program was in the 1970's up to early 1980's due to oil crises in the world and rural energy shortage in some parts of the country like Sichuan and Hunan provinces etc. Large mass movement on domestic biogas plant construction was seen in the central, southwest, southeast parts of China. At that time, the rural economic system was in the form of community called "People's Commune", which was directly under the county and covered production brigades and production teams as the lowest levels. So the biogas plant was built and financed mainly by the production team as community responsibility, all the building materials appliances and labor were provided by the production team as the team's contribution. Huge quantity (7 million) of domestic biogas digesters was hit to the record but many of the digesters were of poor quality, which defamed biogas work.

From the middle of the 1980's up to the end of 1990's China was on the way of "Economic Reform and Opening to the World" taking rural community as a pattern. People's Communes were dismissed while towns, townships, villages and villager groups appeared. The national domestic biogas program was adjusted with stressing of science and technology, daily management and integrated use of biogas and bio-slurry, which was resulted in great progress such as the implementation of the standard design of rural household biogas digesters, the standard of construction operation and quality control etc. For the financing of the digesters during this period, there were several modes for the promotion of domestic biogas plants. In most cases the financing was mainly from the user's themselves with some subsidy by the government. But this subsidy was not in cash, but in kind or in land use. In some areas like Sichuan province the local government issued a favorable policy which stipulated that "Those who build a biogas digester can get 0.2 mu (about 120 m<sup>2</sup>) more of land for use". At that time one person of a farmer's household usually got 40 m<sup>2</sup> for housing in Sichuan. In Guangxi province the local government supplied all cement needed to the user as subsidy, which accounted for about 30% of the total cost. At that time the total cost of a 6 m<sup>3</sup> digester cost about 1000 to 1200 CNY. While in some areas the government gave free technical and labor services to the users as subsidy.

From the early 2000 up to the present the national domestic biogas program has opened a new page in history under the Chinese government new policy which put biogas construction as a part of rural infrastructure as the government has realized the multi-benefits of biogas to the rural development. Under

this program called as “National Loan Subsidy Program” in rural areas (NLSP) was launched and huge budget was planned and allocated by the central government. For instance, 1 billion CNY was put in the NDBP program in 2006 while 2.5 billion CNY in 2007 for the whole country. In Sichuan province 72.2 million CNY was allocated in 2005, 100 million CNY in 2006 and 176 million CNY in 2007. Besides NDBP, other sources of government financing at different levels were also available from provincial, municipal and county levels. For example, only in Sichuan 150 million CNY from provincial level was put in rural domestic biogas program last year. In addition, other funding sources from international organizations as aid took a small part of the work such as funding from the Netherlands and Japan governments. In the past few years, for instance, there was a Japanese government assistance program for promoting rural domestic biogas in 10 counties of Sichuan province. In this program 3000 to 3600 CNY contribution for each household with the loan of Japanese Yen was implemented with success. Moreover, some other financing modes for domestic biogas plants were also implemented in China during the past few years. There were various kinds of low interest, discounted and small amount of credit from the bank were carried out in some provinces for the construction of the domestic biogas plants. In some other cases without the national loan subsidy nor local government subsidy, the user approach the local biogas office or company directly to ask for building the biogas digester and pay completely by themselves. Of course, most of them have a certain amount of animals and are able to afford in one time.

## **5 . Overview of financing of domestic biogas plants**

### **5.1 Sources of financing**

#### **---National Loan Subsidy Program (NLSP)**

Since 2003 the national loan subsidy program (NLSP) was initiated for rural biogas development in China, which took the biogas digester as a linkage in line with improved toilet, animal stall and kitchen as well. The objective is to adopt the combination of energy utilization and control pollution, get better rural ecology and environment, promote rural development, and bring multi-benefits to the farmer to get rich. Based on the different areas in the country, the subsidy was divided into three classes, i.e. 800 , 1000 and 1200 CNY. And the NLSP investment was from 1billion CNY in 2003 up to 2.5 billion CNY in 2006 and onwards. According to the statistic up to April 2008, the completion rate of the construction of NLSP was 98.73% in average in contrast with less than 56% in some provinces against the projected, 98.94% in 2004 with less than 8% in few provinces , 93.7% in 2005 with less than 53% in a few provinces and 49.86% in average while in a few provinces it was less than 1%. The big difference of such implementation rate was due to many factors like the improper conditions of the selected households, the poor management of the local biogas offices and the unavailability of the funding itself etc.

The process of implementation of NLSP is as follows. The total budget is made jointly by the Ministry of Agriculture (MOA) and the State Commission of Development and Reform (SCDR), and approved by the Ministry of Finance (MOF) every year. Then the funding is distributed to the Bureau of Finance of different provinces down to different regions and counties. The bureaus of finance at different levels keep the funding and pay to the biogas user with the majority of the subsidy in kind like the building materials and equipment with only a small amount in cash for the reimbursement of some materials or labor, which is normally through the management of the local biogas offices. For instance, 1000 CNY was subsidized to the user in Sichuan province with 700 to 800CNY paid for materials and appliances and 200 to 300 CNY for labor in some cases. The subsidy is only paid upon the

delivery of qualified biogas digester built

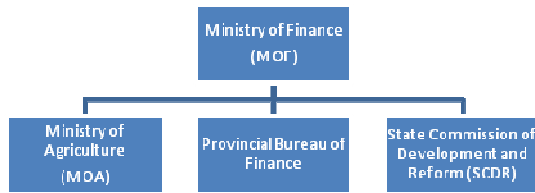

**Fig. 6 Structure of funding source from NLSP**

**---Local Government Subsidy Program(LGSP)**

Besides the National Loan Subsidy Program (LGSP), the other financial subsidy sources were from the local government at provincial and municipal levels. For example, in Sichuan province there was 150 million CNY as subsidy for domestic biogas program in 2007. The implementation and management of such financing is similar to NLSP and the amount of such subsidy is usually ranging from 200CNY to 400CNY per household. And one household can not benefit from both subsidies, only takes one of the two.

**---International Assistance Program(IAP)**

For some special cases of domestic biogas program in China with international financial aid like from Japan or the Netherlands government, the amount of subsidy to each household is comparatively higher than the subsidy from LGSP. According to the government to government agreement some poor areas were chosen on special energy programs of solar, biogas and small hydro-power etc. For instance, 3600 CNY was planned and paid to each household who is beneficiary of the project assisted by the Japanese Yan Loan Program a few years ago in Sichuan.

**---Self-investment Domestic Biogas (SDB)**

The Self-investment Domestic Biogas (SDB) means the user actively plans to build his/her own biogas digester at his own cost, either through low-interest (2% to 3% yearly), discount interest or small amount loan/credit from the bank without any subsidy from the government. Usually such users are comparatively rich and have enough animals to produce biogas like pigs which cause pollution to environment. The multi-benefits of biogas and bio-slurry attract the user to build biogas plants.

**5.2 Farmer's contribution**

As far as the farmer's contribution to the construction of the domestic biogas digester as concerned, it can be traced back from the 1980's. For a 6 m<sup>3</sup> household biogas digester during the 1980's to the 1990's in China, the complete cost of the digester was from 1000 CNY to 1500CNY subject to the different areas or regions. At that time there was neither National Loan Subsidy Program (NLSP) nor Local Government Subsidy Program (LGSP). The farmer sometimes got some subsidy in kind from the local government like additional land use, cement donation from the local government or international aid from some international projects in some cases. The farmer usually excavated the digester pit with his own family labor or by other unskillful labors, made a contract with the local biogas company and payment to the company for the complete job upon the handover of the digester, which was tested water-proof and gas-proof. The company was responsible for supply and install of all the biogas appliances in line with the construction of the digester. In some areas, the technician or the labors had meals at the farmer's home free of charge.

Since 2003 the NLSP was launched in China the farmer only pays half of the total cost in most of areas. For instance, at the Chongzhou city of Chengdu, Sichuan province a 8 m<sup>3</sup> prefabricated biogas digester at present costs about 2000 CNY but the farmer pays only 1000 CNY with 50% subsidy from government. But there are some areas with more favorable policy which gives more than 50% subsidy to the farmer like Guangxi province and Chongqing. In Guangxi, now the government pays all cost to the user while in Chongqing about 65% to 70%. The subsidy usually covers labor and some materials or appliances. If the farmer wants to dig the digester pit by himself, he can saves about 200 CNY from the excavation, which means he can pay only 800 CNY to the biogas company according to the Chongzhou Biogas Office.

**Table 3 Different sources of financing in different regions**

Region	NLSP (Subsidy)	LGSP (Subsidy)	IAP (Donation)	SDB (By user)	Remarks
Sichuan	50%	20-30%	100%	100%	
Yunnan	50%	20-40%	100%	100%	
Chongqing	70%	30-50%		100%	
Guangxi	90%	40-70%		100%	
Guizhou	60%	30-50%	100%	100%	

Note: The above percentage means the amount of funding for each biogas household.

### 5.3 Credit and carbon rebate

In some areas or cases the farmers can not access the program of government subsidy for biogas digesters but they need to build the digesters, they either pay in cash directly to the biogas company/constructor, or take credit from the bank for installment of low-interest, non-interest or discount. This is normally done through the Agriculture Bank or its agencies which gives favorable loan for agricultural development.

Until now for the domestic biogas program in China has not got carbon rebate (CDM) but some researchers and management officials are putting this matter into agenda for study as CDM has been introduced to some big biogas plants and projects with good economic benefits.

### 5.4 Cost/benefit analysis

The study of cost/benefit analysis of domestic biogas plants has been carried out in different provinces like Yunnan, Sichuan, Guizhou and Guangxi with similar impact. The following models show some typical use of domestic biogas in the northern parts and in the southern parts of China respectively.

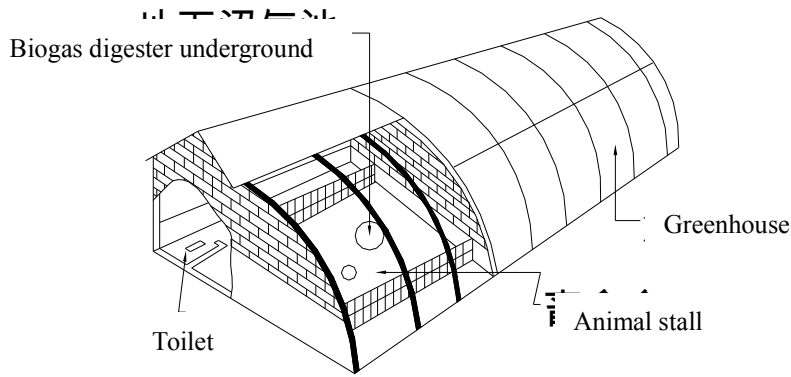

Fig. 7 "Four-in-One" biogas model

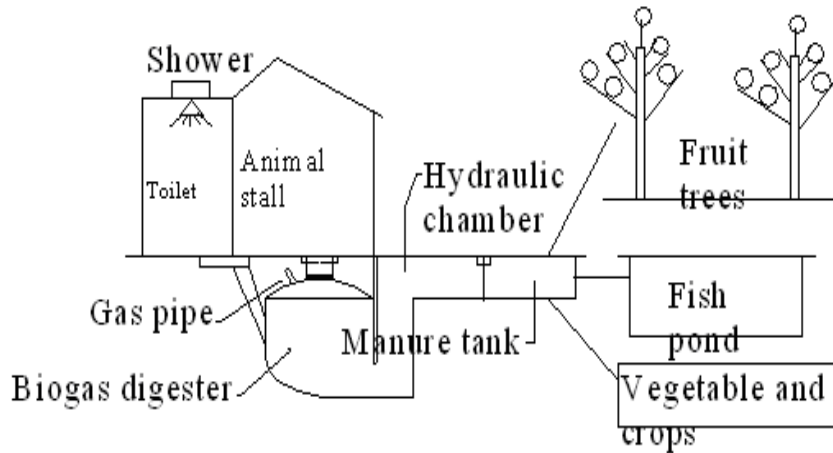

Fig. 8 "Pig sty - Biogas digester - Fruit trees" Model

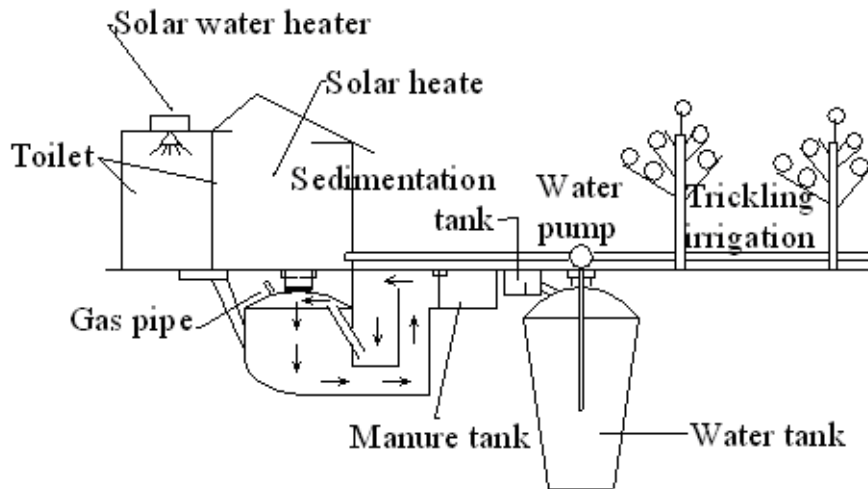

Fig. 9 "Five-in-One" Eco-Orchard System

Taking Zhenan County of Guizhou Province as an example, the cost of a 8m<sup>3</sup> digester is 1800 CNY (Note: This is a very low cost as this county is a very poor county where the price of labor and building materials is low.) , the subsidy from the government is 500 CNY, and the farmer will pay 1300CNY, which can be credited from the bank with 100 to 200 CNY discount. If they put the improvement of toilet, pig sty and kitchen with

courtyard integrated with the digester, the total investment is about 3500 CNY to 4000 CNY. With the government integrated subsidy program the user pays only about 1500 to 2000 CNY. For the payback in one year, the user may get 1800 CNY from saving energy of coal and reducing time of cooking for other business. If using bio-manure as organic fertilizer, about 2000 CNY may be earned from reducing cost of chemical fertilizer and increasing crop production per year. If a digester can serve for 20 years the farmer may get about 100,000CNY. Taking out the management and maintenance cost, the net income is still over 80,000 CNY, which revealed the advantages of domestic biogas.

Due to the remarkable benefits from the domestic biogas digester this county has fulfilled its target of domestic biogas extension in one year. Only in Pingan Village of Bifeng Township the target was 120 digesters, but they have built 240 digesters in one year.

The economic benefits are not only from energy but from the integrated use of bio-slurry with development of court-yard economy, which fully reveal the role of biogas digester to animal husbandry and eco-farming system. Meanwhile, the mode of “Animal husbandry—Biogas digester---Food (fruits, vegetables, tea etc.)” has formed a closed eco-husbandry mode with biogas digester to promote animal husbandry, and vice versa. At Xinzhuang Village Anchang Township there are 115 households, 100 of which have built biogas digesters. At the same time they have built 7 regions for animal husbandry with 680 pigs, 120 cows and 2460 poultry and 360mu (1hectare =15mu) land of fruit gardening. The comprehensive utilization of biogas and bio-slurry brings the net income for each household over 4000 CNY per year. Here is the case study for a domestic biogas digester of 6 m<sup>3</sup> in Sichuan province.

### 5.5 Case study of a 8 m<sup>3</sup> household biogas digester in 2008

1). Cost : ( 1USD=6.81CNY )

**Table 4 Cost of a 8 m<sup>3</sup> household biogas digester in 2008**

Item	Specification	Unit price	Quantity	Sum (CNY)	Remarks
<b>1.Materials</b>					
Cement	325 #	700/t	1.2t	840.00	
Sand	Medium	120/m <sup>3</sup>	1.5 m <sup>3</sup>	180.00	
Bricks		0.4/pie.	1500pie.	600.00	
Gravel	Φ1.5-2cm	100/m <sup>3</sup>	0.4m <sup>3</sup>	40.00	
Steel bar	Φ10cm	4.0/kg	30kg	120.00	
Painting		7/kg	3kg	21.00	
<b>2.Appliances</b>					
Stove	Single	80/pie.	1pie.	80.00	
Lamp		40/set	1pie	40.00	
Pipe		3.0/m	50m	150.00	
Gas pressure meter		30/pie.	1pie.	30.00	
Water trap		10/pie.	1pie.	10.00	
De-sulfuring device		50/set	1set	50.00	

Switch	Copper	5/pie	4pie.	20.00	
Joints & fixers		1/pie.	40pie.	40.00	
Others				40.00	
<b>3. Labor</b>					
Skillful		70/day	7days	490.00	
Un-skillful		40/day	7days	280.00	
<b>4. Overhead</b>					Included
<b>Total</b>				<b>3,061.00</b>	

## 2). Benefits

### (1). Energy (biogas)

$1.5\text{m}^3/\text{d.} \times 365\text{d.} = 547\text{m}^3/\text{year.}$  ( The average gas production may be higher.)

- $547\text{m}^3 \times 2.0\text{CNY}/\text{m}^3 = 1094\text{CNY}/\text{year}$  ( Unit price of gas is  $2\text{CNY}/\text{m}^2$ .)
- (2). Bio-fertilizer
- Crop yield increased by 10-15%
- Soil quality (fertility and structure) enriched by 5-10%
- (3).Sanitation improved (disease reduced)
- (4).Ecology protected (deforestation )
- (5).Women's labor released
- (6).Saving more time for other activities
- **3). Payback period**
- (1). Direct from energy
- Cost / yearly income
- =  $3061 / 1094$
- $\geq 3\text{years}$
- (2). Taking the other benefits into account, the payback period is shorter by 30-50% to about 1.5 - 2 years.
- (3). If 30 - 50% or more of the initial cost is by subsidy from government, which means the farmer pays only 1500 to 2000 CNY, then normal payback time is only 1 to 2 years subject to the adoption of comprehensive utilization and the local conditions.
- (Note: The interest of funding, depreciation of the digester and appliances, maintenance cost are neglected.)

## 6. Strengths, weaknesses, opportunities and threats (SWOT) of the applied financial instruments

As far as the mode of the Chinese domestic biogas plants as concerned, the instruments of financing for investment at present mainly from government subsidy policy (National Loan Subsidy Program and local government subsidy programs etc.) as an incentive to the farmers. The other instruments of financing like credit from the bank takes a small part of the program. Carbon rebate for national program will be put into agenda soon. The following table lists the strengths, weaknesses, opportunities and



threats of the applied financial instruments.

### **Evaluation of the financial instrument (investment subsidy)**

#### **Strengths:**

1. The awareness of developing biogas from farmers and society is going up sharply and biogas benefits have been popular with people. For the NLSP/LGSP program, it is a huge government investment for the rural development as a part of infrastructure. So the increase rate of domestic biogas digesters are going up sharply and biogas is giving full impact to the renewable energy, environment protection and eco-farming system for sustainable rural development etc.
2. As the financing instrument of NLSP/LGSP is centralized and managed by the government, it is good for extension of biogas technology and standardizing design of digesters, appliances and quality control, and it guarantees financing for sustainable development as it is developed in a planned way in combination with the market economy. If it only depends on the market, it is difficult to promote a number of private enterprises without govt. favorable policies and many farmers would not be so active to build the digester subject to the price of local fuels.
3. With about 50% or more subsidy from government the user (farmer) is more incentive and active to build the biogas digester and make full use of biogas and bio-slurry to get more benefits.
4. In view of the national planning, it makes easier to make a total program, propaganda, training and promotion as well as coordination with manufacturing and construction companies for a long term planning.
5. In case of any problems, it is better to take measures than without such instrument.
6. Providing a huge number of biogas workers for employment;
7. Rural energy, sanitation and ecology situation get much improved;
8. Women users get much time to do other business;

#### **Weaknesses:**

1. The quick development by the government in domestic biogas extension will bring some problems of digester construction quality, the guarantee of performance due to insufficient fermentation raw materials like lack of animal waste and poor management etc.;
2. The period of implement the financing seems too long. It must take several steps from propaganda—application—site selection--approval—construction—check and acceptance—filing record—reimbursement;
3. Without subsidy it will become difficult to promote domestic biogas plants in a big stride;
4. On the contrary, with subsidy especially with majority of subsidy the user may not take good care of the plant;
5. It gives some difficult for the local biogas office to manage as the users are not so concentrated, especially in mountainous areas;

#### **Opportunities:**

1. International assistance to cover the financing part which the farmer should pay by themselves for some poor areas may improve the functioning of the instrument as

- in additional subsidy in line with credit ;
2. International mode of management and standardizing for construction and appliances may be introduced;
  3. Carbon rebate (CDM) should be a very strong promoter to improve the functioning of the instrument and bring more benefits in economy;
  4. Exchange of information and international cooperation with internal and external parties are useful to this kind of financing instrument for promotion;

**Threats:**

1. The reduction of animals for farmer households will inhibit the number of potential biogas users due to more and more farmer going out for work, which could make the instrument of financing non-functioning;
2. Un-stability of biogas technicians and workers will cause uncertain of construction progress and quality due to income;
3. Change of government policy is the main inhibition factor to the instrument of financing;
4. China's economy growth and policy will also affect the "National Loan Subsidy Program"(NLSP) and" Local Government Subsidy Program"(LGSP);

**Other problems**

1. In some less developed areas the local government can not afford the funding for biogas program in line with NLSP;
2. The potential users are decentralized, which are difficult to approach for propaganda and technical instruction and management;
3. Lack of labor as many young people work outside;
4. Poor farmers are unable to pay for their own parts besides subsidy; (It's a possibility for linking with credit services might be more useful);
5. Post service and management after construction
6. Poor quality mainly on biogas appliances like stoves and lamps as well as pipes and de-sulfuring devices

**7. Conclusions and recommendations**

This paper describes the overall of the modes and instruments of financing in domestic biogas plants in China, which focuses on the "National Loan Subsidy Program"(NLSP). The main reason is that the Chinese government pays much attention to the rural development while biogas takes a very important part in the rural infrastructure. Only relying on the market economy biogas can not develop so fast due to economic reason of farmers in many areas. But in some developed areas where farmers are aware of biogas and its benefits, they may afford to build the digester and manage it well. The NLSP takes the leading way to promote biogas development in China growing up rapidly and stably. The other financial sources are also tangled in this paper. The main advantages of the NLSP have revealed that biogas is a good solution to rural energy, environment, sanitation and eco-farming as well as for reducing labor for women and children. Consequently, the economic benefits are

shown in the study with normal payback time much shorter, i.e. 1 to 3 years with the increasing of commercial fuel prices. The positive impact is clear but some problems and constraints are also existing, which should be paid much attention to. It is expected that the pace for the national domestic biogas program be slowed down for better quality and stable and sustainable development.

It is suggested by some experts and local biogas offices as follows.

1. Increasing the subsidy proportion (eg. 1500CNY/household for NLSP and 1000CNY/household for local government subsidy) : Enhancing the standard of subsidy as the remained farmers are too poor to afford by themselves.
2. Ensuring management fee: Either direct take from the NLSP in proportion or the local government allocate the amount needed to the biogas office first before implementation of NLSP.
3. Helping the farmer to dig the digester pit and preparing raw materials (animal waste) for fermentation with fixed supplier to transport the materials and appliances to the user, and control the quality in a centralized way.
4. Strengthening the R&D in new materials and new users;
5. Due to lack of fermentation raw materials, the digester is sometimes in hunger state. The post service like maintenance and checking appliances are necessary. The biogas service/management company or station should be extended.

## **8. References**

1. “Management measures on rural biogas program with national loan”, Zhang Shuyong&Liu Shenyong, China Biogas 2008,26 (3)
2. “Problems and suggestions on rural biogas program with national loan”, Li Jun, China Biogas 2008,26(3)
3. “Plan on energy-ecology construction in Quanzhou 2008” , Rural Energy Office, Quanzhou County, Guangxi province
4. “Collection of materials on biogas program with national loan in Sichuan”, Nov.2007

