



Facilitating Sustainable Mountain Tourism

Volume 1: Resource Book

Editors

Ester Kruk, John Hummel, and Kamal Banskota



About the Organisations

International Centre for Integrated Mountain Development

The International Centre for Integrated Mountain Development (ICIMOD) is an independent regional knowledge, learning and enabling centre serving the eight regional member countries of the Hindu Kush-Himalayas – Afghanistan 🇦🇫, Bangladesh 🇬🇧, Bhutan 🇧🇹, China 🇨🇳, India 🇮🇳, Myanmar 🇲🇲, Nepal 🇳🇵, and Pakistan 🇵🇰 – and the global mountain community. Founded in 1983, ICIMOD is based in Kathmandu, Nepal, and brings together a partnership of regional member countries, partner institutions, and donors with a commitment for development action to secure a better future for the people and environment of the Hindu Kush-Himalayas. ICIMOD's activities are supported by its core programme donors: the Governments of Austria, Denmark, Germany, Netherlands, Norway, Switzerland, and its regional member countries, along with programme co-financing donors. The primary objective of the Centre is to promote the development of an economically and environmentally sound mountain ecosystem and to improve the living standards of mountain populations.

SNV Netherlands Development Organisation

SNV Netherlands Development Organisation is a Netherlands based international NGO that delivers capacity building advisory services to over 1,800 clients in 33 countries in Africa, Asia, Latin America and the Balkans. In Asia, SNV provides capacity building services to government, non-government and private sector organisations in Nepal, Vietnam, Bhutan, Laos, Cambodia and Bangladesh as well as to a number of regional organisations and networks. Our 150 advisors in Asia work with local actors, primarily those who operate at national and meso levels in strengthening their capacity to effectively realise poverty reduction and good governance.

Nepal Tourism Board

The Nepal Tourism Board (NTB) is a national organisation established in 1998 by an act of parliament in the form of a partnership between the Government of Nepal and private sector tourism industries to develop and market Nepal as an attractive tourist destination. The NTB provides a platform for vision-drawn leadership for Nepal's tourism sector integrating government commitment with the dynamism of private sector tourism industries. NTB promotes Nepal in domestic and international markets and is working toward repositioning the image of the country. In future, it aims to regulate product development activities. NTB maintains financial independence through funding derived from the Tourist Service Fee levied on departing foreigner passengers at Tribhuvan International Airport, Kathmandu. The Board has 11 members – five government representatives, five private sector representatives, and the chief executive officer – and is chaired by the Secretary of the Ministry of Culture, Tourism and Civil Aviation.

Facilitating Sustainable Mountain Tourism

Volume I – Resource Book

Editors

Ester Kruk, John Hummel, and Kamal Banskota

International Centre for Integrated Mountain Development (ICIMOD)

Kathmandu, Nepal

October 2007

Copyright © 2007

International Centre for Integrated Mountain Development (ICIMOD)
All rights reserved

Published by

International Centre for Integrated Mountain Development
G.P.O. Box 3226
Kathmandu, Nepal

ISBN 978 92 9115 056 4 (printed)
978 92 9115 057 1 (electronic)

Cover photos: Front: Namtso Lake, Tibet Autonomous Region, China; people from around Inle lake and Bagan, Myanmar – *Ester Kruk*
Back: Tourist crossing the suspension bridge over the Dudh Koshi, Solukhumbu, Nepal – *Celine Curi*, (insets) Tourism training – *Ester Kruk*

Editorial team

Susan Sellars-Shrestha (Consultant Editor)
Greta M. Rana (Consultant Editor)
A. Beatrice Murray (Senior Editor)
Dharma R. Maharjan (Layout Design)

Printed and bound in Nepal by

Hill Side Press (P) Ltd.
Kathmandu

Reproduction

This publication may be reproduced in whole or in part and in any form for educational or non-profit purposes without special permission from the copyright holder, provided acknowledgement of the source is made. ICIMOD would appreciate receiving a copy of any publication that uses this publication as a source.

No use of this publication may be made for resale or for any other commercial purpose whatsoever without prior permission in writing from ICIMOD.

Note

The views and interpretations in this publication are those of the authors. They are not attributable to ICIMOD, SNV, or NTB and do not imply the expression of any opinion concerning the legal status of any country, territory, city or area of its authorities, or concerning the delimitation of its frontiers or boundaries, or the endorsement of any product.

This publication is available in electronic form at <http://books.icimod.org>

Contents

Foreword
Acknowledgements
Acronyms and Abbreviations

PART 1: INTRODUCTION

Chapter 1: Introducing this Resource Book	3
Introduction and Background of the Resource Book	3
Guiding Principle of the Resource Book	4
Resource Book Flow	5
Regional and Mountain Perspective	5
Structure and Overview of the Resource Book	6
Intended Use of the Resource Book	6
Chapter 2: Project Cycle Facilitation	7
Introduction: Project Cycle Facilitation in Sustainable Mountain Tourism	7
A Framework for Tourism Project Cycle Facilitation	8

PART 2: OVERVIEW OF CONCEPTS

Chapter 3: Overview of Tourism	19
Introduction: Concepts and Definitions of Tourism	19
Tourism: Dynamism and Growth	21
Overview of International Tourism	22
Tourist Arrivals in the South Asian Region	24
Tourism and the World Economy	25
Impacts of Tourism	26
Major Issues and Constraints	28
Chapter 4: Concepts and Principles of Sustainable Mountain Tourism	31
Introduction: Sustainable Development and Mountain Tourism	31
Tourism Carrying Capacity and Limits of Acceptable Change	35
Pro-Poor Tourism (PPT) as a New Approach to Sustainable Tourism	41
Chapter 5: Sustainable Mountain Tourism Planning and Management	45
Introduction: Imperatives of Mountain Tourism Planning	45
Components of a Tourism Plan	46
The Tourism Planning Process	48
Framework for Monitoring Sustainability of Mountain Tourism	53

PART 3: OVERVIEW OF APPROACHES

Chapter 6: Participatory Planning and Organisation	57
Introduction: The Importance of Participation in Sustainable Mountain Tourism	57
Participatory Approaches in Sustainable Mountain Tourism Development	59
Participatory Planning and Organisation Tools	66
Chapter 7: Multi-Stakeholder Collaboration	71
Introduction: The Need for Multi-Stakeholder Collaboration	71
Multi-Stakeholder Processes in Sustainable Mountain Tourism	71
Lessons Learned in Tourism Multi-Stakeholder Collaborations	76
Chapter 8: Gender and Social Inclusion	83
Introduction: Challenges for Women in Mountain Tourism	83
Concepts of Gender Mainstreaming and Social Inclusion in Tourism	85
Mainstreaming Gender and Social Inclusion in the Tourism Project Cycle	88
Monitoring and Evaluation in Sustainable Mountain Tourism	90
Chapter 9: Tourism Enterprise Development and Market Linkages	93
Introduction: Enterprise Development in the Tourism Economy	93
Step-by-Step Guide to Sustainable Mountain Tourism Enterprise Development	94
Chapter 10: GIS for Planning and Development	107
Introduction: GIS in Tourism	107
GIS for Sustainable Mountain Tourism Planning and Development	108
Potential GIS Applications in Mountain Tourism	109
The Future Role of GIS in Sustainable Mountain Tourism	112
Chapter 11: Monitoring and Evaluation	113
Introduction: The Need for Monitoring and Evaluation	113
Definition of Monitoring and Evaluation	114
How to Monitor and Evaluate Tourism Projects and Programmes	115
Evaluation in Tourism Project Cycles	117
Monitoring Sustainable Mountain Tourism	118

PART 4: ISSUES AND TRENDS IN INSTITUTIONAL DEVELOPMENT

Chapter 12: Public-Private Partnerships in Tourism Clusters	129
Introduction: Stakeholders in Sustainable Mountain Tourism	129
Balance between Public and Private – Competitiveness is Key	140
Chapter 13: Analysis and Assessment Instruments	141
Introduction: Analysis Process and Use of Instruments in Tourism	141
Analysis and Assessment Systems in Tourism	145
Instruments for Analysis and Assessment in Tourism	152

REFERENCES

References	155
-------------------	------------

Foreword

Tourism is the world's biggest industry, and it is still growing. According to the latest published statistics, the industry reached an all-time record in 2004 with 691 million international tourist arrivals worldwide, generating 523 billion US dollars per year. The annual growth rate in tourism is expected to be more than 4% over the next 20 years. The contribution of tourism to developing economies is impressive: tourism accounts for more than twice the amount of cash transfers from rich to poor countries in the form of government aid. The estimated market share for mountain areas is roughly 15-20% of the global tourism market, generating between 70 and 90 billion US dollars per year. Mountains are believed to be second in global popularity as tourist destinations after coastal regions. In spite of its indisputable magnetic pull for tourists, however, the share of the Himalayas in the global tourism market is relatively small. The need to address mountain concerns and the potential contribution that tourism can make to mountain communities are increasingly acknowledged. Agenda 21 of the UN Conference on Environment and Development stated that the fate of the mountains may affect more than half of the world's population and it recognised mountain tourism as an important component in sustainable mountain development and conservation. Remote mountain areas often have great appeal for tourists, and in many of these areas tourism may be one of the few viable options for sustainable mountain development.

The International Centre for Integrated Mountain Development (ICIMOD) began research into mountain tourism in the early 1990s, and gave it priority as a catalyst for development in the Himalayas. The knowledge gathered by ICIMOD over the last 15 years has been packaged into different programmes and training modules to build capacities in mountain tourism. Most of its training manuals are being used as reference materials by tourism organisations, knowledge institutions, policy makers, and development partners in the region, and are cited widely by researchers in mountain tourism throughout the world. Because of their experience in training for mountain tourism, ICIMOD and SNV (Netherlands Development Organisation) were approached by the Asian Development Bank to lead the human resource development component of its South Asian Subregional Economic Cooperation (SASEC) Tourism Development Plan on facilitating sustainable mountain tourism. ICIMOD and SNV, together with the Nepal Tourism Board (NTB), organised a week-long training on mountain tourism for representatives of national and state tourism organisations from Bangladesh, Bhutan, India, and Nepal, with additional participants from the Tibet Autonomous Region of China and Myanmar sponsored by ICIMOD to cover the wider Himalayan region. The importance of the topic and lack of resource materials led to requests to ICIMOD and SNV by trainees to publish the course materials in order to maximise their usefulness. The original course materials have been revised to produce a comprehensive, market-oriented resource document with illustrative case studies from the Himalayan region and are presented here as a Resource Book (Volume 1) and Toolkit (Volume 2).

ICIMOD believes that for tourism to be a vehicle for sustainable poverty reduction in the Himalayas, a pro-poor and inclusive tourism strategy is essential. A facilitation model that enables the participation of all relevant stakeholders will make this possible through participatory tourism approaches and pro-poor partnerships with the private sector supported by sound mountain tourism policy and planning frameworks. I trust that this Resource Book and Toolkit will provide the necessary practical concepts, tools, and approaches to develop a type of mountain tourism that will bring sustainable benefits to the mountain poor and marginalised and to conserve the breathtaking beauty of the Himalayan environment.

Andreas Schild
Director General, ICIMOD

Acknowledgements

Just as the sustainable mountain tourism sector is a multi-faceted phenomenon that can only be a success if it embraces a wide variety of stakeholders, this Resource Book and Toolkit is the result of a collaborative effort of colleagues, partners and resource people who have all contributed their valuable time and inputs to the process.

First, we would like to thank the Asian Development Bank (ADB) for their trust in us to lead the human resource development component of the SASEC Tourism Development Plan on facilitating sustainable mountain tourism. Without their generous financial assistance to design, develop and conduct the initial training course, and to publish the books developed from them, these books would not have been possible. In particular, we would like to acknowledge the dedication and support of Lisa Choegyol (Tourism Resource Consultant), Elizabeth Nanda (Human Resources Consultant), and Snimer K. Sahni (former Senior Project Economist).

Second, we would like to thank the Nepal Tourism Board (NTB) for their assistance in helping us to organise the training course. Their ceaseless efforts in soliciting nominations from the participating countries, sending out invitations to the NTOs from the five SASEC countries (Bangladesh, Bhutan, India, Nepal and Sri Lanka) and helping us with the international logistical arrangements, is very much appreciated. In particular, we would like to praise the support of Lila B. Baniya (Manager Sustainable Tourism Development) and Uday Bhattarai (Assistant Manager Tourism Products and Resources).

Third, we would like to thank the representatives of the national and state tourism organisations of Bangladesh, Bhutan, Myanmar, Nepal, India, and the Tibet Autonomous Region of China who so enthusiastically participated in the training course, and who have persistently underlined the need for more information on the topic and encouraged us to publish the course materials. Their valuable and constructive feedback helped us to fine tune these two books. Many of the country presentations that were made during the training have found their way back into the resource book as illustrative case studies and boxes.

Fourth, we owe much gratitude to our partner organisations who have made a significant contribution by sharing their knowledge and field experiences in planning, developing, and managing (aspects of) sustainable mountain tourism. Many of their experiences have been reproduced in this resource book and toolkit. In particular, we would like to thank the following colleagues and partners: Siddhartha B. Bajracharya from the National Trust for Nature Conservation (former Programme Manager); Uday Bhattarai (Assistant Manager Tourism Products and Resources) and Diwakar Bikram Rana (Manager Tourism Marketing and Promotion) from the Nepal Tourism Board; and Rabi Jung Pandey (former National Programme Manager), Yogi Kayastha (former Monitoring & Evaluation Specialist), Hari Krishna Uprety (former Environment Specialist), and Dechenla Sherpa (former Gender and Communication Specialist) from the Tourism for Rural Poverty Alleviation Programme.

In SNV Netherlands Development Organization, we owe much gratitude to Tej Raj Dahal (Advisor Planning, Monitoring and Evaluation); Nigma Tamrakar (Social Development Advisor), and Jamuna Ulak (Adviser Enterprise Development (Tourism)) for their technical assistance through sharing their insights and experiences on institutional development and organisational strengthening; gender and social inclusion, and value chains and enterprise development in sustainable mountain tourism.

Last, but certainly not least, many colleagues from ICIMOD and SNV have directly or indirectly contributed invaluable professional inputs and time during the training and the preparation of the resource book and toolkit. We would like to thank them all for their support.

Many ICIMOD colleagues were involved in organising and managing the training course that laid the foundation for these two publications. In particular, we would like to thank Xu Jianchu (former Programme Manager Water, Hazards and Environmental Management), for arranging the participation of trainees from the Tibet Autonomous Region of China; Prem Manandhar (Partnership and Planning Officer) for his facilitation of the majority of the training course; Monette Pacia (former Training Support Officer) for her valuable suggestions in designing the original session plan and facilitation of parts of the course; Rajendra Shah (Sr. Programme Assistant Agriculture and Rural Income Diversification) for his administrative support; and Rajen Upreti (Travel and Hospitality Officer) for taking care of the domestic logistical arrangements.

The individual chapters in Volume 1 were prepared by different authors: Farid Ahmad (ICIMOD), Chapter 11; Kamal Banskota (ICIMOD), Chapters 1, 3; Business Council (UNWTO), Chapter 12; Wies Buysrogge, Chapter 7; Tej Raj Dahal (SNV), Chapter 13; John Hummel (SNV), Chapters 1, 2, 7, 9, 11, 12, 13; Ester Kruk (ICIMOD), Chapters 1, 4, 5, 6, 8, 9, 10, 11, 12; Management for Development Foundation (MDF), Chapter 13; Bikash Sharma (ICIMOD), Chapters 4, 5; Dechenla Sherpa (ICIMOD), Chapter 8; Basanta Shrestha (ICIMOD), Chapter 10; Nigma Tamrakar (SNV), Chapter 8; and Jamuna Ulak (SNV), Chapter 9.

The technical inputs from different ICIMOD colleagues have added great value to the two volumes. We highly appreciate the critical comments of Nakul Chettri (Community Biodiversity Specialist) who reviewed the resource book, and Dyutiman Choudhary (Marketing and Enterprise Development Specialist) who reviewed the toolkit. We also appreciate the valuable inputs of Birendra Bajracharya (GIS Specialist), and Lokab Rajbhandari (GIS Analyst) on the role of geographic information systems in mountain tourism. Several ICIMOD staff have devoted time and energy to edit, format, and produce the resource book and toolkit in this final form. The help of the editorial team in the Information, Management, Communications and Outreach Division in this process is highly appreciated, especially the professional inputs of Dharma Ratna Maharjan (Desktop Publisher) for layout and design; Susan Sellars-Shrestha and Greta Rana (Consultant Editors) for detailed editing and providing comments and suggestions; and A. Beatrice Murray (Senior Editor) who coordinated and oversaw the production process.

A number of materials from external sources were consulted and used when preparing the resource book and toolkit. These materials were collected and adapted to mountain tourism specificities to provide mountain-friendly tourism concepts, approaches, and tools. For the chapter on multi stakeholder collaboration in mountain tourism (Chapter 7, Volume I), we owe credit to Wies Buysrogge (freelance consultant), who kindly permitted us to use parts of her earlier unpublished document for SNV and the United Nations World Tourism Organization (UNWTO) on multi-stakeholder tourism approaches in Lao PDR, Nepal, and Vietnam. Likewise, we are grateful for the kind permission of the Business Council of UNWTO to use parts of their publication on Public-Private Sector Cooperation in the Resource Book (Chapter 12, Volume I) and Toolkit (Tool 3, Volume 2). We would also like to give due credit and appreciation to the training manual of the Management for Development Foundation (MDF), which was instrumental in describing relevant analysis and assessment instruments for sustainable mountain tourism planning (Chapter 13, Volume I) and many of the tools in the toolkit. Furthermore, several tools from the toolkit were taken from the Toolkit for Development Workers on Developing Sustainable Communities by SNV Nepal, published by ICIMOD.

Finally, we would like to express our sincere gratitude to J. Gabriel Campbell, former Director General of ICIMOD for his encouragement and support for the training on facilitating sustainable mountain tourism.

Acronyms and Abbreviations

ABTO	Association of Bhutanese Tour Operators
ACA	Annapurna Conservation Area
ADB	Asian Development Bank
APPA	appreciative participatory planning and action
CBO	community-based organisation
CBT	community-based tourism
CO	community organisation
CREST	Centre for Resources and Environmental Studies
DDC	district development committee
DFID	Department of International Development
DNPWC	Department of National Parks and Wildlife Conservation
DoT	Department of Tourism
ESS	enterprise support services
FG	functional group
FIT	free independent traveller
GDP	gross domestic product
GIS	geographic information system
ICIMOD	International Centre for Integrated Mountain Development
IDOS	institutional development and organisational strengthening
INGO	international non-government organisation
IOM	integrated organisation model
IUCN	The World Conservation Union
LFA	logical framework approach
MAD	market analysis and development
MDF	Management for Development Foundation
MDG	Millennium Development Goal
M & E	monitoring and evaluation
MoCTCA	Ministry of Culture, Tourism, and Civil Aviation
MOU	memorandum of understanding
MSE	micro and small enterprise
MSP	multi-stakeholder process
NGO	non-government organisation
NTA	National Tourism Administration
NTB	Nepal Tourism Board
NTNC	National Trust for Nature Conservation
NTO	national tourism organisation
PDR	People's Democratic Republic
PLA	participatory learning and action
PMU	programme management unit
PPST	pro-poor sustainable tourism
PPT	pro-poor tourism
PRA	participatory rural/rapid appraisals
PRSP	Poverty Reduction Strategy Paper
RAAKS	rapid (or relaxed) appraisal of agricultural knowledge systems
SARS	severe acute respiratory syndrome
SASEC	South Asian Subregional Economic Cooperation
SM	social mobilisation

SNV	Netherlands Development Organisation
STDC	sustainable tourism development committee
STDS	sustainable tourism development section
STN	Sustainable Tourism Network
STO	state tourism organisation
SWOT	strengths, weaknesses, opportunities, and threats
TMI	The Mountain Institute
TRPAP	Tourism for Rural Poverty Alleviation Programme
TWG	Tourism Working Group
UNDP	United Nations Development Programme
UNWTO	United Nations World Tourism Organisation
US	United States
USD	US dollar
VDC	village development committee
VICE	visitors, industry, community, and environment

Part 1

Introduction



Participants, trainers, and others in the training programme on Project Facilitation and Management in Sustainable Tourism Development, June 2006

Introducing this Resource Book

This resource book covers

- Participatory sustainable mountain tourism planning and development at regional, national, and state levels
- Resource materials for informed active support for the development, formulation, implementation, management, and monitoring of sustainable mountain tourism development projects at state and national levels
- Tools to improve a variety of skills in project formulation, implementation, management, and monitoring of sustainable mountain tourism development projects

Introduction and Background of the Resource Book

The Himal Alaya – the Abode of Snow – has, for a long time, caught the imagination of travellers. The mountain range, commonly known as the Himalayas, is characterised by immense natural beauty and is inhabited by over 150 million people who have an unmatched rich cultural diversity. It is also one of the poorest regions in the world. Many mountain dwellers are dependent on subsistence agriculture and, faced with a booming population and a rapidly deteriorating natural environment, the call for alternative and sustainable livelihood options has become the need of the day. Studies have shown that tourism is one of the more promising alternative livelihood options for people in the Himalayas (Sharma 2000a; East et al. 1988; Kruk and Banskota, in preparation). With its unique natural and cultural resources, the Himalayan region has indisputable tourist potential, and the demand for mountain tourism is growing rapidly. Mountain tourism provides opportunities for, as well as challenges to, providing gainful employment, income, and other socioeconomic benefits, while at the same time conserving the rich natural and sociocultural heritage of the region. Various tourism development projects and plans have been formulated, developed, and implemented in different parts of the Himalayas to promote sustainable mountain tourism – some on a state and national scale, others set up as (sub) regional collaboration projects.

One of these subregional initiatives is the South Asian Subregional Economic Cooperation (SASEC) Tourism Development Plan. Commissioned by the SASEC Tourism Working Group (TWG) for the initial four SASEC member countries of Bangladesh, Bhutan, India, and Nepal (later joined by Sri Lanka in 2005), this plan builds upon the existing tourism plans of these four attractive but utterly different Himalayan countries. The TWG agreed that the plan should be a thematic framework based on common themes for future tourism development. The plan proposes core strategic directions for the TWG that build upon and add value to the national mountain tourism agendas of the SASEC countries. One of the components of the plan is a human resource development component to train national tourism organisations (NTOs) and state tourism organisations (STOs) on project facilitation and management in sustainable mountain tourism development, in order to increase their skills in facilitating sustainable mountain tourism projects in the region and boost their confidence in participating in subregional tourism cooperation projects.

At the request and with the support of the Asian Development Bank (ADB), the International Centre for Integrated Mountain Development (ICIMOD), SNV Netherlands Development Organisation, and Nepal Tourism Board (NTB), developed and organised a training programme on facilitating sustainable tourism projects from June 12 to 17, 2006, at the ICIMOD Headquarters in Kathmandu, Nepal. Bangladesh, Bhutan, India, and Nepal selected five representatives each to attend this training. Additional trainees from Tibet/China and Myanmar were sponsored by ICIMOD in order to increase the benefits of the training in the wider Himalayan region.

Given the success of the training course, as assessed by internal and external evaluations, and the clearly voiced need of participants to receive more theoretical and practical reference materials on the subject, ICIMOD and SNV were requested to transform the original course materials into comprehensive reference material. This request was endorsed by ADB, and with financial support from ADB and technical input from the NTB and other partners like the Tourism for Rural Poverty Alleviation Programme (TRPAP), and the National Trust for Nature Conservation (NTNC), ICIMOD and SNV reworked the initial course materials into a separate but interlinked Resource Book (Volume 1) and Toolkit (Volume 2).

Based on the course evaluation results, as well as on wider assessments of information needs, some of the course contents were adapted to become more suitable to the industry's needs. Some subjects originally covered in the training programme have been omitted altogether (such as proposal writing), and some new subjects have been added or expanded upon (such as enterprise development for sustainable mountain tourism, market linkages, and partnerships in sustainable mountain tourism clusters). The reason for doing so was to produce a market-compatible and more complete knowledge database that transcends its original use as a mere source of further reference for the original trainees, and which reaches out to a wider network of professionals and practitioners with an interest in the subject.

Guiding Principle of the Resource Book

NTOs and STOs are involved in planning and developing sustainable mountain tourism in their countries and states. Policies and plans (like the government's five-year plans) are drafted, and sustainable mountain tourism projects are developed and implemented on different scales and by different stakeholders. What are sustainable mountain tourism projects, and how can they be planned and managed? What is the role of the country or state in coordinating and facilitating this process? And how can all the stakeholders work together effectively? This Resource Book strengthens the capacities of NTOs and STOs and/or other facilitators to support a process of planning for sustainable mountain tourism development and plan-based project facilitation in their respective countries or states.

It is assumed that NTOs and STOs are often involved more in supporting planning processes for sustainable mountain tourism (for instance in providing for long-term national tourism development plans) and tourism project formulation and monitoring, rather than implementing the tourism projects themselves. As tourism is the fastest growing industry in the world and becoming more and more competitive, there is an urgent need for proper planning and management of the industry, while ensuring benefits accrue to local mountain communities and conservation of the rich (though fragile) natural and cultural resources. The focal question in this Resource Book is, therefore, how to facilitate a process from sustainable tourism planning to project formulation and monitoring back to the next tourism planning cycle.

NTOs and STOs facilitate projects in project cycles: they initiate and support project formulation in the 'analysis' phase; they support project implementation and monitoring in the 'action' phase; and they evaluate project results (directly or through other organisations) during the 'assessment' phase. These evaluations in turn support national and regional policies and plans and form the base of a new cycle of project formulation (analysis), implementation and monitoring (action), and evaluation (assessment). This process is graphically depicted in Figure 1.1.

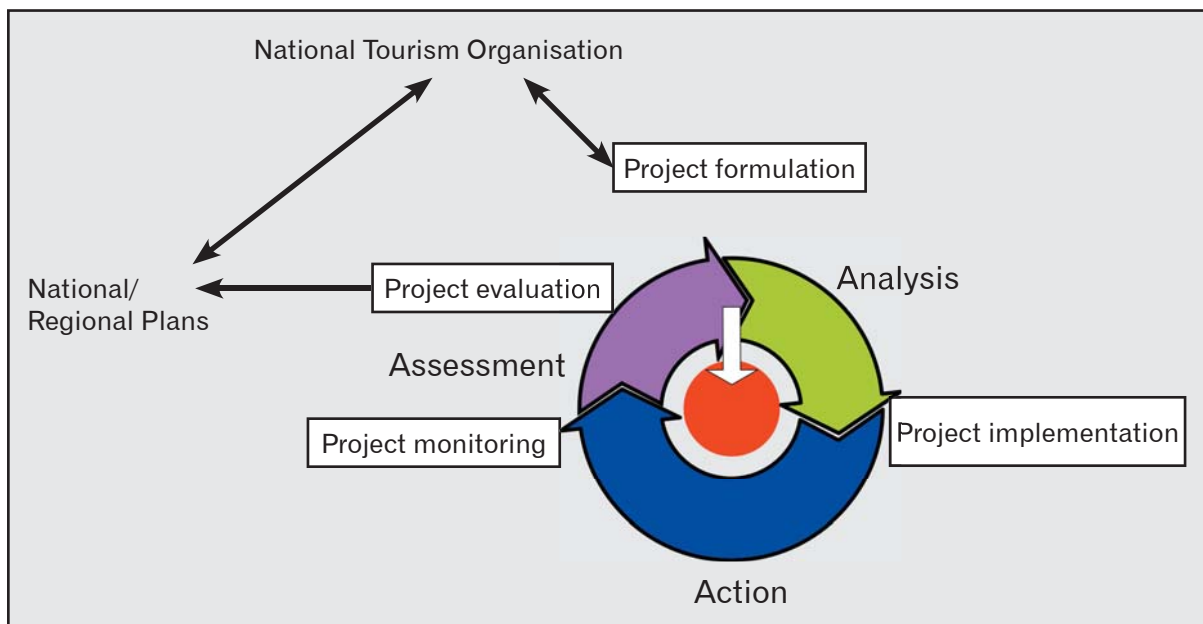

Figure 1.1: Facilitation of the project cycle

In this Resource Book, facilitation of the project cycle is introduced as a guiding principle and ordering process for tools in sustainable mountain tourism planning and development – emphasising poverty reduction, gender, and social inclusion, and the sustainable use of natural and cultural resources – and the planning and management of activities in tourism organisations like NTOs and STOs.

Resource Book Flow

The Resource Book flow is based on the understanding of sustainable mountain tourism planning and the role of different stakeholders in the implementation of these plans through projects. The role of facilitators like NTOs and STOs is highlighted in this process, and tools to support the guidance of the process are introduced.

The Resource Book first introduces recent concepts in sustainable mountain tourism development. It then introduces the framework in which all NTOs and STOs have to work – regional and national plans, national policies, and laws. Then the Resource Book introduces tourism planning and management to develop tourism in a more sustainable, pro-poor, inclusive, and participatory way. Together the combination of these plans, policies, and laws and the participatory planning process form the context in which the NTOs and STOs function.

Thereafter NTOs and STOs are placed more in the centre stage of sustainable mountain tourism development activities. Approaches and tools are introduced through which NTOs and STOs can support tourism development activities, so that NTOs and STOs can scan the context in which projects are formulated and implemented, and determine who are or need to be involved. Finally, project formulation, implementation, and monitoring and evaluation are explained and facilitation tools discussed.

Regional and Mountain Perspective

Throughout this Resource Book, the term ‘sustainable mountain tourism’ is used to describe approaches and practices that take full account of current and future economic, social, and environmental impacts, while addressing the needs of visitors, the tourism industry, the environment, and host communities, especially the poor and other socially disadvantaged groups such as women and minority mountain people. As such, the concept of sustainable mountain tourism is based on pro-poor, pro-local, pro-women, pro-social, pro-environment, and pro-culture inclusion, as well as

other sustainability principles. It equals concepts that elsewhere may be referred to as pro-poor tourism, community-based or small-scale tourism, ecotourism, green tourism, alternative tourism, or responsible tourism, insofar as they rest on the same principles.

‘Mountain tourism’ is not a specific type of tourism. It refers to any tourism activity taking place in mountain areas in a sustainable way and includes all tourism activities for which mountains are seen to have a comparative advantage such as trekking, mountaineering, white water rafting, cultural tourism, and pilgrimages. The need to address mountain concerns and the potential contribution that tourism can make to mountain communities was recognised at the United Nations Conference on Environment and Development in 1992. Since then, the term ‘mountain tourism’ has been taken up and developed by ICIMOD and other partners in the Himalayan region. Taking place in regions that are remote, difficult to access, and characterised by a rich natural and cultural diversity, wilderness, and often a subsistence way of life, mountain tourism has its specific issues and characteristics. This ‘mountain perspective’ is an integral part of this Resource Book and is emphasised and illustrated in case studies and examples from the region (Bangladesh, Bhutan, China/Tibet, India, Myanmar, Nepal, and Sri Lanka) which highlight practices and issues in sustainable mountain tourism from a regional perspective.

Structure and Overview of the Resource Book

This resource consists of two separate but interlinked volumes. Volume I – the Resource Book – deals with all aspects of the project cycle (project cycle planning, implementation, management, and monitoring of sustainable mountain tourism development) from a theoretical and practical perspective. Volume 2 – the Toolkit – gives an overview of all the tools that can be used within these different stages of the project cycle. The chapters and tools in both volumes are organised in a chronological sequence that follows their stage in the project cycle.

Volume I is organised into four parts: Introduction, Overview of Concepts, Overview of Approaches, and Issues and Trends in Institutional Development. Chapter 1 introduces the structure and general context of the Resource Book. In Chapter 2 the central and overarching theme of the Resource Book – project facilitation and management in sustainable mountain tourism development – is explained in more detail. This is followed by a conceptual part (Part 2) in which an overview is given of the tourism industry (Chapter 3), concepts and principles of sustainable mountain tourism (Chapter 4), and sustainable mountain tourism planning and development (Chapter 5). In Part 3, emerging approaches and cross-cutting issues in contemporary sustainable mountain tourism are discussed such as participatory planning and organisation (Chapter 6), multi-stakeholder issues (Chapter 7), gender and social inclusion (Chapter 8), tourism enterprise development (Chapter 9), the use of geographic information systems (GIS) (Chapter 10), and monitoring and evaluation in tourism (Chapter 11). Part 4 (Chapters 12 and 13) concludes with a discussion of the most important issues relating to institutional development, focusing on the specific role of NTOs and STOs and discussing the most important analysis and assessment instruments for sustainable mountain tourism planning and development. The tools for use within these different conceptual frameworks and approaches are described in detail in Volume 2.

Intended Use of the Resource Book

This Resource Book is designed as a reference book. Although the training programme on which it is based was initially designed for state and national tourism organisations, it is intended for wider use. Its broad perspective, covering all stages of the project cycle, and its inclusion of practical tools for use in this cycle, will make it of interest to tourism professionals working at all levels, including those working in tourism planning and development, implementers of sustainable mountain tourism projects, monitoring and evaluation officers, policy makers, and people working in mountain development. The Resource Book may also be a useful source of reference for those studying or working in tourism training institutes or tourism management schools, as well as in academia.

Chapter 2

Project Cycle Facilitation

This chapter covers

- Project cycle management and the difference between implementation and facilitation in sustainable mountain tourism
- The Triple-A (analysis, action, and assessment) model for sustainable mountain tourism
- Mountain tourism project cycles at strategic, organisational, and project levels

Introduction: Project Cycle Facilitation in Sustainable Mountain Tourism

This Resource Book supports NTOs and STOs to facilitate sustainable mountain tourism on three development levels.

1. Strategy level
2. Institutional or organisational level
3. Project level

Project cycle facilitation is used as an approach to address these three levels of facilitation. This chapter provides a framework for NTOs and STOs to facilitate tourism development processes at the strategic, institutional or organisational, and project levels (see Figure 2.1).

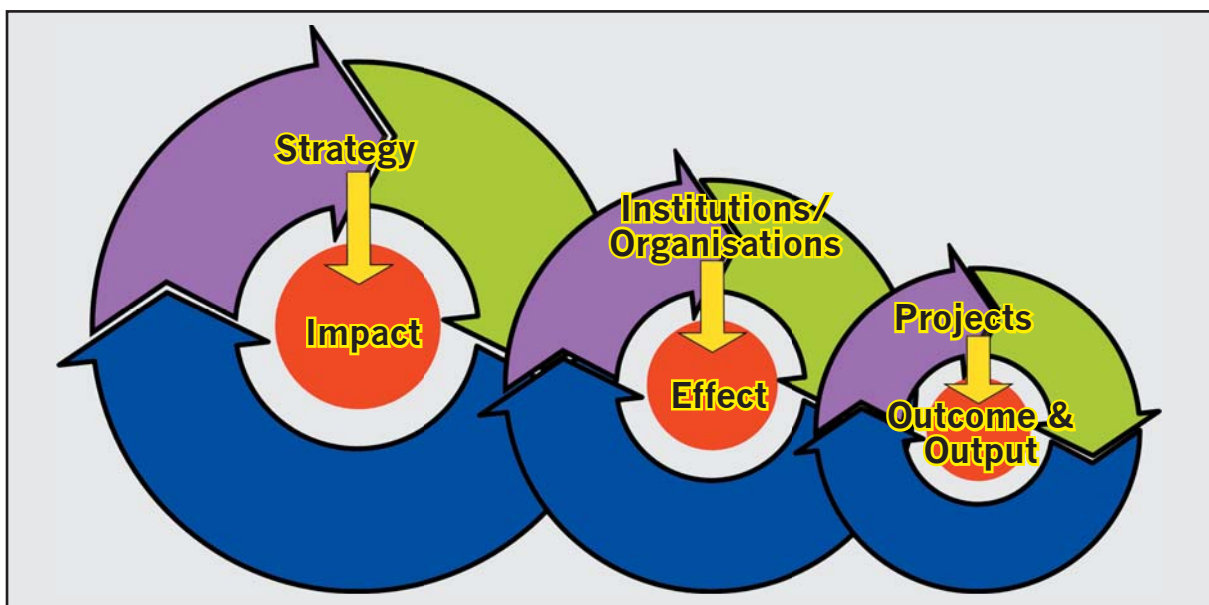

Figure 2.1: Project cycle facilitation at three levels

- **Strategy cycle** => results in **impact**
- **Institution** or **organisation** or **NTO cycle** => results in **effect**
- **Project cycle** => results in **outcome** and **output**

The three cycles (strategy cycle, institution or organisation cycle, and project cycle) are all elements of the involvement of NTOs and STOs in the development of sustainable mountain tourism. In this chapter these three cycles are explained.

A Framework for Tourism Project Cycle Facilitation

Facilitation versus implementation

By their very nature, NTOs and STOs are coordinating organisations. They provide policies and frameworks, they bring stakeholders together, and they support tourism development processes. More often than not, they facilitate these processes rather than implement them themselves. The case of the Netherlands Development Organisation (SNV) is used to illustrate the shift from being an implementing organisation (as SNV was until the end of the 1990s) to a facilitating and capacity-building organisation (as it is today), to exemplify an approach towards project facilitation (see Box 2.1).

There are several facilitation skills that can be used to facilitate sustainable mountain tourism development processes at a strategic, institutional or organisational, or project level:

- **Team commitment:** effective collaboration, good atmosphere, results orientation, openness
- **Steering and progress control:** efficient planning and organisation of complex activities
- **Focus on quality:** intention to develop others in order to function better
- **Innovation:** new ideas, solutions, and applications, as well as drive for continuous improvement of concepts, knowledge, and services
- **Relationship networks:** good contacts that are relevant to the realisation of the intended result
- **Impact:** influence, make a difference and convince
- **Expertise:** insights and skills in a knowledge area, information dissemination
- **Focus on partner needs:** intention to assist partners in achieving their goals and increasing their capacities

Three steps in the tourism project cycle: the Triple-A Model

There are three cyclic steps that should be present at all three levels of the project cycle, (strategy, institution or organisation, and project level) also called the 'AAA' or 'Triple-A' Model. The objective of the Triple-A Model is to identify the different steps within the three levels using standard formats for procedures, key documents, guidelines, and quality standards. In addition, the Triple-A Model provides a framework for allocating roles and responsibilities for key decisions in any tourism development process.

As any model, this model is a simplification of reality and can be useful as a sort of checklist. Even if the steps cannot be followed in sequential order, each step should have a story. It is imperative to be able to explain the courses of action undertaken, what the actions were about, and what results were achieved. A graphical representation of this model is depicted in Figure 2.2.

Box 2.1: SNV: From Implementation to Facilitation

1. From Poverty alleviation to the struggle against poverty

Poverty is more than just a percentage of people living on less than a dollar a day. SNV has experienced that helping small groups of poor people to earn and eat and drink more doesn't fundamentally change the structural causes of their poverty. SNV has learned that poverty exists because society and its institutions fail to correct excessive socio-political and economic inequalities and inequity, leading to injustice and exploitation. Meso-level organisations in developing countries have the position and the potential to influence such causes of poverty at the meso level and to act and inspire others to act.

2. From joint interventions to local responsibility

In the 1990s it was recognised that development cannot be brought about by external parties, but should be owned, guided, and led by committed local parties. Key notions are ownership and local responsibility. Increased capacity of local actors is essential to combat poverty effectively and in a sustainable way. SNV sees its relations with local organisations as ones in which SNV supports them in developing their capacities, doing their work, and realising their goals. Local organisations have direct responsibility; and they call the shots. They own and lead change processes. Their needs and priorities take centre stage. SNV's role is one of serving, challenging, advising, supporting, and, where necessary and at their request, SNV can influence and lobby on their behalf.

3. From project management to process facilitation

Development is a highly complex process, with physical, technical, economic, social, and political dimensions and with many stakeholders. The dynamics of development processes are, therefore, only partly predictable and manageable. SNV has experienced this – often the hard way. Project concepts and management instruments were developed originally for relatively well-controlled processes. A variety of more dynamic and flexible concepts of process facilitation for understanding and managing complex change has become available over the last 10 years.

4. From SNV programmes to client-driven activities

The shift from SNV as a manager of large development programmes with their own development objectives to a provider of demand-oriented, capacity-strengthening services entailed a profound review of the way in which SNV managed its interventions. Transparency in the process of demand formulation and negotiation is essential. Local organisations state their interests, expectations, and the intended results of the cooperation in a service contract in which the local organisation is the principal. Portfolios of such partner-driven activities form the new structuring elements through which SNV organises its advisory practice.

5. From implementers to change facilitators

The above-mentioned shifts have consequences for the role that SNV experts play. They are no longer required to achieve results in poverty reduction directly. Instead they are required to strengthen the capacities of local organisations to achieve results. As the changes aspired to are often complex, there is a special emphasis on support in change processes, rather than punctual advice on specific matters.

6. From isolated knowledge transfer to facilitation of knowledge exchange and development

Nowadays information is available from many sources. Arriving at solutions to complex issues requires relevant information from different corners and the ability to transform it into new applicable knowledge that addresses the specific situation. SNV advisors are no longer prescribing experts who transfer their knowledge, but facilitators of networks of knowledge exchange, enrichment, and development that are able to meet local needs.

Source: Adapted from SNV 2002

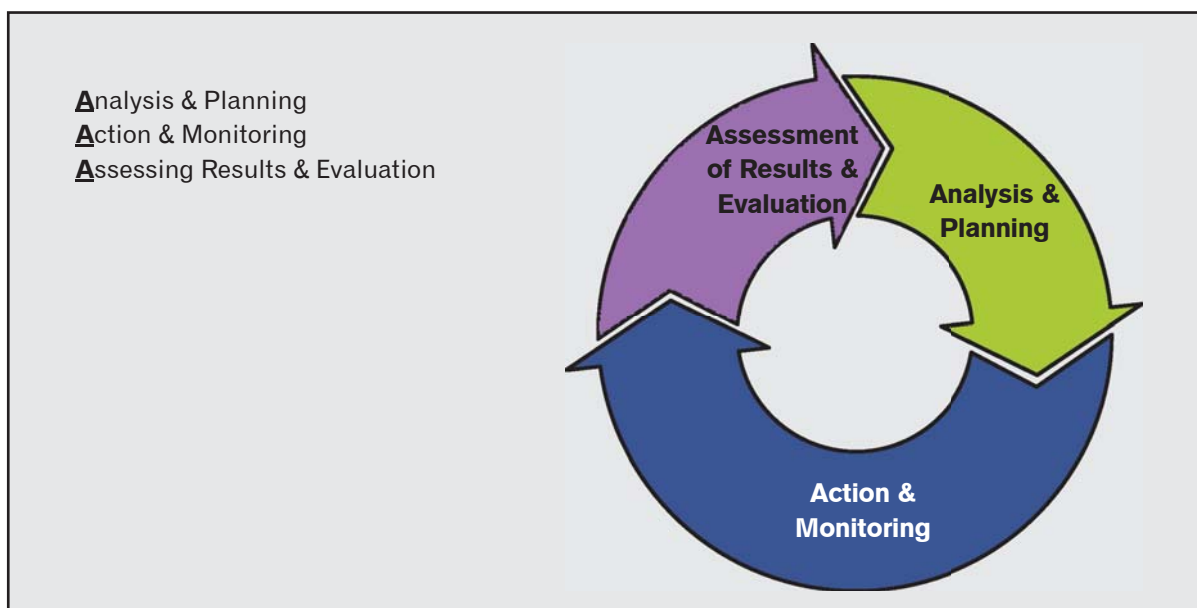

Figure 2.2: The Triple-A Model

This Resource Book explains how to conduct **A**nalysis, how to engage in **A**ction, and how to **A**ssess results on the three levels as shown below.

Triple-A on the Three Levels				
	Results to be achieved at this level	Process Steps		
		Analysis	Action	Assessment
Strategy Level	Impact (=improvements in the lives of the poor)	Strategic planning; contextual analysis (see Volume 2, Tools 32 and 5)	Implementing strategies and managing	Multi-stakeholder impact analysis
Institutional/ Organisational Level	Effect (=enhanced performance)	Organisational assessment	Capacity strengthening at NTO level	Effect assessment
Project Level	Outcome (=enhanced capacity) Outputs (services delivered)	Contracting (issue analysis and activity planning)	Implementing a project	Measuring the result of outputs and outcomes

Triple-A in the tourism strategic cycle

It is important to analyse where, and with whom, to work in order to achieve the most effective impact on poverty reduction through tourism. This requires substantial knowledge about the tourism context and the stakeholders in order to make proper strategic decisions regarding thematic and geographic scope. It needs to be defined how problems and opportunities can be identified; who the key stakeholders are that can bring change; how to ensure gender mainstreaming and social inclusion in tourism; and how to link tourism targets to the national poverty reduction strategies and to the Millennium Development Goals (MDGs).

The result of these considerations is a strategy document that guides choices for NTOs and STOs on what support to offer in the tourism development process and how to identify clients, partners, and sponsors; and which establishes realistic tourism targets.

Impacts are not achieved by one organisation working alone, but often emerge through the work of many actors and multiple factors. Therefore, measuring impact cannot be linked to a single organisation. It is recommended that a multi-stakeholder impact analysis be carried out to determine what changes have occurred and how the various actors and factors have contributed to this. Lessons derived from these impact analyses will feed into the positioning phase of the next tourism strategy cycle (see Figure 2.3).

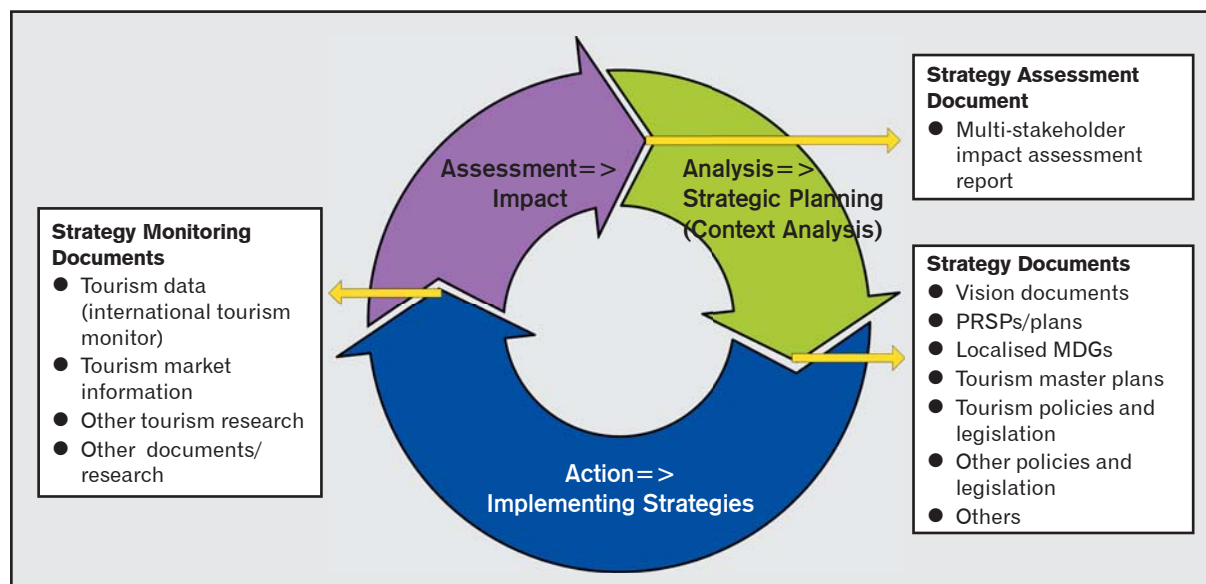

Figure 2.3: The strategic cycle

The first step in the tourism strategy cycle is **analysis** (strategic planning). The strategic planning exercise consists of a multi-stakeholder contextual analysis of problems, opportunities, stakeholders, issues at stake, and targets at the impact level (see Volume 2, Tool 5). This step results in strategic plans in which tourism targets are set in alignment with national tourism strategies. This should result in strategic plans being produced, for instance every three years (see Volume 2, Tool 32).

The second step is **action** (implementing strategies). Implementing and reviewing strategies consists of monitoring and checking the progress of strategic plans; evaluating their success and challenges; and regular adjustment of the strategy whenever necessary. This step should result in the projected impacts outlined in the strategic plan.

The third step is **assessment** (multi-stakeholder impact assessment). Impact assessments are always conducted by external consultants to maintain impartiality at the evaluation level. Partnering with other organisations improves the reliability of analysis results, as true tourism development emerges through the work of many actors and factors.

The tourism strategy cycle is concluded with an evaluation meant to provide insight into the impacts achieved (result measurement) and how the various actors and factors have made contributions. Lessons derived from these impact analyses will feed into the analysis and planning phase of the next tourism strategy cycle.

Contextual analysis (see Volume 2, Tool 5), predicting project trends, setting goals and objectives, identifying alternatives, and developing a strategy to reach the set goals is all part of the analysis (Strategic Planning; see Volume 2, Tool 32). The implementation of the plan is the action, and evaluating, reflecting on, and reviewing the whole cycle form the assessment. In all stages of the cycle tourism stakeholders are involved (see Figure 2.4). An example of a tourism strategy cycle is given in Box 2.2, showcasing this generic planning process in a localised context.

Box 2.2: Tourism Strategy Cycle from the Tourism for Rural Poverty Alleviation Programme in Nepal

In the TRPAP programme, participatory district tourism plans were developed using a tourism strategy cycle process. TRPAP staff and staff of the Nepal Tourism Board (NTB), as well as consultants and local authorities, were all involved in the district tourism planning process. The analysis phase included the development of terms of reference, desk studies, field work, workshops and meetings, and drafting and validating the plan. In the action phase the plan was implemented locally by stakeholders with support from TRPAP and the NTB. The assessment phase was also done locally, with support from TRPAP and NTB. The whole process is illustrated graphically below.

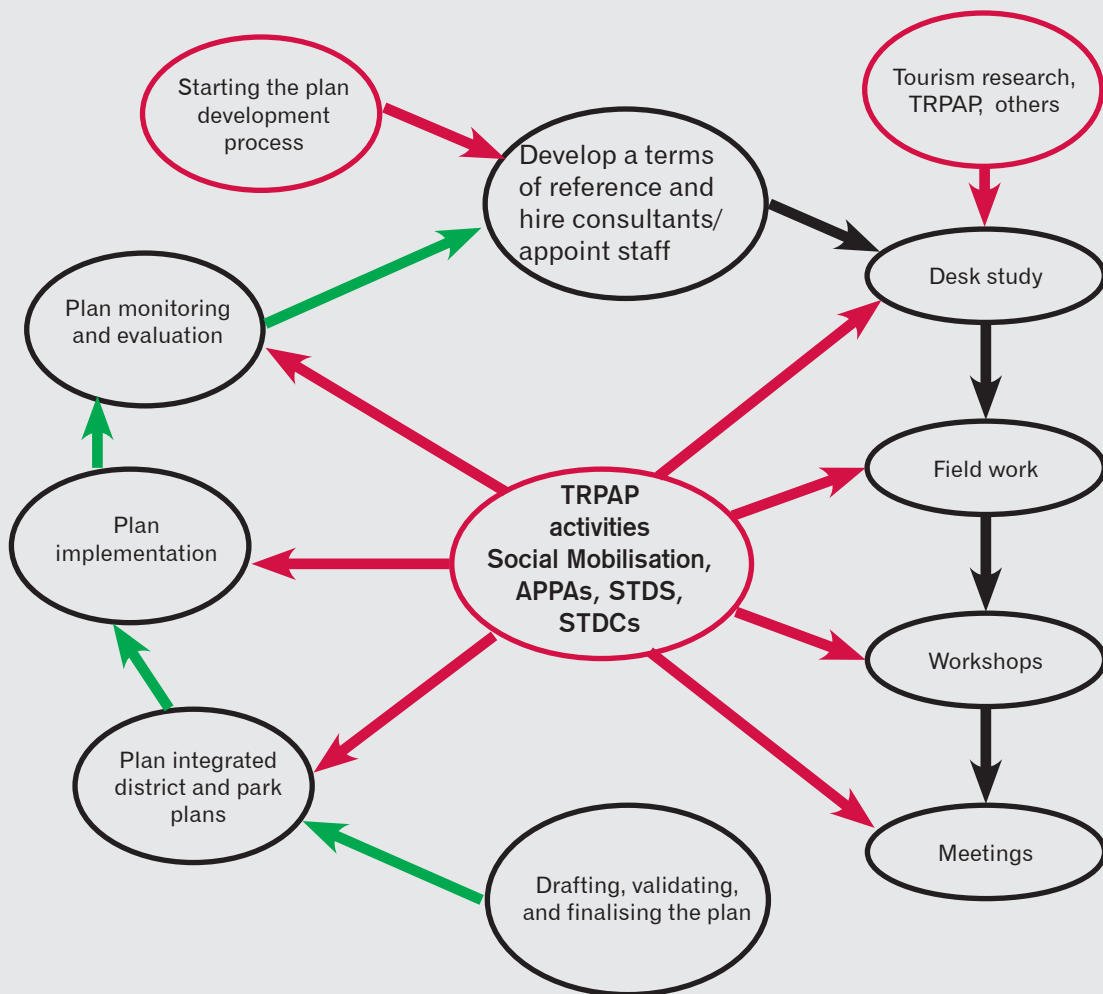

Red arrows indicate support from TRPAP/NTB
Black arrows indicate the taskforce/consultants' team
Green arrows indicate local implementation by district and park authorities

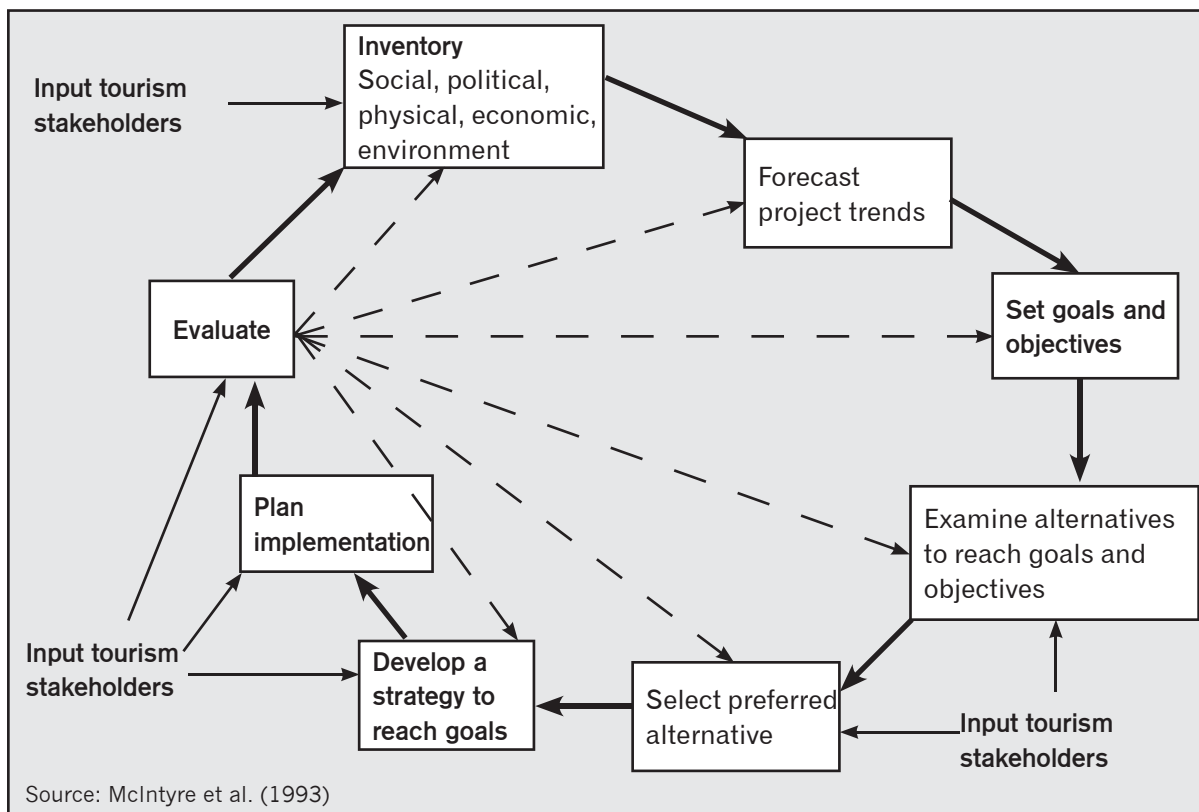

Figure 2.4: Example of a tourism strategy cycle

Triple-A in the institutional or organisational cycle

Similar cycles can be developed at the institutional or organisational level (also called the NTO level). Firstly, institutional and organisational analysis is conducted (instruments and tools for this are introduced in more detail in Chapter 13). Several documents are included in the analysis phase, including the NTO business plan, tourism planning documents, marketing strategies and plans, and the NTO capacity development plan. Action is centred on the facilitation of tourism development projects, implemented through a range of stakeholders, and capacity development of the organisation itself. Monitoring is conducted as part of action; the organisation's annual reports are important monitoring documents. During assessment, tourism projects and capacity development are reviewed together with relevant documents. A graphical summary of the different steps and phases is provided in Figure 2.5.

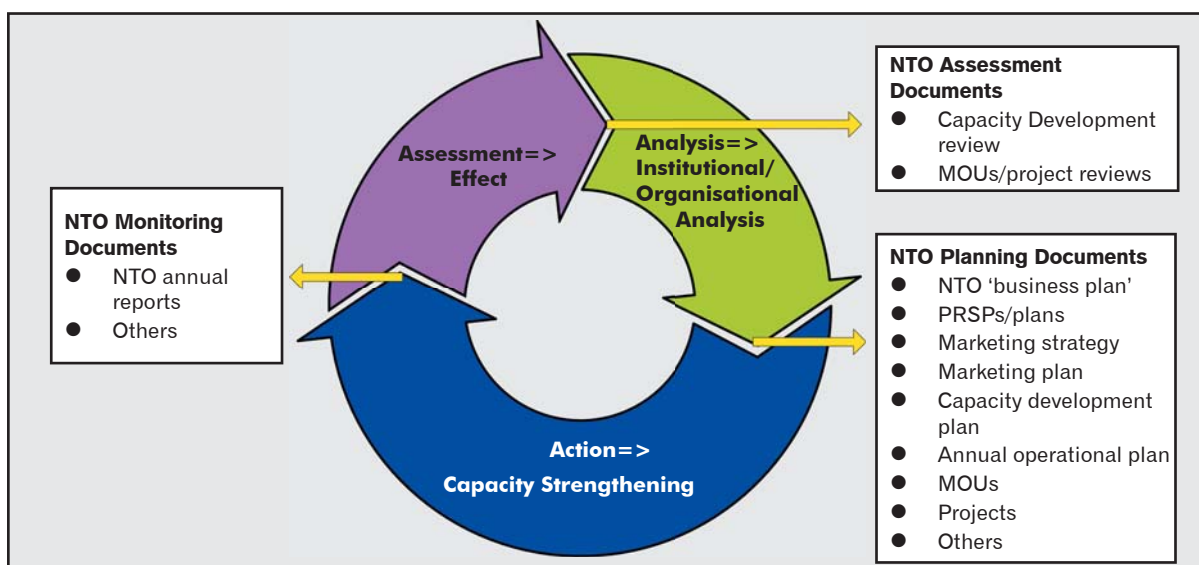

Figure 2.5: Triple-A in the institutional or organisational cycle

Triple-A in the tourism project cycle

The tourism project cycle includes an analysis of the issues and activities in the project. Action is the implementation and monitoring of the tourism project and assessment is where the tourism project is reviewed. This relationship is illustrated graphically in Figure 2.6.

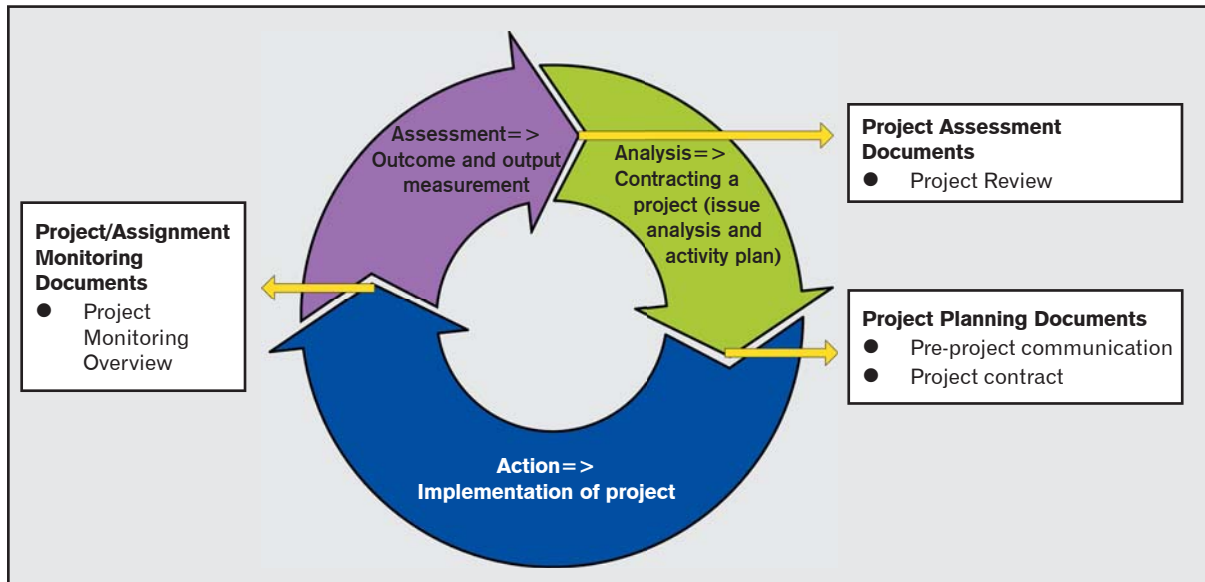

Figure 2.6: Triple-A in the tourism project cycle

Planning cycles are introduced even within tourism project activities. A good example is the appreciative participatory planning and action (APPA) process used in several projects in Bhutan, China/Tibet, India, and Nepal to involve local communities in planning mountain tourism activities in their villages. Figure 2.7 summarises the main steps of this popular participatory cycle. More details about this approach and how it is linked to the tourism project cycle and facilitation process are given in Chapter 6.

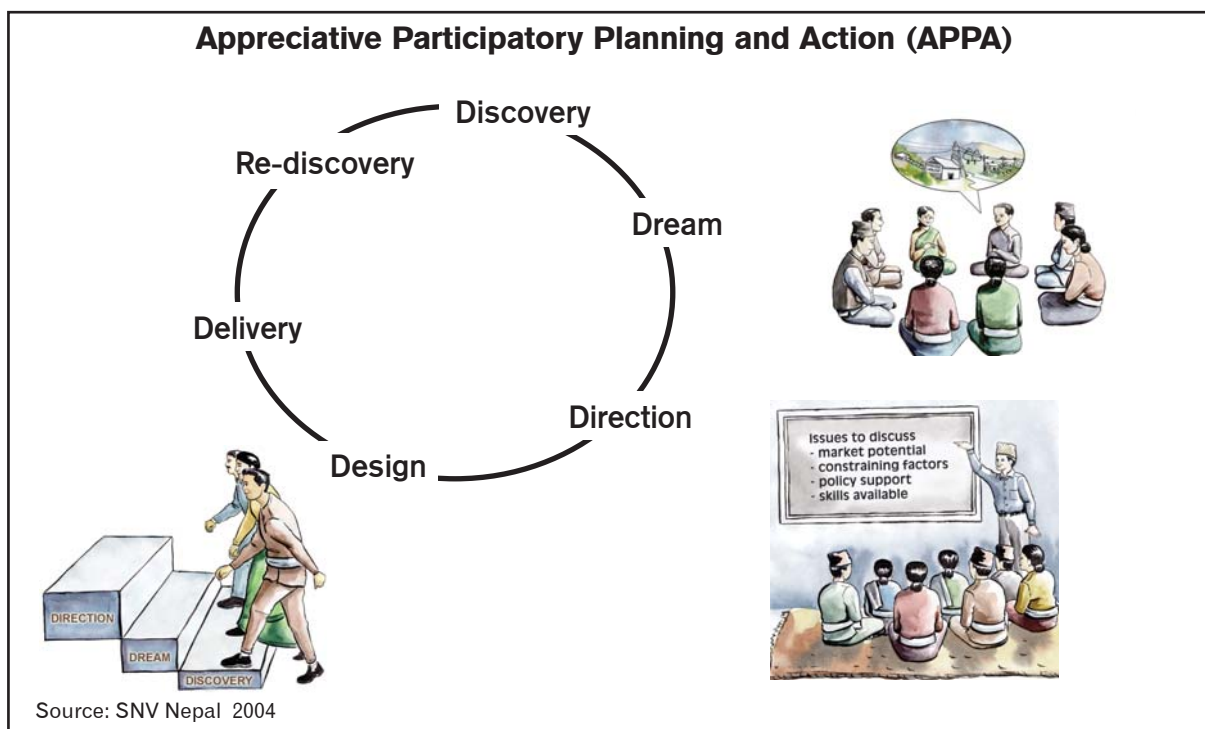

Figure 2.7: The APPA cycle

In order to make the cycles more 'lively' participatory positioning exercises can be conducted. Box 2.3 shows an example of a participatory positioning exercise.

Box 2.3: Participatory Positioning Exercise

A small exercise can be conducted to determine which of the three cycles tourism professionals are involved in during their daily work. For this exercise a poster of the three cycles is needed and some Post-it notes. Request all professionals to have a look at the three cycles on the poster and ask them two questions:

1. Where do you work most in these three levels of project cycle facilitation? At the strategic level, at the institutional or organisational (NTO/STO) level, or at the project level?
2. Are you involved in the analysis, action, or assessment stage of the cycle?



All professionals can stick a Post-it note with their name and designation on the poster at the relevant place on the three cycles. Then the trainer can emphasise those sessions in which most of the professionals are working.

For instance, in the training course that was conducted in June 2006 in Nepal (see picture above); participants were more involved in the assessment of the strategy cycle, assessment of the organisational cycle, and in the analysis, action, and assessment of project implementation. Specific emphasis was given to these aspects in the training course.

Part 2

Overview of Concepts

Chapter 3

Overview of Tourism

This chapter covers

- Concepts, definitions, and types of mountain tourism
- Trends in international tourism, the role of mountains in tourism, and the impacts and some major issues and constraints in sustainable mountain tourism

Introduction: Concepts and Definitions of Tourism

All tourism includes some travel but not all travel is tourism. The characteristics of tourists and their behaviour provide the basis for the conceptualisation of tourism. It is important to classify tourists into different categories, as each type of tourist has a different impact which can be either positive or negative (or both). Adequate understanding of the impacts generated by different types of tourism is essential for formulating policies that benefit a country, the communities visited by the tourists, and the environment. Some of the characteristics of tourism are as follows.

- Tourism arises from the movement of people to, and their stay in, various destinations.
- The journey to, and stay in, the destination includes activities at the destination.
- The journey and stay take place outside the normal place of residence and work; hence, tourism gives rise to activities that are distinct from those of the resident and working populations of the places through which tourists travel and in which they stay.
- The movement to destinations is temporary and short-term in character, with the intention to return within a few days, weeks, or months.
- Destinations are visited for purposes other than taking up permanent residence or employment remunerated from within the places visited. Hence, the purpose of the visit is also an important characteristic of tourism.

The United Nations World Tourism Organisation (UNWTO)'s definition of a tourist is: "a person travelling outside his or her usual environment for a specified period of time with a purpose of travel that is other than an activity remunerated from the place visited."

This definition has several issues related to space, time and duration, and activity.

- 'Usual environment' is intended to exclude trips within the areas of usual residence and also frequent and regular trips between the domicile and the workplace and other community trips of a routine character.
- 'A specified period of time' is intended to exclude long-term migration.
- 'An activity remunerated from the place visited' is intended to exclude migration for temporary work only.

Tourists have different types of impacts on the areas they visit (e.g., income and employment, cultural, and environmental). Governments may have different regulations for each group, and this has implications for the local economy. Clearly, how the various terms are defined is crucial to the measurement of tourism demand and for international comparison. In order to improve the collection of statistics and understanding of tourism, it is essential to differentiate between the various types of visitors. Some of the following categories are useful.

- **International tourist** – A visitor who travels to a country other than that in which he or she is usually resident for at least one night, but not more than one year, and whose main purpose of visit is other than the exercise of an activity remunerated from within the country visited.
- **International excursionist** – A visitor who travels the same day to a country other than that in which he or she has his or her usual residency for less than 24 hours without spending the night in the country visited and whose main purpose of visit is other than the exercise of an activity remunerated from within the country visited (e.g., a cruise ship visitor).
- **Domestic tourist** – A tourist who travels internally within his or her own country for not more than six months.

For analytical purposes tourism has also been classified into different categories, such as:

- Event tourism and gastronomic tourism (world cup football, cuisine)
- Health and recreational tourism (traditional healing, sightseeing)
- Children’s and youth tourism
- Individual tourism
- Business tourism
- Nature-based or ecotourism (wildlife viewing, fishing, birdwatching)
- Adventure tourism (skiing, white water rafting, mountaineering)
- Pro-poor tourism
- Community-based tourism (homestays, cultural programmes)
- Heritage tourism (archaeological sites, cultural heritage)
- Pilgrimage tourism (monasteries, temples, sacred sites)

As explained in the introduction to this Resource Book, the term mountain tourism refers to any tourism activity that takes place in mountain areas in a sustainable way and includes all tourism activities for which mountains manifest a comparative advantage such as trekking, mountaineering, white water rafting, cultural tourism, and pilgrimages. In the Himalayan region, the most important forms of mountain tourism may be grouped into three types; namely, FITs (free independent travellers), group tourists (organised groups), and mountaineers. While the first two groups come to enjoy the rich environmental and cultural resources that abound in the Himalayas, the third group is primarily interested in climbing Himalayan peaks. The three types of mountain tourists are defined below.

- **FITs** – FITs can be defined as ‘free independent travellers’ who carry their own backpacks or hire a guide or porter to assist them and who eat and sleep in local mountain lodges or ‘tea houses’ (or tents).
- **Group tourists** – This category consists of tourists who come on a scheduled trip or join up with friends for a customised, self-contained trek, organised by an overseas’ adventure travel company or with a local trekking agency. The full service includes all camp services and equipment such as sleeping bags, dining and toilet tents, cooking gear, meals, guides, cooks, and porters.
- **Mountaineers** – Mountaineers are special types of tourists who visit the Himalayas to climb peaks. This type of tourism requires considerable skill and is generally very expensive.

Tourism: Dynamism and Growth

The substantial growth in tourism activities clearly marks tourism as one of the most remarkable economic and social phenomena of the past century. Tourism is the fastest growing industry in the world. The number of international arrivals has increased worldwide from a mere 25 million in 1950 to an estimated 760 million in 2004, corresponding to an average annual growth rate of 6.5 per cent. Box 3.1 gives an indication of how this quantitative growth links to broader qualitative tourism trends.

Box 3.1: International Travel no Longer a 'Luxury' but a Right

One of the key conclusions of a recent study on the main drivers that affect consumers in key travel markets, and that will shape the future of the global travel industry in 2020, is that international travel is no longer seen as a luxury. Instead it is considered a 'right' by today's increasingly affluent society, and holidays are becoming increasingly accessible to lower income families. Recent research (Eurobarometer/16,000 respondents aged 15+) shows that when asked to consider lifestyle factors that are perceived to be 'absolutely necessary to live properly today' 84 per cent stated 'sufficient leisure time and means to enjoy it'. In 1990, when asked the same question, only 40 per cent viewed this factor as important.

Source: Cendant 2005

In 2004, the 760 million international arrivals generated a total of US \$622 billion in receipts worldwide. Predicted growth rates remain high and, although patterns have fluctuated from year to year (most recently due to terrorism, severe acute respiratory syndrome (SARS) and bird flu, and natural disasters) tourism has shown a strong and rapid ability to recover.

The United Nations World Tourism Organisation (UNWTO) is predicting that international arrivals will more than double to over 1,500 million by 2020. In terms of regional growth, the strongest relative growth is expected to occur in developing countries. The contribution of tourism to developing economies is huge. Tourism accounts for more than two times the cash transfers from rich to poor countries than governments give in aid. Although Europe, the Americas, East Asia, and the Pacific will account for 80 per cent of total arrivals, and thus continue to dominate in terms of volume, international tourists to South Asia are forecast to grow by more than six per cent, compared to a world average of just over four per cent. International tourist arrivals from 1950-2004 are depicted in Table 3.1.

Mountains are very important to the tourism industry. It is estimated that mountains account for roughly 15-20 per cent of the global tourism market, generating between 70 and 90 billion US dollars per year (FAO 2005). After coastal regions, mountains are thought to be second in global popularity as tourist destinations. Recent trends indicate a surge in the number of visitors to ecotourism destinations, mainly located in the mountains. Hiking, camping, mountaineering, rock-climbing, mountain biking, wildlife viewing, and other forms of non-consumptive recreation are in growing demand (Nepal 2003).

Tourism is also a major provider of employment and supports an estimated 74 million jobs directly and 215 million jobs (8.1% of the world total) indirectly. The industry has a gross turnover of about US \$4,218 billion (about 10% of the world's total gross domestic product).

International travel is only one aspect of tourism. In many countries, domestic tourism outweighs international arrivals in terms of volume and income generated (e.g., Bangladesh, India, and Pakistan). Domestic tourism is also predicted to grow strongly.

Table 3.1: International Tourist Arrivals, 1950-2004*

	World	Africa	Americas	Asia and the Pacific	Europe	Middle East
1950	25.3	0.5	7.5	0.2	16.8	0.2
1980	278.2	7.3	62.3	23.6	177.5	7.5
1990	441.0	15.2	92.8	57.7	265.3	10.0
1995	538.1	20.4	109.0	85.0	309.3	14.3
2000	680.6	28.2	128.2	114.9	384.1	25.2
2001	680.4	28.9	122.1	120.7	383.8	25.0
2002	700.4	29.5	116.6	131.1	394.0	29.2
2003	689.7	30.8	113.1	119.3	396.6	30.0
2004*	763.2	33.2	125.8	152.5	416.4	35.4
Average Annual Growth (%)						
1950-2000	6.8	8.3	5.8	13.2	6.5	10.2
1950-1960	10.6	3.7	8.4	14.1	11.6	12.3
1960-1970	9.1	12.4	9.7	21.6	8.4	11.5
1970-1980	5.3	11.7	4.0	14.2	4.6	14.9
1980-1990	4.7	7.6	4.1	9.4	4.1	3.0
1990-2000	4.4	6.4	3.3	7.1	3.8	9.7
2000-2004*	2.9	4.2	-0.5	7.3	2.0	8.8

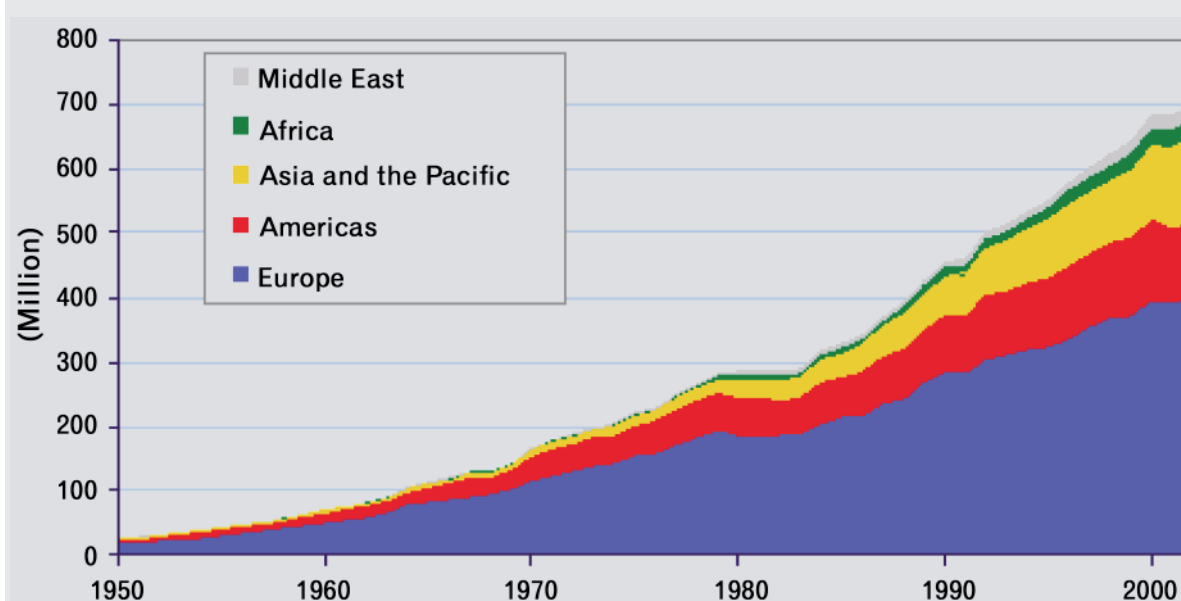

Source: UNWTO 2005

Overview of International Tourism

Growth in tourist arrivals

International tourist arrivals reached an all-time record of 763 million in 2004, which was an 11 per cent growth since 2003. Growth was common to all regions, but was particularly strong in Asia and the Pacific (+28%) and in the Middle East (+18%) followed by the Americas (+11%), Africa (+8%), and Europe (+5%) (Table 3.1). Asia and the Pacific gained almost half of all new arrivals, over 33 million. Europe came second with an increase in arrivals of 20 million. The only two subregions that did not break their previous records were North America and Western Europe, respectively falling 6 million and 1 million short of the volume recorded in 2000. In 2004, the majority of international tourists travelled for leisure, recreation, and holidays (about 52% or 395 million). Business travel accounted for some 16 per cent of the total (120 million) and another 24 per cent travelled for

other reasons, such as visiting friends and relatives, religious purposes or pilgrimages, and health treatments (185 million). About half of all international tourists arrived overland by road (45%) or rail (4%). Air transport represented 43 per cent of arrivals, and transport over water accounted for seven per cent.

Growth in tourism receipts

International tourism receipts grew in 2004 at a rate slightly lower than that of international tourism arrivals, namely nine per cent, after declining for the three previous years. International tourism receipts grew by an exceptional 25 per cent in Asia and the Pacific, following the 10 per cent loss experienced in 2003 on account of SARS. The fastest growing subregion was Northeast Asia (+30%). Growth was also particularly buoyant in the Middle East (+22%). Africa posted more modest growth (+5%), constrained by the results of Sub-Saharan Africa (+3%) after having been the star performer for the previous three years. The United States (US \$74 billion) continues to lead the table of the world's top tourism earners and saw a strong comeback in 2004, followed by Spain (US \$45 billion), France (US \$41 billion), Italy (US \$36 billion), Germany (US \$28 billion), United Kingdom (US \$27 billion), and China (US \$26 billion).

The year 2004 was definitely the year of full recovery in Asia and the Pacific as the region achieved a growth of 28 per cent and an estimated volume of 153 million tourist arrivals. International tourist arrivals to Northeast Asia grew by 30 per cent with major SARS-affected destinations fully recovering the losses of 2003 in terms of both arrivals and tourism receipts. In China, a recovery in inbound tourism was fully accomplished with a 27 per cent increase in tourist arrivals to a total of almost 42 million, thus amply surpassing 2002 figures. Destinations in South Asia (+17%) maintained momentum, after the already sound results obtained in 2003 (+10%). Tourism to the subregion grew to a total of approximately eight million arrivals for the first time, driven mainly by results registered in India (+24%), Sri Lanka (+13%), and the Maldives (+9%). International tourist arrivals to Oceania grew by 13% to more than 10 million.

World's top tourism destinations

In 2004, the top 10 tourism destinations in terms of arrivals accounted jointly for 363 million international tourist arrivals, or nearly half of the 763 million arrivals reported worldwide. In the ranking by receipts, the picture is similar with the top 10 world tourism earners representing more than half of overall tourism receipts (US \$321 billion). France maintains the leading position as the world's most visited destination with 75 million tourist arrivals in 2004. Spain ranks second with close to 54 million arrivals, followed by the US with 46 million arrivals, and China achieving an all-time record of almost 42 million tourist arrivals, with the number of tourists to the Tibet Autonomous Region expected to grow rapidly due to the opening of a new railway (see Box 3.2). The United

Box 3.2: Effect of the Qinghai-Tibet Railway on China's Inbound Tourism

The opening of the Qinghai-Tibet railway brings good opportunities for tourism development in the Tibet Autonomous Region. The railway removes the traffic 'bottleneck' that restricted tourism. Since 1 July 2006 when the railway was put into operation, Tibet tourism has boomed. Statistics show that from 1 July to 31 August 2006, 9.13 million domestic and international tourists visited Tibet, an increase of 54 per cent compared to the same period the previous year. Among them, 47,000 were inbound tourists and 866,000 were domestic tourists, an increase of 47.5 per cent and 54.4 per cent respectively. Foreign currency earnings reached US \$20.48 million (an increase of 34.7%), with domestic tourist revenues reaching 782.45 million Yuan (an increase of 53.7%). The total tourism gross revenue reached 943.22 million Yuan, and increased by 48.6%. (US\$ 1 = 7.55 Yuan in 2007)

Source: Tibet Tourism Bureau 2006

Kingdom maintained the sixth position with almost 28 million arrivals in 2004 (+12%). Hong Kong (China), Mexico, Germany, and Austria follow in the remaining positions with volumes of around 20 million tourists each.

Tourist Arrivals in the South Asian Region

Table 3.2 presents tourist arrivals in the Asia-Pacific region. Northeast Asia accounted for about 57 per cent of the 153 million tourists to this region in 2004. South Asia's share was about five per cent or 7.5 million tourists (Table 3.2). The number of tourists to this region in 1995 was about five million, which increased gradually to about 7.5 million in 2004 at an average growth rate of about 6.5 per cent (1995-2004). India accounts for more than 50 per cent (3.4 million) of the tourist arrivals to South Asia; all other countries in the subregion reported less than a million tourists in 2004.

The share of receipts also shows a similar pattern (Table 3.3). South Asia accounts for only about six per cent (about US \$7 billion in 2004) of the total tourism receipts, with India having the largest share. The results clearly indicate that the scope to earn more tourism income in South Asia is vast, given the huge potential of this region in terms of natural and cultural heritage.

	International Tourist Arrivals ('000)						Market Share in the Region		Change%		Average Annual Growth%	
	1990	1995	2000	2002	2003	2004*	1995	2004*	03/02	04*/03	90-95	95-00
Asia & the Pacific	57,740	85,024	114,863	131,108	119,255	152,503	100.0	100.0	-9.0	27.9	8.0	6.2
North-East Asia	27,969	44,115	62,525	74,127	67,595	87,576	51.9	57.4	-8.8	29.6	9.5	7.2
China	10,484	20,034	31,229	36,803	32,970	41,761	23.6	27.4	-10.4	26.7	13.8	9.3
South-East Asia	21,469	28,592	37,006	42,015	36,189	47,252	33.6	31.0	-13.9	30.6	5.9	5.3
Myanmar	21	117	208	217	206	242	0.1	0.2	-5.3	17.7	41.0	12.2
Oceania	5,152	8,085	9,247	9,133	9,045	10,175	9.5	6.7	-1.0	12.5	9.4	2.7
South Asia	3,150	4,233	6,086	5,833	6,427	7,501	5.0	4.9	10.2	16.7	6.1	7.5
Bangladesh	115	156	199	207	245	271	0.2	0.2	18.4	10.6	6.3	5.0
Bhutan	2	5	8	6	6	9	0	0	12.5	47.6	19.1	9.6
India	1,707	2,124	2,649	2,384	2,726	3,371	2.5	2.2	14.4	23.6	4.5	4.5
Iran	154	489	1,342	1,585	1,546	1,659	0.6	1.1	-2.5	7.3	26.0	22.4
Maldives	195	315	467	485	564	617	0.4	0.4	16.3	9.4	10.1	8.2
Nepal	255	363	464	275	338	360	0.4	0.2	22.7	6.5	7.3	5.0
Pakistan	424	378	557	498	501	648	0.4	0.4	0.6	29.4	-2.3	8.1
Sri Lanka	298	403	400	393	501	566	0.5	0.4	27.3	13.1	6.2	-0.1

Source: UNWTO 2005

Long-term prospects

UNWTO's Tourism 2020 Vision forecasts that international arrivals will reach over 1.56 billion by the year 2020, of which 1.18 billion are expected to be intraregional and 377 million long-haul travellers. The forecast is that by 2020 the top three receiving regions will be Europe (717 million tourists), East Asia and the Pacific (397 million), and the Americas (282 million). East Asia and the Pacific, South Asia, the Middle East, and Africa are forecasted to record growth at rates of over five per cent per year, compared to the world average of 4.1 per cent. The more mature regions, Europe and the Americas, are forecast to show lower than average growth rates. China will have 100 million outbound travellers and is expected to become the fourth largest source of outbound travel in the world by 2020.

Table 3.3: International Tourism Receipts in Asia-Pacific by Country of Destination

	International Tourism Receipts (USD million)						Market Share in the Region		Change %		Average Annual Growth%	
	1990	1995	2000	2002	2003	2004*	1995	2004*	03/02	04*/03	90-95	95-00
Asia & the Pacific	46,667	81,988	90,383	99,069	94,855	124,960	100.0	100.0	-4.3	31.7	11.9	2.0
North-East Asia	23,001	38,017	46,030	51,721	47,104	63,565	46.4	50.9	-8.9	34.9	10.6	3.9
China	2,218	8,730	16,231	20,385	17,406	25,739	10.6	20.6	-14.6	47.9	31.5	13.2
South-East Asia	14,479	26,696	26,004	27,643	24,335	31,752	32.6	25.4	-12.0	30.5	13.0	-0.5
Myanmar	9	151	162	99	116	136	0.2	0.1	17.2	17.2	75.8	1.4
Oceania	7,158	13,871	13,844	14,461	17,605	22,311	16.9	17.9	21.7	26.7	14.1	0
South Asia	2,029	3,405	4,505	5,243	5,811	7,332	4.2	5.9	10.9	26.2	10.9	5.8
Bangladesh	11	25	50	57	57	67	0	0.1	0	17.9	17.8	14.9
Bhutan	2	5	10	8	8	2	0	0	4.3	50.0	20.1	14.9
India	1,513	2,582	3,168	2,918	3,533	4,769	3.1	3.8	21.1	35.0	11.3	4.2
Iran	61	67	467	1,357	1,033	1,074	0.1	0.9	-23.9	4.0	1.9	47.5
Maldives	89	211	321	337	402	479	0.3	0.4	19.2	19.1	18.8	8.8
Nepal	64	177	158	103	199	...	0.2	...	93.2	...	22.6	-2.2
Pakistan	156	110	81	97	136	186	0.1	0.1	39.8	36.9	-6.7	-5.9
Sri Lanka	132	226	248	363	441	513	0.3	0.4	21.5	16.3	11.4	1.9

Source: UNWTO 2005

Tourism and the World Economy

Tourism demand depends strongly on the economic conditions in major generating markets. As disposable incomes increase, so will the demand for tourism. Likewise a tightening of the economic situation will often result in a decrease or trading down of tourism spending. In 2003, international tourism receipts (Table 3.3) represented approximately six per cent of worldwide exports of goods and services (expressed in US\$) (Table 3.4). When considering service exports exclusively, the share of tourism exports increases to nearly 30 per cent.

It is interesting to note the relationship between changes in the world GDP growth and tourism growth. When the world economic growth exceeds four per cent, the growth of tourism volume tends to be higher (see Figure 3.1), and when GDP growth falls below two per cent, tourism growth tends to be lower. In the period from 1975-2000 tourism increased at an average rate of 4.6 per cent per year.

Table 3.4: World Exports of Merchandise and Commercial Services

	US \$ billion	Share (%)	Share (%)
Total	9089	100	
Merchandise exports	7294	80	
Agricultural products	674	7	
Mining products	960	11	
Manufacturers	5437	60	
Other	223	2	
Commercial Services	1795	20	100
Transportation	405	4	23
Travel	525	6	29
Other	865	10	48

Source: World Trade Organisation, UNTWO 2007

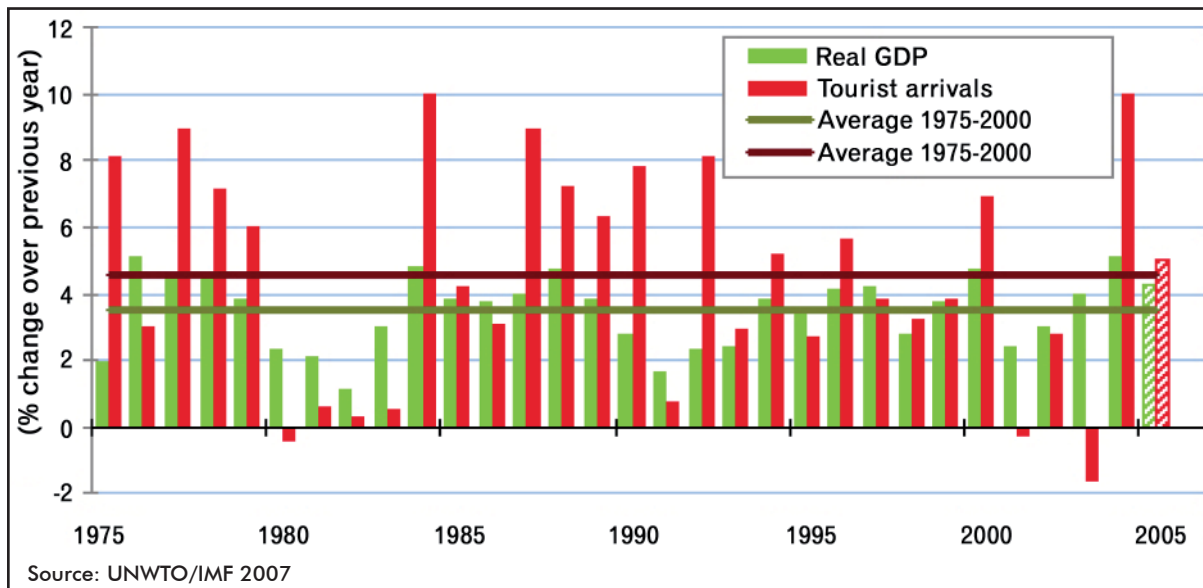

Figure 3.1: Economic growth (GDP) and international tourist arrivals

Impacts of Tourism

While discussing the impacts of tourism, the focus here will be primarily on mountain areas, specifically the Himalayas. Tourism generates employment and income opportunities for local people. Local jobs are created through opportunities to work for instance as guides and porters, in lodges, selling food items and general supplies to tourists, renting mules, yaks, and camp grounds, and performing cultural shows and so on. These often create many opportunities for women as well. A major concern though has been the negative impacts of tourism on the environment (deforestation, pollution of water sources, littering, and so forth). Some scholars also argue that tourism has had negative impacts on local culture and values. Some of the specific impacts of tourism in mountain areas cited in the literature are discussed briefly below.

Environmental impacts

Pollution, littering, land-use change

Mountain tourism has impacts on pollution and littering and can cause land-use change.

- More land is used to build lodges, tea stalls, and camp grounds.
- Land is left fallow to rent out as camp grounds.
- Trekking trails and surrounding areas are littered with plastic, paper, and bottles.
- Aesthetic beauty is adulterated by unpleasant signboards (e.g., for Coca Cola, Pepsi, instant noodles).
- Water is polluted for local people as well as tourists by unmanaged toilets.
- The amount of waste, both biodegradable and non-biodegradable, is increasing.

Forests and firewood

Tourism also has impacts on forests and firewood in the mountains; for instance, in the following ways.

- Tourists outnumber local people in some mountain areas, and the increase demand for firewood leads to deforestation.
- Although group tourists are expected to use alternative energy sources, FITs depend on lodges that continue to use firewood, and the porters who accompany both types of tourist also rely on scarce firewood.

- Growing seasons (crops and trees) in the mountains are extremely short and, hence, the replenishment of firewood requires extremely long periods.
- Selling firewood to tourists has become an occupation for some people.
- Use of firewood and timber in some mountain areas is greater than the natural growth of local forests.

Economic impacts

Tourists spend a great amount of money to visit mountain areas. They have to purchase an air ticket and visa and, after arrival in the host country, pay for accommodation, food, and other services. Mountaineers pay royalties to climb certain peaks. Some of this expenditure accrues as income to the government and some to different service providers. The government also benefits from taxes paid by tourists when they consume different goods and services. In mountain areas, tourism generates income through trekking fees, park entrance fees, mountain climbing permits, and directly when purchasing food (fruit and vegetables or poultry), lodging, and guiding and portering services in the area.

However, per capita tourist expenditure remains low and the contribution of tourism revenue to GDP has remained below five per cent. A large part of the income earned from tourism in mountain areas leaks out while providing goods and services to the tourists. The leakage of tourism income in mountain areas is substantial. In Nepal, for example, mountain lodges purchase many food items from Kathmandu, Pokhara, and other large centres to generate tourism services. Many items, such as rice, vegetables, milk, eggs, and meat, which are available locally, are purchased from outside the community and thus increase the leakage of tourism income. Although not all leakages can be stopped, they can be minimised if some items are produced locally for sale to the tourism sector. Developing greater complementarity between tourism and the community is one sure way to enhance sustainability. Tourism can benefit mountain areas substantially if it is integrated into the local production system.

Sociocultural impacts

The impacts of tourism on local cultural traditions and values are difficult to assess. In the short run, impacts may be observed to be negative (or positive) and in the long run these impacts may be positive (or negative). It is not easy to separate precisely the impacts of tourism on cultural practices as people also travel, educate themselves, trade, watch TV, listen to the radio, and are connected to the outside world through the Internet, all of which can bring about change in the community. Furthermore, sociocultural impacts are often hard to disentangle from wider processes of development or globalisation. Changes in people's behaviour, dress, lifestyle, family and social structure, and values and expectations; the decline in local support for local traditions and institutions; people's preference for tourist-related jobs over education; the pollution of sacred places; and changes in traditional architecture are generally cited as instances of negative impacts of tourism on mountain culture. On the other hand, there are also many positive impacts. Tourism can increase pride in local culture and traditions and provide an incentive to conserve important cultural and heritage sites and traditions. It can also contribute to the wider development and awareness of communities. Tourism has given some local people a basic understanding of another language (mostly English) and has in some cases promoted awareness about health and hygiene.

Infrastructural development

Tourism has promoted infrastructural development in some remote areas. The construction of airstrips, bridges, and trails in some parts of the Himalayas has been driven by tourism development. Tourism can also lead to voluntary giving of resources by tourists for the construction of communal infrastructure, such as hospitals, schools, or toilets, which benefit the poor and the community as a whole.

Impacts on women

Many women are employed in lodges and tea houses. In fact tourism has created a wide range of formal and informal employment opportunities for women as can be seen from developments in Nepal. Many mountain lodges are managed by women and perhaps, in mountain areas, more women than men are employed in this sector. Women have also benefited significantly from tourism through micro-enterprise development, e.g., in the form of producing handicrafts, weaving, selling honey, agro-processed products, and tea stalls.

Tourism has also helped women to undertake highly specialised and skilful activities such as climbing Mt. Everest, which undoubtedly has improved their position in society. Furthermore, tourism often allows women to carry out new roles for themselves and their families, both at home and within the local power structures (community-based organisations [CBOs], local governments, and non-government organisations [NGOs]), and to become increasingly involved in the decision-making process.

Women from the Sherpa community and other mountain communities have been trained as doctors and increasing numbers of women from mountain areas are enrolling in higher education. Perhaps the full impacts of tourism on women are just beginning to be seen.

Who benefits and who bears the costs of mountain tourism?

As tourism is seasonal in mountain areas, so are the benefits. At the same time, because of the low level of development in mountain areas, a large part of the income earned by local people leaks out while purchasing items (from outside the region) to produce goods and services for tourists. It is important to realise that not all economic, sociocultural, and environmental impacts (positive or negative) are evenly distributed among the mountain population. Unfortunately, many of the burdens of tourism are borne by the more disadvantaged in society, notably the poor and women. Estimates from the Asian Development Bank and the Ministry of Culture, Tourism, and Civil Aviation in Nepal suggest that, on average, only six per cent of tourist expenditure actually goes to rural areas (Touche Ross 1990). Studies by SNV show an even less rosy picture for the remote countryside, estimating that of the 57 million USD per year spent by trekking tourists visiting rural areas in the hills and mountains of Nepal, less than 10 per cent is spent locally, with remote districts receiving less than one per cent of the total tourism revenue (SNV 2003b). A review of 24 case studies in Asia indicated economic gains for all sections of the community, but with those better off gaining the most (Shah 2000). Some of the main reasons why the poor seem to have been unable to benefit much from tourism are that the linkages between tourism and the local production system are weak and supply-side planning and management have been poor and, in some cases, even completely ignored (Kruk and Banskota 2007).

Major Issues and Constraints

Research has shown that mountain tourism often has different constraints that prevent benefits from reaching local people and which leave negative imprints on the social, natural and cultural environment, and economic structure (CREST 1995). To promote the benefits of tourism among the wider mountain community, while at the same time minimising negative impacts, the following issues and constraints need to be addressed.

- A clear policy perception is needed of what and how tourism is expected to play a role in local and regional development in the mountains.
- Destination planning should be carried out with a strong supply side orientation to develop strong links between tourism and the local production system so that local people are able to retain a larger share of tourism revenue locally.

- Carrying capacity concepts should be operationalised for an appreciation of the critical environmental, economic, social, cultural, and managerial factors affecting carrying capacity (see also Tool 2, Volume 2).
- Sustainable generation and equitable sharing of revenue from tourism are essential.
- Local-level institutions should be established as a means of linking tourism with development. This is also the first step towards initiating a process of participatory planning of tourism and local development. It becomes extremely important to involve all the stakeholders in planning from the very beginning of the development process.
- An information base on the demand side of tourism (such as the size and composition of visitors, their interests and expenditure patterns, willingness to pay, expectations, and the quality of their experience) should be established in order to understand what factors attract visitors. Such information is virtually non-existent in the region. Periodic visitor surveys are essential.

Training in lodge management, hygiene, cooking, housekeeping, and local guiding skills, both related to culture and nature, should also link with local employment opportunities. For this, however, training and manpower needs have to be identified discretely in terms of real requirements and opportunities at the local level.

Concepts and Principles of Sustainable Mountain Tourism

This chapter covers

- The concepts and guiding principles of sustainable development and of sustainable tourism and their interconnection
- The concepts of carrying capacity and limits of acceptable change
- The concept of pro-poor tourism as a new approach to sustainable mountain tourism

Introduction: Sustainable Development and Mountain Tourism

Concept of sustainable development

The concept of sustainable development grew out of the limits to growth debate of the early 1970s. This debate discussed whether or not continuing economic growth would inevitably lead to severe degradation and societal collapse on a global scale. By the late seventies, it was realised that economic development could not be sustained without the conservation of the environment. The World Conservation Union (IUCN) in its world conservation strategy report in 1980 first defined the concept of sustainable development as a process which allows development to take place without degrading or depleting the resources so that they are able to renew themselves to support future as well as current generations. Several years later, the World Commission on Environment and Development, popularised and promoted the concept of sustainable development and emphasised the need to address development and the environment simultaneously (Brundtland 1987). It defined sustainable development as “the development that meets the needs of the present generation without compromising the ability of future generations to meet their own needs.” In the same year, the World Bank also reached the conclusion that economic growth, poverty alleviation, and sound environmental management are in many cases mutually consistent objectives (1987).

Dimensions of sustainability

Sustainable development is a multidimensional concept embracing essentially three dimensions or pillars: economic, social, and environmental sustainability (McKercher 2003).

- **Economic sustainability:** Economic sustainability means generating prosperity at different levels of society and addressing the cost effectiveness of all economic activities. It is about the viability of enterprises and activities and their ability to be maintained in the long term. It seeks to maximise human welfare within the constraints of existing capital stock and technologies and ensures the economically efficient allocation of resources that can support future generation.

- **Social sustainability:** Social sustainability means respecting human rights and equal opportunities for all in society. It requires an equitable distribution of benefits, with a focus on alleviating poverty. There is an emphasis on local communities, maintaining and strengthening their life support systems, recognising and respecting different cultures, and avoiding any form of exploitation. It emphasises a development process that empowers people and their social organisations (control over their lives). It ensures that the development process is compatible with the culture, values, and identity of the people and community.
- **Environmental sustainability:** Environmental sustainability means conserving and managing resources, especially those that are not renewable or are precious in terms of life support. It requires action to minimise pollution of air, land, and water and to conserve biological diversity and natural heritage. It stresses preserving the integrity of ecological subsystems for the overall stability of the global ecosystem. It ensures the maintenance of essential ecological processes, biodiversity, and biological resources.

It is important to appreciate that these three pillars are in many ways interdependent and can be both mutually reinforcing or in competition. The real challenge for delivering sustainable development means striking a balance between them as demonstrated in Figure 4.1 (Venn diagram; for more information on Venn diagrams, see Volume 2, Tool 17).

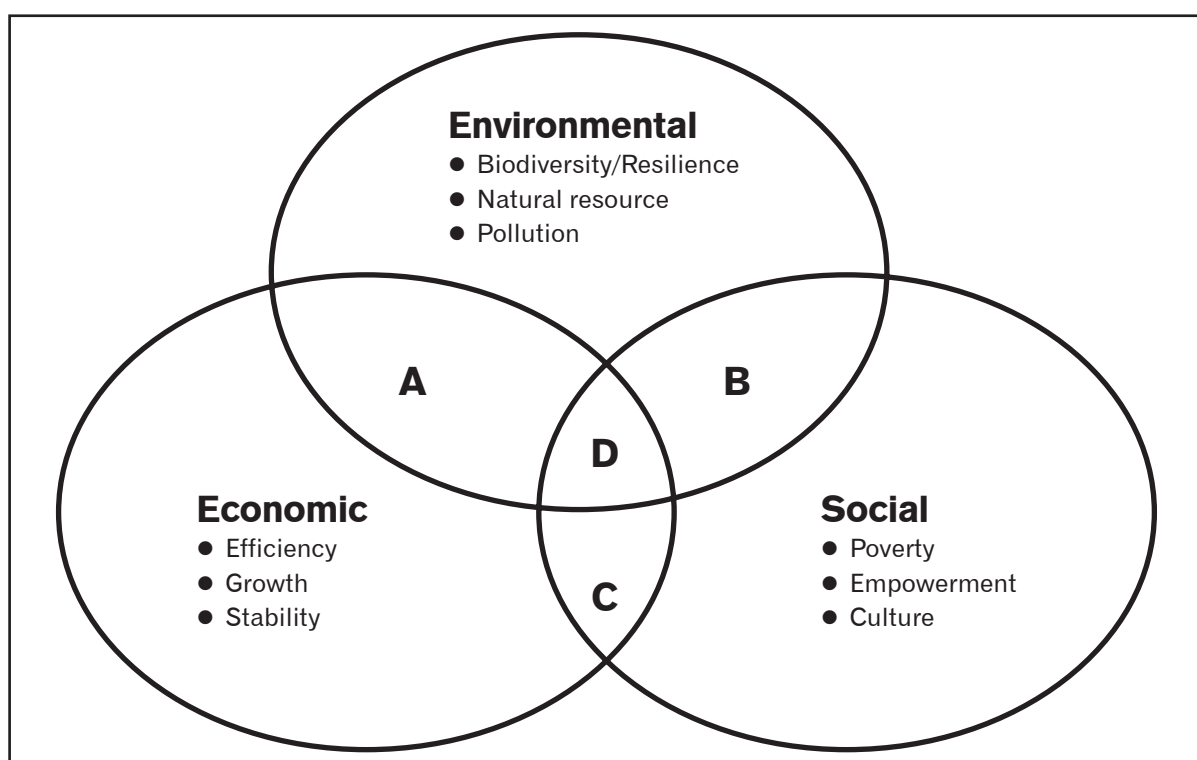

Figure 4.1: Balancing the dimensions of sustainable development

While the above definitions provide a neat summary, the meaning and application of the concept of sustainable development is seldom easy because it is broad and complex. While sustainable development allows for economic development within the parameter of resource conservation, sustainability is often viewed from two opposite angles. At one extreme is economic sustainability, where what is being sustained is the economy at whatever cost, at the other is ecological sustainability as a dominant feature, where the natural environment takes priority over economic development. However, all economic, social, and environmental considerations need to be addressed and balanced. Sustainable development is based on principles of sound husbandry of the world’s resources, and on equity in the way those resources are used and their benefits distributed.

Sustainable development has different key principles:

- **Inter-generational equity** means that the range of activities and the scope of ecological diversity available to future generations should at least be as broad as for current generations.
- **Social justice and poverty alleviation** means improving the well-being of all residents in a community and not just benefiting the powerful or the rich.
- **Public participation in decision-making processes** means giving all stakeholders a role to play and enabling communities to make decisions on a collective basis rather than having them imposed by external forces.
- **Environmental conservation as an integral component of economic development** implies that economic development without environmental conservation is no longer acceptable.
- **Dealing cautiously with risk and uncertainty** means that in situations where the environmental impacts of activities are not known, the preferred option is to proceed cautiously or not at all until the likely impacts can be determined (McIntyre et al. 1993).

Defining sustainable mountain tourism development

Sustainable mountain tourism concepts have grown out of the idea of sustainable development. The principles of sustainable development entail a longer-term and more cautious approach to development to ensure that future generations can enjoy at least the same quality of life as the present generation. The UNWTO defined sustainable tourism as early as 1988 as “tourism which leads to management of all resources in such a way that economic, social, and aesthetic needs can be fulfilled while maintaining cultural integrity, essential ecological processes, biological diversity and life support systems”. Put differently, sustainable mountain tourism means developing a product that “meets the needs of present tourists and host mountain regions while protecting and enhancing opportunity for the future”, leading to outcomes that improve the tourism product for the good of the economy, the environment, and the local community (UNWTO 1998).

As sustainability principles refer to the environmental, economic, and sociocultural aspects of tourism development, sustainable mountain tourism should do the following:

- Make optimal use of environmental resources that constitute a key element in tourism development, maintaining essential ecological processes and helping to conserve natural resources and biodiversity
- Respect the sociocultural authenticity of host communities, conserve their built and living cultural heritage and traditional values, and contribute to intercultural understanding and tolerance
- Ensure viable, long-term economic operations, provide socioeconomic benefits to all stakeholders that are fairly distributed – stable employment and income-earning opportunities and social services for host communities – and contribute to poverty alleviation

An agenda for sustainable tourism, consisting of twelve aims that address economic, social, and environmental impacts, has been developed by UNEP and UNWTO (2005). These twelve aims are as follows:

1. **Economic Viability:** To ensure the viability and competitiveness of tourism destinations and enterprises, so that they are able to prosper and deliver benefits in the long term
2. **Local Prosperity:** To maximise the contribution of tourism to the economic prosperity of the host destination, including the proportion of visitor spending that is retained locally
3. **Employment Quality:** To strengthen the number and quality of local jobs created and supported by tourism, including the level of pay, conditions of service, and availability to all without discrimination of gender, race, disability, or in other ways
4. **Social Equity:** To seek a widespread and fair distribution of economic and social benefits from tourism throughout the recipient community, including improving opportunities, income, and services available to the poor and marginalised or socially excluded

5. **Visitor Fulfilment:** To provide a safe, satisfying, and fulfilling experience for visitors, available to all without discrimination because of gender, race, disability, or in other ways
6. **Local Control:** To engage and empower local communities in planning and decision-making about the management and future development of tourism in their area, in consultation with other stakeholders
7. **Community Well-being:** To maintain and strengthen the quality of life in local communities, including social structures and access to resources, amenities, and life support systems, avoiding any form of social degradation or exploitation
8. **Cultural Richness:** To respect and enhance the historic heritage and the authentic culture, traditions, and distinctiveness of host communities
9. **Physical Integrity:** To maintain and enhance the quality of landscapes, both urban and rural, and avoid the physical and visual degradation of the environment
10. **Biological Diversity:** To support the conservation of natural areas, habitats, and wildlife and minimise damage to them
11. **Resource Efficiency:** To minimise the use of scarce and non-renewable resources in the development and operation of tourism facilities and services
12. **Environmental Purity:** To minimise the pollution of air, water, and land and the generation of waste by tourism enterprises and visitors

Key challenges for sustainable mountain tourism

Mountain tourism development, like other forms of development, faces major global challenges that threaten the sustainability of the industry. Some of these global challenges are given below:

- **Managing dynamic growth:** The doubling of international tourist movements predicted for the next 15 to 20 years will place considerable pressure on the very resources on which tourism depends, if growth is not properly planned and managed.
- **Climate change:** Climate change is a major issue for the long-term sustainability of mountain tourism in two senses: firstly, climate change will have consequences for tourism and, secondly, tourism is a contributor to climate change. It is estimated that tourism may contribute up to 5.3 per cent of global anthropogenic greenhouse gas emissions, with transport accounting for about 90 per cent of this.
- **Poverty alleviation:** The potential for tourism to contribute to poverty reduction in mountain areas is increasingly being recognised. This is partly because tourism is often a new source of revenue in rural areas where three-quarters of the world's poor are found together with rich cultural and natural tourism assets. The challenge is to find ways of channelling visitor spending towards poor people, minimising leakages, and maximising linkages with local production systems.
- **Support for conservation:** The need to generate more financial resources to support conservation, both of natural, cultural, and historic sites and resources is a worldwide issue.
- **Health, safety, and security:** In recent years, uncertainty about the health and safety of travellers and of certain destinations has caused significant fluctuations in tourism flows. Although this may be a short-term phenomenon, it should be regarded as a global issue for the sustainability of mountain tourism.

The challenge is finding an acceptable balance among the following key elements for sustainability of mountain tourism: preserving the mountain resource base for future generations; maintaining the productivity of the resource base; maintaining and protecting the biodiversity and heritage (culture and history); and ensuring equity within and between generations, and in and between different gender groups, ethnic groups, rural and urban groups, and different economic classes, and so forth.

Tourism Carrying Capacity and Limits of Acceptable Change

Concept of tourism carrying capacity

The notion of carrying capacity and limits of acceptable change are at the core of the concept of sustainable tourism. The UNWTO defines the carrying capacity for tourism as “the maximum number of people that may visit a tourism destination at the same time without causing destruction of the physical, economic, and sociocultural environment and an unacceptable decrease in the quality of visitors’ satisfaction.”

Carrying capacity should be understood as the maximum level of visitor use and related infrastructure that an area can accommodate, i.e., a threshold beyond which deterioration of the resources, diminished visitor and host satisfaction, and unacceptable adverse impacts on the local area (natural or sociocultural environment) can be expected to occur. Carrying capacity is a multidimensional and dynamic concept and varies depending on place, season, and time; user behaviour and expectations; facility designs; and policy limitations. As a measure or indicator of sustainability, carrying capacity offers an early warning system for problems resulting from over-capacity and/or poor tourism planning or management of tourist destinations. More information on how the concept of carrying capacity can be used as a tool can be found in Volume 2 (Tool 2).

Dimensions of carrying capacity

Appreciation of the complexities involved in defining carrying capacity has resulted in the development of different components that can be broadly grouped into environmental, economic, and social behavioural aspects (Box 4.1). The application of different aspects of the concept in the case of Upper Mustang in Nepal is shown in Boxes 4.2, 4.3, and 4.4.

Biophysical or environmental carrying capacity

Environmental carrying capacity (also known as biophysical carrying capacity) can be further split into biological carrying capacity (dealing with flora and fauna) and physical carrying capacity (dealing with soil, water, and geomorphology). Researchers have endeavoured to identify environmental thresholds beyond which physical and biological matters are modified by human interaction. Environmental carrying capacity is a range of limits rather than a single fixed carrying capacity. These limits should be determined according to a combination of environmental resource thresholds, investment options, and management policies.

Economic carrying capacity

Economic carrying capacity is defined as the ability to absorb tourism development without squeezing out the desirable local development functions. It is a measure of the number of people that may be welcomed to a location before the economy of the area is adversely affected, for instance in the form of economic leakages, inflation, creation of scarcity, and so forth.

Social carrying capacity

Social carrying capacity, also called behavioural carrying capacity, is defined as the extent of quality of activity allowed before users (visitors and the host population) perceive the environment as negatively changed compared to before. It relates to user perception of the number of other people that they feel comfortable with in any given environment. It differs from physical carrying capacity in that exceeding the social carrying capacity affects both the hosts’ and the users’ experiences rather than the physical environment itself.

Box 4.1: Dimensions of Tourism Carrying Capacity

Environmental	Physical	Refers to the amount of suitable land available for facilities and includes the finite capacity of the facilities to cope with visitor pressure. A measure of the number of tourists that may be accommodated on a site.
	Biological/ Ecological	The limit of acceptable impacts on the flora, fauna, soil, water, and air quality. A measure of the number of people that may be accommodated on a site before damage occurs to the environment.
Economic		The ability to absorb tourism development without squeezing out desirable local development functions. A measure of the number of people that may be welcomed to a location before the economy of the area is adversely affected.
Social Behavioural or Perceptual		The level of impacts tolerable before the visitors' experiences are impaired. It also includes the host population and culture and individual perceptions of crowding.

Box 4.2: Environmental Carrying Capacity in Upper Mustang, Nepal

Environmental Factors/ Indicators	Present Status	Present Impacts of Tourism	Implications for the Future
Condition of Forests	Very sparse forest cover in a firewood and fodder deficient context; excessive deforestation; limited private plantation	Maybe high because of the use of local fuelwood by porters	Low regeneration capacity, some scope for community plantation in irrigable areas; scope for alternative energy technology
Littering/Garbage/ Pollution	Littering/garbage/ pollution fairly low	Little visible at present	Limited environmental pollution/degradation at present; needs better monitoring in future
Wildlife Habitat	Fairly good as settlements and tourist areas frequented are far from wildlife habitats	Very little or none	Damodar Kund area is rich in wildlife; livestock depredation by wildlife is reported; better protection of unique flora and fauna needed
Condition of Pastures	Some degradation of pastures but can be used sustainably with better grazing systems	Very little impact due to tourism	Livestock density at present is fairly high; with better balance, pastures can be managed sustainably
Overall Environmental Carrying Capacity (Perception)	Environmental carrying capacity remains moderate at present	Tourism impacts are low at present.	Alternative energy technology and sustainable pasture management called for

Source: Sharma 2000b

Box 4.3: Economic Carrying Capacity in Upper Mustang, Nepal

Economic Factors/ Indicators	Present Status	Present Impacts of Tourism	Implications for the Future
Agricultural Conditions	Scarce agricultural land; low productivity of agriculture as well as livestock; increasing use of livestock manure for energy	Very little as tourists rarely rely on local purchases; demand for animal fodder has increased	Has limited potential for diversification; animal husbandry becoming less viable
Levels of Food Sufficiency; Incidence of Poverty	Very low per cent of food-sufficient households; high incidence of poverty; very low tourism-induced income opportunities at present	Tourists do not depend on local supplies; tourism-induced inflation	Food deficiency bound to rise in the future; poverty will increase unless other income opportunities (including tourism) become available
Migration	Fairly high seasonal migration	Tourism has minimal impact on migration	Seasonal migration may rise in the future
Dependence on Trade	Fairly high	Moderate; imports may have increased due to tourism	Rise in tourism will induce growth in trade thus enhancing carrying capacity
Impacts of Tourism on Local Employment/ Income Opportunities	Very few opportunities opened by tourism	Limited impacts of tourism on 'local' employment and income	Linkage of tourism has to be induced through innovative efforts
Local Human Resource Development with Respect to Knowledge and Technology	No systematic efforts underway at present	Very little inducement for local human resource development	Scope for human resource development related to tourism and energy exists in areas
Overall Economic Carrying Capacity (Perception)	Economic carrying capacity remains extremely limited.	Tourism at present has limited impacts on economic carrying capacity	Needs to be enhanced through better management of productive resources

Source: Sharma 2000b

Box 4.4: Social Carrying Capacity in Upper Mustang, Nepal

Sociocultural Factors/ Indicators	Present Status	Present Impacts of Tourism	Implications for the Future
State of Monasteries/ Cultural and Religious Monuments	No detailed inventory of monasteries/ gompas; inadequate maintenance and renovation	Very little	Need to put emphasis on the awareness of cultural heritage through better guidance services; inventory, maintenance, and renovation required; tourists should not interfere with religious rituals; monitoring of impacts necessary
Religious Values, Festivals and Crafts	Relatively intact; exploitation based on traditional feudal relationships exists; Teeji festival is used to attract tourists; craft production remains little affected by tourism	Very little impacts on values, festivals, and craft	Tourism has helped serve feudal interests; although incidence of theft of religious artefacts remains very rare, increasing differences in earnings from tourism could exacerbate it in the future; local crafts that are of interest to tourists need to be identified and promoted.
Effectiveness of Traditional Institutions	Fairly effective; however, decision making is limited to well-off households	Very little	The poor are at a disadvantage in traditional institutions; need to nurture/reorient institutions for local participatory development
Literacy	Very low	Very little as tourists rarely come in contact with locals	Levels of literacy need to be improved. Literacy needs to be tied to employment opportunities.
Health Condition	Poor	Little	Health facilities, sanitation, and basic health care have to be improved.
Hosts Population's Perception of Tourists	Well-off segment of population is probably disposed to tourism; the poorer sections seem bewildered	Some impacts on well-off households; none or very little on the poor; few incidences of begging	Tourism needs to be made relevant for broadly shared local development
Visitor Satisfaction	Moderate	Very little	Need for better destination planning to increase visitor satisfaction; need to plough tourism revenue into local development to attract discerning tourists
Overall Social Carrying Capacity (Perception)	Social carrying capacity is moderate at present, but could be enhanced	Limited impacts of tourism on improving the carrying capacity	Better awareness and facilities can enhance carrying capacity

Source: Sharma 2000b

Coping with saturation of carrying capacity

Whether the carrying capacity is carefully planned or just happens over time, there is the danger that at some point the carrying capacity of either the natural or social environment or the infrastructure will be reached. When carrying capacity saturates, the tourism experience will naturally begin to decline. Some of the negative impacts resulting from saturation of carrying capacity may include the following:

- Deterioration of the natural ecology and scenic areas due to overdevelopment and intensive use
- Pollution of rivers and underground water due to improper sewerage and solid waste disposal
- Insufficient capacity of the utility service during peak use periods
- Pedestrian and vehicular congestion and resentment between host community and tourists because of overcrowding of tourist areas
- Other social and/or cultural problems

Depending on the saturation level of the tourist sites and areas, different coping strategies can be applied by management bodies:

- Increasing the capacity by expanding the capacity of transport and other service facilities including an awareness programme to change visitor behaviour
- Dispersing the pressure through diversification of tourism products and changing incentives
- Limiting the number of tourists either through higher prices, closure of the area, or the establishment of a (entry) quota

Control methods include the regulation of volumes using rules and prices. Regulatory measures may be in the form of permits, queuing, space allocated for activities, and time rationing. Price measures may include taxing the user externalising impacts and penalties to control littering, and so forth.

Carrying capacity can be expanded if it is properly planned and managed. Box 4.5 illustrates how Austria, being a mountainous country almost half the size of Nepal in terms of both land area and population, is able to sustain and accommodate 65 times more tourists than Nepal.

How to identify the carrying capacity of a tourism site or destination is further explained in Volume 2 (Tool 2).

Box 4.5: Carrying Capacity Example in Mountain Areas: Nepal versus Austria

Indicator	Unit	Austria	Nepal	Variance
Land Area	km ²	83,856	147,181	Nepal is almost double the size of Austria.
Population	million	7.82	19.2	Nepal's population is 2.5 times larger than Austria's.
GNP per Capita	USD	20,380	180	About 113 person's incomes in Nepal make one person's income in Austria.
Tourists	'000	19,092	293	For one visitor to Nepal, there are about 65 visitors to Austria.
Tourism Receipts	Million USD	13,956	126	Austria exceeds Nepal's tourism receipts by 110 times.

Source: Gurung 1998

Limits of acceptable change

A recent approach to carrying capacity is the concept of limits of acceptable change. Limits of acceptable change relates to how much environmental change is permissible or acceptable among the host population, resource managers, and visitors. As it revolves around values rather than resources, it is necessary to distinguish between environmental and sociocultural change and the acceptability of these changes among resource managers and other stakeholders, such as policy-makers and the local population. Defining limits of acceptable change thus becomes a central issue in calculating carrying capacity. Key stages and the underlying process involved in limits of acceptable change are given in Box 4.6.

Stages	Process/steps
1. Specification of acceptable and achievable resources and social conditions defined by set of measurable parameters	1. Identify area, concern, and issues 2. Define and describe range of tourism activities/zoning 3. Select indicators of environmental resource conditions and social conditions
2. Analysis of relationship between existing conditions and those judged acceptable	4. Make inventory of resource and social conditions 5. Specify standards for resource and social indicators
3. Identification of management action needed to achieve conditions	6. Identify alternative recreational opportunities 7. Identify management actions for each alternative 8. Evaluate and select alternatives
4. Monitoring of indicators of conditions and evaluation of effectiveness of management actions	9. Implement action and monitor conditions

Based on these key stages and steps, limits of acceptable change are defined as the levels of use beyond which impacts overstep levels (thresholds) specified by an evaluative standard. The evaluative standards and thresholds are specified according to existing management objectives, the values of managers, and the preferences of visitors and the host population. Thus, the limits of acceptable change shift away from simply calculating numbers to an emphasis on monitoring the specific conditions subject to impacts. More specifically, the limits of acceptable change represent a reformulation of the concept of carrying capacity in the following ways:

- They concentrate on the management conditions rather than on use levels per se.
- They aim to determine how much acceptable change may occur and what management actions are required to control it.
- They focus on management of the environment and desirable social conditions.
- They represent a means by which various management options can be adopted to ensure that the level of acceptable change set by the management, local communities, or the government are not exceeded at any chosen site.
- They employ a combination of zoning standards and monitoring with the aim of preventing further degradation to an area and focus on explicit and measurable objectives to identify how much and what types of changes are acceptable.

To sum up, carrying capacity is not a single value but a multi-dimensional concept with a range of possible values determined according to the quality of experience that is being sought. Values,

perceptions, users, and activities need to be considered as part of the calculation of carrying capacity value. Carrying capacity must be considered in the context of prevailing management policies, and must be related to specific management objectives for a given tourism destination.

Pro-Poor Tourism (PPT) as a New Approach to Sustainable Tourism

More recently there has been a shift of focus in tourism development approaches, with less emphasis on numbers of international arrivals and foreign exchange revenues, and more focus on local, economic development, length of stay, and linkages to local community development. The concept of pro-poor tourism grew out of this shift in emphasis (Ashley et al. 2001).

Pro-poor tourism (PPT) is defined as tourism that generates net benefits for the poor. Benefits may be economic, but they may also be social, environmental, or cultural. PPT is not a specific product or sector of tourism; neither is pro-poor sustainable mountain tourism, but rather an approach to the industry. It aims to ensure that the poor are gaining more from tourism than they are losing. Therefore, as long as poor people reap net benefits, tourism can be 'pro-poor' (even if richer people benefit more than poorer people). The definition says nothing about the relative distribution of the benefits of tourism. The core aim of PPT strategies is to unlock opportunities for the poor, rather than to expand the overall size of the sector. However, experiences show that PPT cannot succeed without the successful development of the entire tourism destination in question.

Pro-poor growth in relation to sustainable tourism development is relatively untried and untested, and there is no blueprint. Nevertheless, early experience reveals a number of common lessons:

- PPT requires a diversity of actions, from micro to macro-level, including product development, marketing, planning, policy, and investment. PPT goes well beyond community tourism.
- A driving force for PPT is useful, but other stakeholders, with broader mandates and broader policy frameworks and initiatives outside tourism are critical.
- Location matters: PPT works best where the wider destination is developing well.
- The poverty impact may be greater in remote areas, although tourism itself may be on a limited scale.
- PPT strategies often involve the development of new products, particularly products based on local culture. But these should be integrated with mainstream products if they are to find markets.
- Ensuring commercial viability is a priority. This requires close attention to demand, product quality, marketing, investment in business skills, and inclusion of the private sector.
- Economic measures should expand both regular jobs and casual earning opportunities, while tackling both demand (markets) and supply (products) of the poor.
- Non-financial benefits (e.g., increased participation, access to assets) can reduce vulnerability; more could be done to address these.
- PPT is a long-term investment. Expectations must be managed and short-term benefits developed in the interim.
- External funding may be required and justified to cover the substantial transaction costs of establishing partnerships, developing skills, and revising policies (not generally as direct subsidies to enterprises).

The rationale for pro-poor tourism is that in most countries with high levels of poverty, tourism is significant (see Chapter 3). It is, therefore, important to maximise the potential benefits for the poor, and minimise the potential harm. A pro-poor tourism strategy needs to incorporate both of these elements.

PPT and other forms of ‘alternative’ tourism

PPT puts the poor at the centre of its attention and mainly focuses on unlocking opportunities for the poor at all levels. It overlaps with both ecotourism and community-based tourism, but is not synonymous with either. Ecotourism is mostly concerned with the environment, whereas community-based tourism primarily aims to increase local people’s involvement in tourism. Moving the sustainable mountain tourism agenda to tackle poverty alleviation requires action on a number of fronts:

1. Expanding the focus of mainstream tourism initiatives beyond mainstream destinations to destinations where many of the world’s poor live and/or recognising that many of the world’s poor live alongside mainstream destinations and their voices need to be heard
2. Putting the poor and poverty (including the environmental dimensions of poverty) at the centre of the sustainability debate, rather than just the environment
3. Moving beyond a community-based tourism focus to develop mechanisms that unlock opportunities for the poor at all levels and scales of operation

Pro-poor tourism is an approach to tourism rather than a particular form of tourism. It can be encapsulated in a set of principles, including in the following:

- **Participation:** Poor people must participate in tourism decisions if their livelihood priorities are to be reflected in the way tourism is developed.
- **Holistic livelihood approach:** The range of livelihood concerns of the poor – economic, social, and environmental, and short-term and long-term – need to be recognised. Focusing simply on cash or jobs is inadequate.
- **Distribution:** Promoting PPT requires some analysis of the distribution of both benefits and costs, and how to influence it.
- **Flexibility:** Blueprint approaches are unlikely to maximise benefits for the poor. The pace or scale of development may need to be adapted; appropriate strategies and positive impacts will take time to develop; and situations are widely divergent.
- **Commercial realism:** Ways to enhance impacts on the poor within the constraints of commercial viability must be sought.
- **Learning:** As much is untested, learning from experience is essential. PPT also needs to draw on lessons from poverty analysis, environmental management, good governance, and small enterprise development (Ashley et al. 2000).

Strategies for pro-poor mountain tourism

Strategies for PPT focus on three core areas: increased economic benefits, positive non-economic impacts, and policy or process reform. Within each core area, three distinct (but often overlapping) strategies are recommended:

- **Strategies focused on economic benefits**
 - Expansion of business opportunities for the poor
 - Expansion of employment opportunities for the poor
 - Development of collective benefits for the wider community – fees, revenue shares, taxes, donations
- **Strategies focused on non-economic impacts**
 - Capacity building, training, and empowerment
 - Mitigation of environmental impacts of tourism on the poor
 - Addressing competing use of natural resources
 - Improving the social and cultural impacts of tourism
 - Increasing access to infrastructure and services

- **Strategies focused on policy or process reform**
 - More supportive policy and planning framework
 - Increasing participation of the poor in decision making
 - Pro-poor partnerships with the private sector
 - Increasing the flow of information and communication

Box 4.7 gives an example from the Tourism for Poverty Alleviation Programme of Nepal.

Box 4.7: Putting Poverty at the Core: The Tourism for Rural Poverty Alleviation Programme (TRPAP) in Nepal

The Tourism for Rural Poverty Alleviation Programme (TRPAP) in Nepal was set up with the goal of contributing to the poverty alleviation objectives of the government through the review and formulation of policy and strategic planning for sustainable tourism development that is pro-poor, pro-environment, pro-women, and pro-rural communities. The programme is contributing to the national poverty alleviation goal through the development of rural tourism models, institutional set-up for sustainability, and by giving policy feedback to the government to help establish pro-poor tourism policies.

TRPAP has three specified objectives to support its goal of poverty alleviation.

- To develop rural tourism models for policy feedback.
- To set-up institutions from the grass-root level to the central level to look after tourism activities.
- To establish backward and forward linkages and review and formulate conservation-friendly tourism development policies and strategies.

Sustainable Mountain Tourism Planning and Management

This chapter covers

- The importance of mountain tourism planning and the planning process
- The supply components of mountain tourism products and their interrelationship
- A framework for monitoring the sustainability of mountain tourism (the visitors, industry, community, and environment or VICE model)

Introduction: Imperatives of Mountain Tourism Planning

Tourism planning is essential to allocate scarce resources (at the local, regional, or national level) to maximise output, income, and employment; minimise leakages; distribute benefits to wider communities; conserve the environment; and provide visitor satisfaction. Tourism planning must be comprehensive and consider all the relevant components of tourism such as attractions, transport, accommodation, information, and promotion. A tourism plan must demonstrate how tourism functions as a system; how services are provided; how sites are developed and managed; and how tourism products are developed, marketed, and promoted. Clearly, effective planning and management of mountain tourism are essential at the destination and site level, and at the national, regional, and international level, to maintain its integrity and to ensure that unique attractions are protected.

Given the large-scale and rampant poverty in mountain areas, tourism development alone cannot be considered a panacea for poverty alleviation in these regions. Tourism planning must seek to link mountain tourism to mountain community development in areas where tourism can play a leading role. It is essential that the complementarity of mountain tourism and mountain community development is maximised. This means maximising income and employment generation from tourism, on the one hand, and minimising tourism income leakages, on the other. This is possible only when tourism is properly designed and closely integrated with the local economy by establishing backward and forward economic linkages. Income and employment generation must serve as the stimuli for environmental conservation. For sustainability, local institutional development needs to be emphasised and the capacity of local people needs to be enhanced to manage mountain tourism at the local level.

As tourism is governed by international and domestic market forces, tourism planning should be market oriented. The forces of demand and supply must be carefully understood and integrated into a tourism plan. However, this does not necessarily mean that the government has a minimal role to play. In fact, the government has to play a very important role to make mountain tourism sustainable (see Chapter 7).

Although the process of tourism planning is often well understood, there are many barriers to its effective implementation. Unlike other sectors, planning sustainable mountain tourism is a complex

process for a number of reasons, namely the existence of multiple stakeholders with diverse views but fragmented control over the tourism destination; the nature of tourism products that often contain elements of public goods with externalities; the nature of its impacts, that can be both positive and negative, interrelated, and interdependent; the constraints for participation of the poor (e.g., because of low levels of capital); the seasonal nature of tourism, and the peculiar nature of tourism products (see Box 5.1) and the mountain context or specificities (see Chapter 1). Almost all sectors are involved in tourism planning. Coordination across different sectors is therefore a crucial factor in tourism planning and execution (see also Chapter 12).

Box 5.1: Peculiar Nature of Tourism Products

The following characteristics of the industry have to be taken into consideration in planning for tourism.

Intangibility: Tourism products cannot be easily evaluated or demonstrated in advance of the purchase. It is not possible to test out the tourism service before it is purchased.

Perishability: Tourism products cannot be stored for sale at a future time. Tourism services such as a hotel room or aircraft seat left vacant on a particular night or flight cannot be stocked for future use.

Inseparability: Tourism products are often consumed and produced simultaneously. Unlike other products, the production of tourism services and their consumption (by tourists) are inseparable because tourists must be present to consume the service where it is produced. As tourists cannot inspect tourist services before deciding to use them (see intangibility), the risks and uncertainty for consumers are high, and, thus, their need for reliable pre-purchase information is strong.

Heterogeneity: As in other service industries, tourism services are difficult to standardise. Tourism services differ and heterogeneity is a feature of the tourism sector.

Complementarity: As a tourism product is the combination of several sub-products that complement each other, the failure of one sub-product can seriously affect the total attractiveness of the product.

Seasonality: Tourism is influenced by seasonal factors such as agricultural cycles, weather patterns, economic fluctuations, holiday seasons in generation markets, and so forth. This pattern of seasonality can bring problems of unemployment, but can also be a blessing in disguise (i.e., in terms of regeneration of the environment, not colliding with agricultural harvesting seasons, and so on).

Dominant role of intermediaries: In contrast to most other industries where manufacturers have control over design, distribution, and promotion and pricing, travel sale intermediaries such as tour operators, travel agents, and hotel wholesalers play an important role in tourism marketing

Source: Cooper and Wanhill 1993

Components of a Tourism Plan

Supply components of a tourism product

A tourism product is a composite product comprised of five main supply components: attractions, services, transportation, information, and promotion. Figure 5.1 demonstrates how these supply components of tourism are closely interrelated and operated within a system.

- **Attraction:** A tourism product has to be attractive or else visitors will not visit the area. A country's natural beauty, history, culture, and people all determine attraction. Attractions are both natural and man-made. Attractions could be ecosystems, rare plants, animals, or cultural, historic, or heritage products, but they are developed and managed entities. Sustainable planning for tourism must place emphasis on those areas that have the best attractions and can be linked with other services.

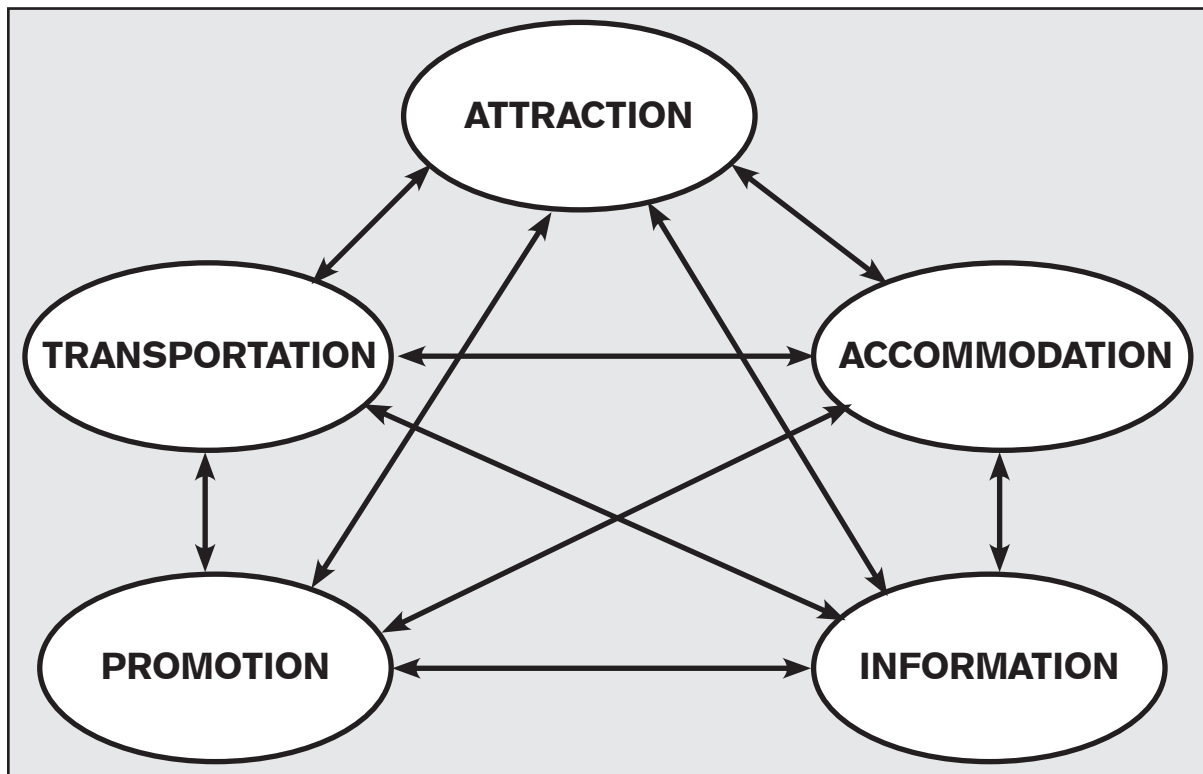

Figure 5.1: Supply components of a tourism product: the tourism system

- **Transport:** A network of efficient transportation is a must for a tourism product as it provides a critical linkage between the market source and destination. As all other supply components of tourism depend on transportation, there should be proper planning and managerial linkages between transportation, decision makers, and tourism developers.
- **Accommodation:** Accommodation complements other components of tourism. Service-oriented businesses (accommodation, food services, travel agencies and business, retail shops, restaurants, and so forth) generate the greatest economic impacts in terms of employment, income, and tax revenue, and they are the source of multiplier effects and linkages through indirect support of other sectors.
- **Information:** In contrast to advertising, which is intended to attract, information is generally descriptive (maps, magazines, articles, guidebooks, videos, and others). The objective of travel information is to provide visitors with an understanding of places and activities. Pre-travel information is as important as en route and on site information. Planned visitor centres offer a combination of information and services (food, retail sales, museum exhibits, publications, and others) to visitors.
- **Promotion:** Promotion generally takes place only after all other supply components of tourism have been developed. It is an important supply component of tourism and seeks to promote all the other components of tourism.

An alternative way to classify the supply components of tourism products is through the use of the 'Destination Mix', also popularly referred to as the 8 'A's'. The 8 'A's' that form the core of a tourism destination are (Shrestha and Walinga 2003):

- **Attractions:** Broadly categorised as natural resources, climate, culture, and history
- **Amenities:** Facilities and services like information, food, and beverage and infrastructure
- **Activities:** Such as trekking, adventure sports' activities, cultural activities, entertainment, shopping, and so forth
- **Accommodation:** Such as hotels, lodges, teahouses, home stays, camp sites, youth hostels, and so forth

- **Access:** Certain areas in the Himalayas owe their popularity to their accessibility. Many other places in the Himalayas contain great natural and cultural attractions (e.g., Dolpo in Nepal), but tourism is almost absent or very poorly developed due to lack of proper access or transportation. On the other hand, lack of accessibility can increase the attractiveness of the destination to some and offer magnificent views over the Himalayas
- **Affinity:** Hospitality, peacefulness, the friendliness of the population, attitude, and acceptance of tourism by host population and other stakeholders
- **Actors:** Including local communities, government agencies and departments (local and national), international NGOs (INGOs), NGOs, banks and donor agencies, business associations, accommodation and transport providers, restaurants, retail outlets, journalists, guidebook writers, tourists, and tour agents (at the local, national, and international levels), see also Chapter 7
- **Acts:** Rules, regulations, and policies relating to tourism

Tourism being a specialised service industry has a number of peculiar characteristics, which need to be fully understood if a tourism product is to be successfully planned, developed, and marketed.

Planning level or scale

Tourism planning needs to be approached on four different levels or scales; namely, the site scale, destination scale, regional and national scale, and international scale.

- **Site scale:** A site is a land area within a destination zone that has one or more tourist attractions and is usually controlled by one or more individuals, firms, or government agencies. At this level, planning entails planning attractions, facilities, and services for visitors.
- **Destination scale:** A destination zone may be defined as a geographic area containing a critical mass of development that satisfies traveller objectives and which has scope for establishing tourism links with the community. The destination also includes all locations en route where visitors have to halt for the night.
- **Regional and national scale:** Planning at the national level is essential for better integration. On this scale there are more institutions and stakeholders involved. The planning horizon must encompass a longer time frame.
- **Internationals scale:** For transboundary or cross-border tourism projects or initiatives such as the Great Himalayan Trail, Buddhist Circuits and so on, planning and collaboration on an international level are needed and are imperative for its success.

Box 5.1 shows an example of planning for tourism in Myanmar and Box 5.2 an example of the site planning concept and factors to be included in site analysis.

The Tourism Planning Process

Tourism is one of many activities in a mountain community or region that requires planning and coordination. Planning is the process of identifying objectives and defining methods of achieving them. Mountain tourism planning must be comprehensive and consider all relevant components of tourism. It is also part of overall mountain land-use planning. Comprehensive planning considers all of the tourism resources, organisations, markets, and programmes within a region, including the economic, environmental, social, and institutional aspects of tourism development. Maximum community involvement and involvement of the poor and other socially excluded groups (such as women and mountain minority groups) should be ensured in mountain tourism planning and development as well as decision making. The basic steps involved in tourism development planning are well discussed in tourism literature. Box 5.3 provides 10 key questions as essential steps to planning sustainable tourism.

Box 5.1: Planning Tourism for the Mountains – Valuing the Attraction of Mountains in Myanmar

Mountains often play an important role in tourism. As stated in Chapter 3, mountains are thought to be second in global popularity as tourist destinations. The demand for mountain tourism destinations is growing rapidly. Myanmar has acknowledged the value of its mountains and identified several specific mountain tourism destinations.

Mountain Tourism Destinations Identified

Putao District, Kachin State

Mt. Khakaborazi; Putao District, Kachin State

Mt. Punggan Razi; Putao District, Kachin State

Mt. Madoi Razi Putao District, Kachin State

Mt. Victoria (Nat Ma Taung); Kampet, Chin State

Popa Mountain Resort; Mandalay Division

Main Attractions

Scenic natural beauty snowy trails

Mountaineering and adventure trekking

Unique flora, fauna (unique orchids, rhododendrons, medicinal plants, bird species)

Geological features (mountains, volcanoes)

Sacred landscapes (home of Myanmar Nats, supernatural beings)

Culture and traditions of the indigenous ethnic people of Putao district

Recognising the value and attraction of its mountains, Myanmar has taken a proactive stance towards tourism development and conservation by developing a specific mountain tourism policy.

Source: Ministry of Hotels and Tourism Myanmar 2006



Mt. Khakaborazi

Box 5.2: Site Planning Concept: Site Analysis

Site analysis should include both on-site and off-site factors.

On-site factors include the following:

- Construction elements (legal and physical boundaries, existing buildings, bridges, and other infrastructure including historical, cultural and archaeological sites, trails and transportation, existing land uses, zoning regulations, and health codes)
- Natural resources (topography, gradients and drainage patterns, soil types, water bodies, vegetation type – trees and other plants)
- Aesthetic characteristics (views, features, and spatial patterns)

Off-site factors include the following:

- Surrounding land use
- Stream and drainage sources
- Influence of noise pollution

Box 5.3: Steps to Sustainable Tourism Planning

Steps	Process
What do we want to do?	<ul style="list-style-type: none"> ● Define goals and objectives and understand the place/project context
Who is, could be, or needs to be involved?	<ul style="list-style-type: none"> ● Identify key stakeholder groups and their interests, involve and empower them, and develop effective working relationships
What is known?	<ul style="list-style-type: none"> ● Identify and summarise information available on current and potential tourism markets and determine tourism assets, values, and themes
What makes this region, place, or product special?	<ul style="list-style-type: none"> ● Identify the special value of the region, place, or tourism attraction and recognise their potential
What are the issues?	<ul style="list-style-type: none"> ● Identify and understand key issues affecting the region, place, or product
Analyse issues	<ul style="list-style-type: none"> ● Analyse issues further to clarify and prioritise
Principles or objectives to guide actions	<ul style="list-style-type: none"> ● Develop clear principles or objectives to guide actions and reach agreement in consultation with all key stakeholders
What are your ideas and options?	<ul style="list-style-type: none"> ● Work through ideas and options with key stakeholders and reach agreement on preferred option(s)
How to do it?	<ul style="list-style-type: none"> ● Develop actions to implement ideas, proposals, or preferred options in a clear and logical way ● Develop monitoring and evaluation methods
Statement of directions	<ul style="list-style-type: none"> ● Prepare a statement summarising the outcomes of processes and proposals and identifying key tourism assets, issues, and future action

Source: Australian Government, Department of the Environment and Heritage 2004

Although the planning process varies depending on the types of planning and local conditions, it generally follows the following basic steps:

1. **Study preparation:** The first step involves the preparation of the terms of reference (ToR) for the tourism planning study and the selection of a multidisciplinary team.
2. **Determination of objectives:** The objectives that the tourism development is expected to accomplish should be determined in close coordination with community residents, government authorities, and other relevant key stakeholders. Objectives should be clear, unambiguous, and achievable, balancing the three pillars of sustainability: the economic, environmental, and sociocultural.
3. **Feasibility assessment:** Various surveys and studies are essential to establish an inventory and evaluate existing and potential tourist attractions (and other supply components) on the proposed site. Such surveys should cover many elements related to tourism such as existing tourist arrival patterns and potential tourist markets; existing tourist facilities and services; local infrastructure; socioeconomic, sociocultural, and environmental conditions; and existing government development policies and plans.
4. **Analysis and synthesis:** Analysing and synthesising existing and potential tourism markets (demand) based on existing and future tourism attractions and other tourism products (supply) are needed. The common technique is to first identify the target market (the types and number of tourists that can be attracted). This will provide the basis for projecting needs for accommodation, transportation, and other tourist facilities and services and to assess the likely economic, social, and environmental impacts. Equally important at this stage is to establish the carrying capacity of the area based on an analysis of the major opportunities for and constraints to developing tourism.
5. **Policy and plan formulation:** At this stage, the tourism development policy and plan should be formulated based on the elements that have been surveyed and analysed with due attention to the integration of tourism into the overall development policy and plan of the area. The planner should prepare alternative plans and evaluate how well each of these fulfil the tourism objectives, optimise benefits, minimise negative environmental and sociocultural impacts, and, thus, achieve sustainable development. The environmental impact assessment (EIA) provides a basis for a detailed assessment of the likely impacts of each proposed alternative plan and recommends the suitable alternatives for implementation (see Tool 25, Volume 2). It is important to involve all relevant stakeholders in deciding about the most appropriate policy and plan.
6. **Implementation and monitoring:** Implementation techniques should be identified in the planning process. They may include zoning regulations in view of the established carrying capacity of an area, design criteria or guidelines for site development and tourist facilities, tourism product development, diversification and integration with local production system, and institutional capacity building. Finally, continuous monitoring of tourism and the environment is critical to ensure that development is following the plan and that tourism is bringing the desired results. Management should be flexible enough to take corrective action to reformulate or adjust the plan based on the monitoring results.

Box 5.4 shows the tourism vision from the Master Plan of Himachal Pradesh, India.

Box 5.4: Vision for the Development of Tourism– The Master Plan of Himachal Pradesh, India

Tourism Vision of Himachal Pradesh

- To make tourism the prime engine of economic growth in the state by positioning Himachal Pradesh as a leading global destination by the year 2020
- Increased income from tourism on a sustainable basis
- Care for the natural environment

Elements of the Master Plan

Improved infrastructure and better accessibility

- By road
- By rail
- By air
- Public private partnerships
- Town and country planning and special area development authorities
- Tourist police
- Tourist information centres

Upgrade accommodation

- 4 and 5 star hotels
- De-luxe resorts
- Health and fitness resorts
- Meditation and spiritual centres
- Heritage hotels
- Standardised budget accommodation
- Mountain resorts
- Ecotourism camps

Adventure tourism

- Paragliding
- River rafting
- Trekking
- Mountaineering
- Western Himalayan Mountaineering Institute, Manali
- Skiing/heli skiing
- Mountain cycling

Religious tourism

- Dharamsala–Buddhist capital
- Buddhist circuit
- Naina Devi–Jval Amukhi–Chintpurni–Chamunda–Part of the Shaktipeeths
- Churches
- Sites of Sikh pilgrimage – Rewalsar, Paonta Sahib

Vision 2020

- World class infrastructure (road, rail, air)
- Tourism contribution to state economy of 20-25%
- At least 15-20, 5 star hotels/mountain resorts of international standard
- Set up 50 heritage villages
- Major one-stop destination for adventure tourism in India
- Set up 2-3 major film cities
- Buddhist tourism capital of the world
- Maharana Pratap Sagar Lake – largest ecotourism destination in India
- 100% privatisation of tourism
- Ropeway state of India
- Tourism Development Board

Source: Himachal Tourism 2006

Framework for Monitoring Sustainability of Mountain Tourism

What to monitor and accomplish – the VICE model

The agenda of sustainable mountain tourism (see Chapter 4) can be used as a framework, not only for developing policies for more sustainable mountain tourism, but to monitor progress towards, and impacts on, sustainability. There are two ways in which tourism policy can exert an influence on sustainability:

- By minimising the negative impacts of tourism on society, culture, and the environment
- By maximising tourism's positive and creative contribution to local economies, the conservation of natural and cultural heritage, and the quality of life of hosts and visitors

Attempting to make progress towards the sustainability of mountain tourism can be meaningless without some objective way of assessing whether its underlying principles are being respected. As a central component of the planning and management process, indicators can be used to monitor impacts on visitors, industry, community, and environment (VICE) over time in a constant and consistent manner. The VICE model (Figure 5.2) is useful not only for identifying key groups of stakeholders but also for devising a successful monitoring strategy by identifying how to:

- Welcome, involve, and satisfy visitors
- Achieve a profitable and prosperous industry
- Engage and benefit host communities
- Protect and enhance the local environment

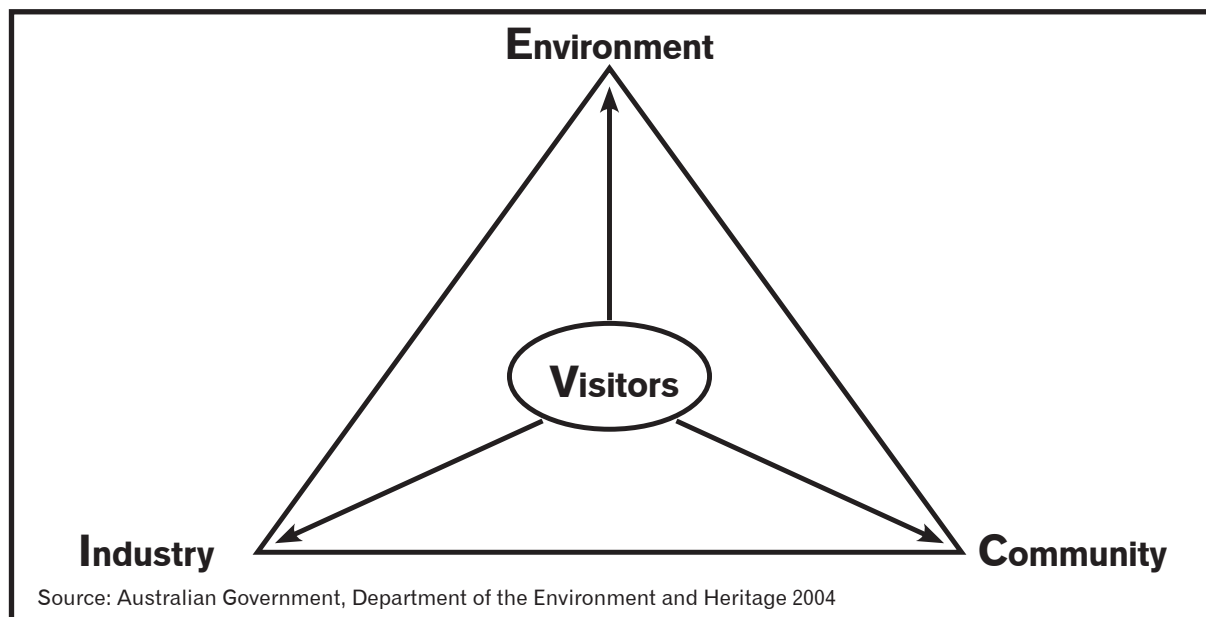

Figure 5.2: VICE model

Monitoring the sustainability of mountain tourism thus involves keeping abreast of the activities, needs, and opinions of key stakeholder groups, which include the following:

- **Visitors:** through site surveys, focus group discussions to check on profiles and levels of satisfaction
- **Industry:** through surveys to check on their economic performance and their perceptions towards tourism impacts
- **Local community:** through household surveys and focus group discussions to check on attitudes towards tourism and concerns about its impacts

- **Environment:** through inventory surveys and carrying capacity assessments (see Volume 1, Chapter 4, and Volume 2, Tool 2)

More information about VICE indicators and monitoring can be found in Volume 2 (Tool 34).

Sustainability indicators and monitoring

Monitoring sustainability involves taking measurements of environmental, social, and economic conditions using selected indicators (see also Chapter 11). A set of performance indicators developed for the VICE model can be used as a check to ensure that the needs of each group of key stakeholders are met. A detailed overview of the sustainability indicators under the VICE model can be found in Volume 2. (Tool 34). A successful example of a model integrating the different aspects of sustainability is given in Box 5.5.

Box 5.5: Integrating Conservation and Development: The ACAP Approach

Traditionally, tourism development models have been spatial and economic. Tourism planning often fails to consider environmental and social issues until well after the economic issues have been dealt with. Accepting the importance of the proper integration of different components in effective tourism planning, the National Trust for Nature Conservation (NTNC) adopted an integrated approach to planning, developing, and managing tourism in the Annapurna Conservation Area (ACA).

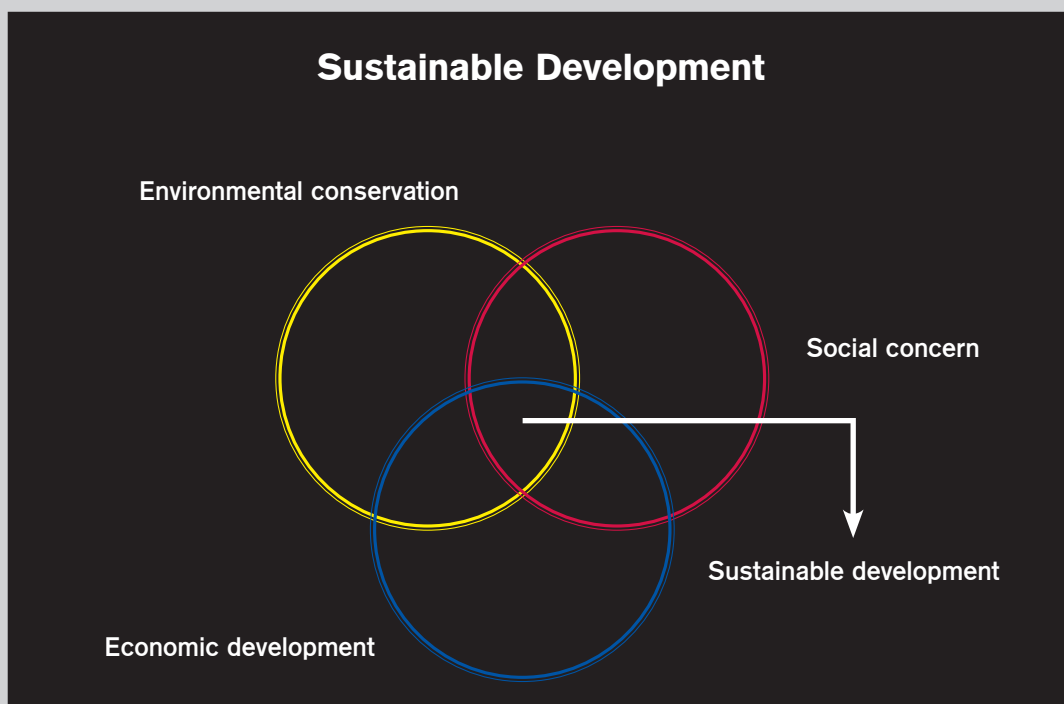

The integrated conservation and development approach in the ACA carefully incorporated all three components of sustainable development. Natural resource conservation is one of the key components of the approach. Natural forest, wildlife, and water resources are conserved through different activities including plantation on degraded land, reducing pressure on forests, reducing disturbance of wildlife habitats, research, and educating major stakeholders. The revenue generated by tourism is reinvested in these activities. Moreover, all the planning, designing, implementation, and management of integrated activities are carried out together with local communities in the ACA. ACA's community-based tourism planning and management model is well known globally.

Source: NTNC 2006

Part 3

Overview of Approaches

Chapter 6

Participatory Planning and Organisation

This chapter covers

- The concept and importance of a participatory process in sustainable mountain tourism planning and development and its link with the project cycle
- Some of the main approaches of the participatory process in sustainable mountain tourism planning and development
- Some important participatory tools: development wheel, participatory resource mapping, seasonal calendar, trend lines, Venn diagram (for detailed descriptions, see Volume 2)

Introduction: The Importance of Participation in Sustainable Mountain Tourism

Local participation, that is participation of local stakeholders, is a key factor in making any sustainable tourism development programme a success. The reason for this is simple: without involving local people in tourism development strategies, tourism projects may be difficult to implement because local people might obstruct or block the development process due to the lack of benefits that will accrue to them. As a result, tourism will fail to realise its full potential to function as a tool or catalyst for the development of local communities and environments, the reason why many are involved in the process in the first place.

Evidence has shown that, with involvement or control in decision making, people tend to work harder to ensure success. Although there is no guarantee that the participatory approach will always ensure success, evidence based on different projects carried out in different countries in the region provides overwhelming support for this approach. Studies conducted by the World Bank in Asia, Africa, and South America (cited in Banskota and Sharma 1998) show that beneficiary participation in their projects contributed significantly to effectiveness. They concluded that

- participation contributes significantly to overall project effectiveness,
- through participation the equality of access to facilities is assured,
- participation fosters individual and community empowerment,
- participation promotes management and organisational skills in the community, and
- participation strengthens local organisations which can then take up new development activities.

Local participation is not a one-time activity or event to ensure a project's success that can be ticked off before a tourism development project starts. Ideally, it should be a process in which all

beneficiaries have an active role in the identification and formulation of problems and opportunities, in the design and implementation of development strategies, and in the monitoring and evaluation of results, as well as the process itself. Participation is, therefore, intrinsically linked to the project cycle, as it incorporates reflection and action and follows all stages of the cycle from analysis, planning, and implementation to monitoring based on which plans can be adapted. There are different levels of participation, varying from simply being a beneficiary, to fully-developed self-realisation in the form of self-mobilisation without the help of any outside institutions. Box 6.1 provides an example of project failure in Nepal due to lack of participation.

Box 6.1: Project Failure due to Lack of Participation

Swayambhu Maha Chaitya, a World Heritage Site, was selected as a pilot 'urban attraction' improvement scheme by the 'Partnership for Quality Tourism' project supported by the UNDP. The surrounding areas of the World Heritage Site lacked hygiene and sanitation facilities and were filled with garbage. There was no effective management in place at the site. The project goal was to establish and test an active, functioning, and self-sustaining urban heritage site management model for possible replication in other areas in Nepal. A massive clean-up campaign was undertaken, toilets were constructed, and a participatory process of institution building was launched.

One year after implementation, successes achieved at the beginning could not be sustained. Participatory institutions and their sustainability were identified as one of the critical reasons for the failure of the project. The first critical failure was that initiatives did not originate from within the community, nor was the community in control of the experimental process. Local people had never been consulted or made aware by their leaders of what this social experiment was about.

On the whole, the lack of local initiation and control limited the transparency of project information to local people, led to a lack of coordination between organisations, and, above all, limited the participation of local people in the decision-making process. Participation did not work, as its foundations were on a wrong footing.

Source: Banskota et al. 1995

It is often easier to think of participation as a continuum rather than discrete types. Keeping this continuum in mind, it is useful to identify broad categories of participation types. A useful typology for distinguishing different levels of participation is given by Pretty et al. (1995). He distinguishes between the following types of participation, building on the level of activity and professionalism:

1. **Passive participation** – Being a beneficiary
2. **Providing information** – Answering questionnaires
3. **Consultation** – People are consulted, experts decide
4. **Participation for material incentives** – People are not only consulted, but also provide resources, e.g., food for work
5. **Functional participation** – Group formation, using fixed objectives
6. **Interactive participation** – Joint analysis, making action plans
7. **Self-mobilisation** – People start themselves without outside institutions

Which level of participation is most appropriate depends on the goal and objective of the programme or project, the wishes and capacity of the groups, and the stage of the project cycle that the activity is in. In tourism, as in other economic development activities, participation occurs in different forms. The broadly recognised categories of participation in tourism are summarised below (Shrestha and Walinga 2003):

- **Participation in sharing economic benefits:** A decision is made about the degree of decision making in the choice of the economic activity that generates the benefit.

- **Participation in planning:** Participants play an important role in the generation of information, its analysis, and subsequent use, i.e., in the learning and planning process. A critical aspect in this participation is assessing options and their economic and conservation feasibility.
- **Participation in implementation and operations:** Tourism requires implementation structures and arrangements to conduct activities. Participants play a key role in implementing activities, setting up institutional arrangements, and in enterprise operations.
- **Participation in decision making and management:** Participants play a key role in the choice, design, and management of tourism, including tourism enterprises, conservation activities, and monitoring and evaluation.

Participatory Approaches in Sustainable Mountain Tourism Development

Over the past three decades, there has been a rapid expansion of new participatory methods, especially in the context of sustainable development. The idea of participation is not without historic antecedents, and while contemporary approaches often focus on issues such as poverty, gender, and social inclusion, they all draw on a considerable legacy of ideals and practical agendas, including action research and adult education. In the wider thrust of development programmes and initiatives, the primary aim of participatory strategies is that local people become active subjects of the development effort, rather than passive recipients. Most community-based tourism development projects are designed and developed using a combination of different techniques, tools, and workshop methods. In this overview, four of the main recent approaches are discussed: social mobilisation (SM), appreciative participatory planning and action (APPA), market analysis and development (MAD), and enterprise support services (ESS). These approaches are for a great part drawn from the toolkit for development practitioners entitled ‘Developing Sustainable Communities’ that was published by ICIMOD for SNV and combine concepts with field-tested participatory learning and action (PLA) tools and games (SNV Nepal 2004).

Social mobilisation

Social mobilisation can be defined as ‘a process of bringing together all feasible and practical inter-sectoral social allies to raise people’s awareness of and demand for a particular development programme, to assist in the delivery of resources and services, and to strengthen community participation for sustainability and self-reliance’ (McKee; cited in SNV Nepal 2004).

Social mobilisation strengthens the capacity of women and men to address their needs in a socially, economically, and ecologically sustainable manner. It intensifies programming with marginalised groups and includes both intended beneficiaries and the broader society, and it combines community participation with advocacy on selected issues.

In Figure 6.1, an example is given of how the different stages of the social mobilisation process can be used or linked to a sustainable tourism development project.

Appreciative participatory planning and action

Many community-based tourism development approaches in the past left local people with the impression that their community is full of problems and needs that require the help of outsiders or support from outside agencies. This created a desire to shift away from problem-oriented methods towards processes that build local strength and generate a sense of hope in the community – precisely the goal of the APPA approach.

The appreciative participatory planning and action process focuses on and identifies the best ‘what is’ to pursue dreams and possibilities of ‘what could be’. It focuses on a community’s achievements rather than its problems and seeks to foster inspiration at the grass-roots level. It involves collaborative

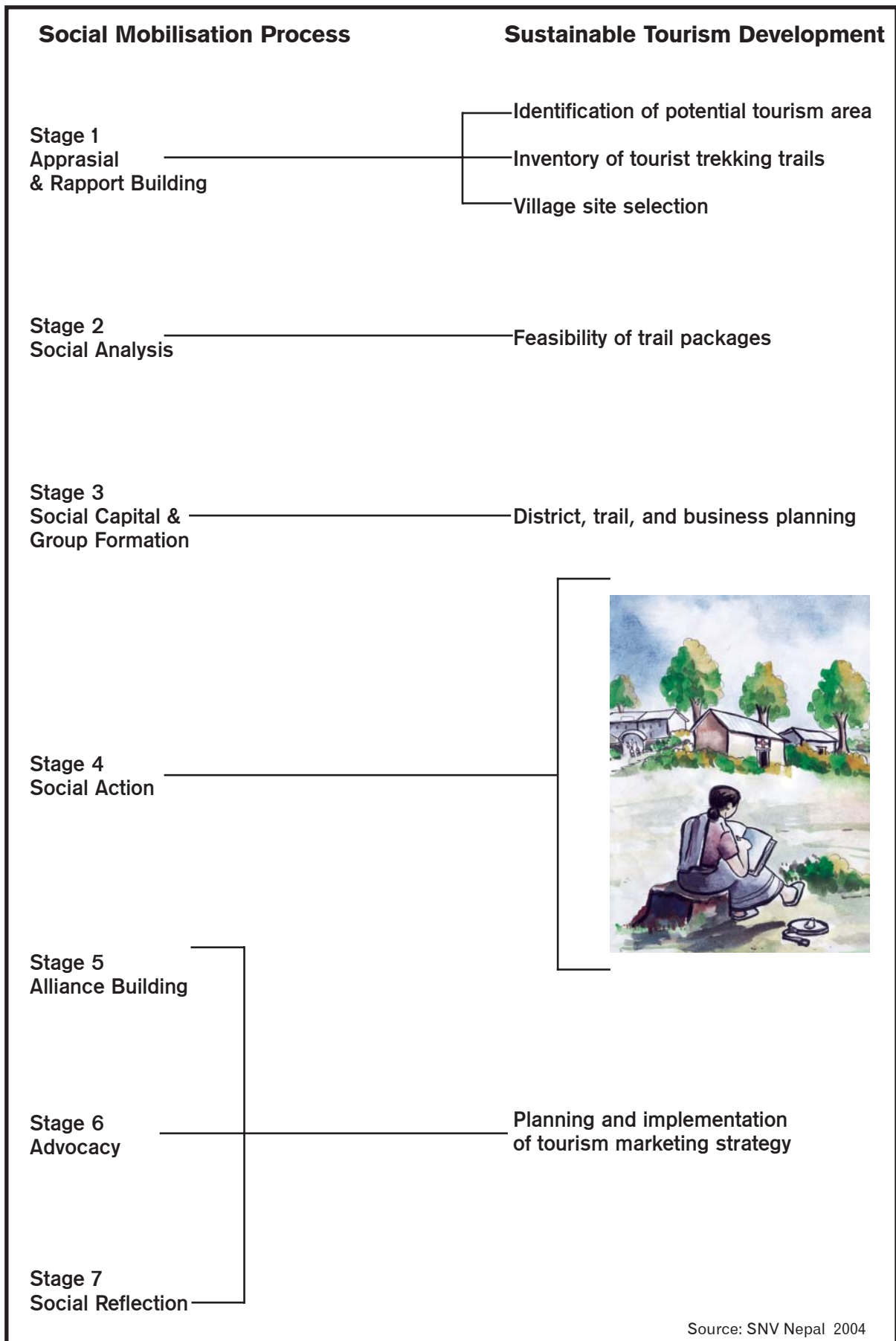

Source: SNV Nepal 2004

Figure 6.1: Linking social mobilisation with sustainable tourism development

enquiry based on interviews and affirmative questioning. Although it is a relatively new approach, it builds upon the practice of PRA (participatory rural or rapid appraisal), PLA (participatory learning and action), and group dynamic disciplines that have influenced rural development over the past 20 years. APPA's success has been ascribed to the following aspects:

- It is true to human nature.
- It allows room for emotional responses.
- It allows room for intellectual analysis.
- It allows room for imagination, as well as rational thought.

The APPA process consists of five stages: discovery, dream, direction, design, and delivery. In the **discovery** phase, participants identify their strengths and skills as individuals and recognise assets and opportunities in their community. The emphasis in this stage is on successes that can be strengthened, managed, and marketed to generate local benefits and that also support the conservation of resources. The aim is to inspire self-pride and local initiative, rather than nurturing dependence on outside resources. Box 6.2 illustrates the discovery stage at Yuksam in Sikkim, India.

Box 6.2: The Discovery Stage in Yuksam, Sikkim (India)

APPA was successfully used to guide a community-based planning process by The Mountain Institute (TMI) in Sikkim, India. The opportunity identified was to promote Yuksam-based activities as a way of increasing local incomes from tourism and of generating incentives to conserve the resources on which such incomes depend. In the discovery phase, villagers identified, mapped, and valued the assets and strengths of Yuksam Village in terms of their tourist potential.

- Lots of greenery
- Community unity seen in actions to help others
- Meeting tourists from many different countries
- Fresh air
- Dense forests
- Yuksam was the first capital of Sikkim
- Historic importance of Yuksam

Source: TMI 2000

The discovery stage is followed by the **dream** stage. In this stage, participants collectively visualise how they would like to see their community develop in the future, how they can benefit from a project, and how they as a community can achieve the dream by building upon the strengths, skills, assets, and opportunities identified in the discovery stage. For many mountain communities, a vision of their community in 10 years is appropriate, whereas longer periods (20 to 30 years) may work for organisations or businesses attuned to long-term planning. The dream stage defines what the community sees as the desirable form and characteristics of pro-poor sustainable tourism development and records a visual image of how these developments can be managed in the future. Box 6.3 illustrates the dream phase for Yuksam.

The dream is followed by **direction**. In this stage a process of dialogue, consensus, and further enquiry is central. Direction clarifies and clusters the dreams identified in the dream stage into potential activities that can be developed. This helps to eliminate pro-poor sustainable tourism development activities and other community development needs that do not directly meet pro-poor sustainable development objectives. In short, direction assesses dreams against objectives and eliminates ideas that do not meet the objectives; directs participants to the most viable ideas; and helps participants to focus their energy, efforts, and resources on viable ideas.

Box 6.3: The Dream of Yuksam, Sikkim (India)

After having discovered the assets and strength of their village, villagers from Yuksam were asked how they envision their village in 10 years. They envisioned that in 10 years they would have the following:

- More forest cover
- More tourists in Yuksam
- No litter in Yuksam and along the trails
- Local conservation groups or NGOs
- More income from tourism
- Yuksam as a little Switzerland

Source: TMI 2000

After a direction is found, the **design** of a tourism project can take place. In this phase, areas are identified that require further investigation, making use of the participatory learning and action tools (see Volume 2) to help collect data to address key gaps in information. Key factors that will form the framework for deciding and prioritising pro-poor sustainable tourism development strategies for the community are discussed. Based on the final assessment, facilitators and participants can work towards developing a strategy and formulating an action plan(s), as well as monitoring and evaluating these plans.

The design phase is followed by **delivery**. Delivery is the 'action' part of APPA, the fifth (but not final) step in the 5-D cycle. It is about making dreams come true; the implementation of action plans so that communities develop and manage community-based projects. It harnesses the positive energy and confidence that is built up during discovery, dream, direction, and design into action, i.e., 'what works'. Box 6.4 gives an illustration of how the dream of Yuksam was translated into a tourism vision and community plan, and how these were put into practice by the villagers in the area.

Box 6.4: Materialising the Dream of Yuksam, Sikkim (India): Direction, Design and Delivery

After directing their dream towards the most feasible goals, the villagers of Yuksam jointly developed a vision and community plan. A preliminary report designed by participants included the following:

- A list of their environmental and community attributes
- Ecotourism resource maps
- Local stories about sites and history
- Maps and analyses about the availability and use of forest resources
- Socioeconomic analyses of tourism benefits

After the design of their joint vision and plan, the villagers were empowered and their efforts adjusted and sustained through concrete activities (the delivery). These included:

- Village beautification activities, e.g., planting of native tree species and clean-up campaigns
- Training courses for lodge operators and naturalist guides
- Collection of materials to be used for promotional brochures about Yuksam and its attractions

In addition to these activities, 28 village members organised their own clean-up campaign for the major trekking route, generating a small amount of funds for further activities by recycling bottles and tins. Furthermore, the villagers of Yuksam decided to form a community-based NGO to work on conservation and tourism issues – an NGO that has been active ever since.

Source: TMI 2000

The use of APPA for rural tourism planning is further illustrated in Box 6.5 using the example of the Tourism for Poverty Alleviation Programme (TRPAP) in Nepal. The five stages of the APPA process follow the project cycle stages of analysis, action, and evaluation, leading to the rediscovery of assets. In this way the APPA cycle can be continued over and over again, to assess and reassess, to direct and redirect, as an evaluation tool, and to change the course of action. The use of APPA as a re-evaluation tool by TRPAP is shown in Box 6.6.

Box 6.5: Conducting APPAs for Rural Tourism Planning

With the main goal of alleviating poverty through development of rural tourism in Nepal, TRPAP extensively used APPA exercises to prepare community-based rural sustainable tourism plans in 48 selected village development committees (VDCs) in Nepal. In the first stage of the implementation process, social mobilisers were hired. These social mobilisers were trained on the process and methods of APPA, as well as the Tourism and Environment Awareness Programme. The trained social mobilisers started building rapport with communities in the assigned VDCs, informed them about the programme, and formed community-based organisations (CBO) at the settlement level.

Once the members of the CBOs were aware of the benefits and impacts of tourism through Tourism and Environment Awareness Programme, social mobilisers facilitated the communities to prepare a five-year tourism plan using the APPA method. During the APPA planning exercise, participants worked on the 5-D cycle in detail. At least two social mobilisers were involved in conducting one APPA planning exercise. Each APPA was a three-day long tourism planning process in which 20 to 30 community members participated. Efforts were made to ensure that the participants of the APPA planning exercise consisted of an equal number of men and women from various walks of life from the settlement or village with representation from specially targeted, socially-excluded groups.

On the last day of the APPA, the participants worked on the dream, direction, and design part of the 5-D cycle. Using these techniques, they prepared a five-year community tourism plan. The participants dreamed of how they would like to see their village in the next five years, and planned by, when, and how they were going to achieve their dreams. They prioritised their dreams (planned activities) as per their necessity. The programme gave priority to those activities that were listed in the APPA report. In some reports, activities were listed that were beyond the programme's intended intervention such as the construction of health posts or veterinary clinics. In those cases, the social mobilisers helped the community to contact the right people in the district headquarters for support to construct such centres in their villages. Thus, the APPA report became the main community document for the development of rural tourism in the villages.

Source: Kayastha 2006

Box 6.6: Re-APPA as an Evaluation Tool

In the final year of the project cycle, TRPAP carried out a 're-APPA' in all those villages or settlements where APPA exercises were done at the beginning of the programme. The main objective of the re-APPA was to see what changes had happened since the programme started working with the community by comparing the various PRA tools used during APPA and re-APPA exercises. At the same time, the re-APPA also reassessed to what extent dreams envisioned in the APPA exercises were actually delivered.

The comparison between APPA and re-APPA reports clearly showed the outputs and impacts of the programme in the village, especially through the development wheel and well-being ranking. Even villagers who could not read could see the changes brought by the programme's intervention through the development wheel.

The re-APPA involved the same people involved in the initial APPA. The outcomes of the re-APPA, such as the development wheel and Community-Based Tourism Plan, reflect the consent of the community to the success of the programme's interventions.

Source: Kayastha 2006

Market analysis and development

In order for tourism to be pro-poor and for local people to truly benefit from tourism development in their area, a market-oriented approach is needed. In the past, many tourism development projects have been limited to a community-based approach, i.e., mobilising communities and putting all their efforts into building their capacities. Such projects, however, did not take into account the economic viability of the envisioned projects, often leaving communities disappointed because the benefits expected did not reach their homes and lead to actual improvements in their lives.

Most of the pro-poor sustainable tourism initiatives are struggling to find the right balance between tourism product and market development (support for the private sector), community development and participatory planning, and supporting the development of an enabling environment. This triangulation is needed to achieve an established link between the local production and service system, and the tourists and tour operators (e.g., through policy development and implementation, institutional development, and the creation of public-private partnerships).

Market analysis and development (MAD) differs from conventional business and enterprise planning, as it assesses enterprises holistically, taking into account environmental, economic, social, and technological factors in the development of enterprises, rather than just their commercial aspects. Using a three-stage approach of assessment, analysis, and action, MAD again follows the project cycle approach, similar to the approaches discussed above. In a tourism context, MAD is an excellent tool for pro-poor sustainable tourism development as it develops tourism enterprises that provide income benefits to entrepreneurs, while explicitly focusing on minimising the negative impacts on the natural and cultural resource base on which the tourism industry depends. On the other hand, the MAD approach may not always be successful in reaching the most underserved groups in the tourism industry.

One of the main criticisms of the MAD approach is that a too strict interpretation of the approach makes it difficult to reach underserved groups such as really small micro enterprises (in the informal sector), women entrepreneurs, and remote rural enterprises. Different strategies have been proposed to achieve economies of scale and reach underserved groups, e.g., the formation of clusters or networks, by cross-subsidising less profitable activities or low-income groups from more profitable or high-income groups, or by treating specific underserved groups such as women entrepreneurs as market niches. Underserved groups often have different demands for services than other micro and small enterprises (MSEs) because they face different constraints. In some cases, they do not have access to services because suppliers have not viewed these groups as viable market niches. Convincing suppliers that these groups are a viable and growing market may be an important part of a tourism market development programme. When programmes and suppliers understand these demands, they can develop service products that appeal specifically to MSEs. Offering appropriate products will help to stimulate demand from underserved groups of MSEs. For example, the business tours developed for free independent travellers (FITs) in East Africa were popular with women entrepreneurs because they viewed the security of travelling in groups as an important service feature. Nevertheless, all these strategies cannot avoid that there is an implicit or explicit selection mechanism at work that discriminates against underprivileged groups (SNV 2003a).

Strengthening the capacity of a range of profitable tourism business development service providers to offer demand-driven, affordable, and high-impact services to a large number of tourism MSEs could be a useful tool to overcome these limitations (see Volume 2, Tool 19).

Enterprise support services

Entrepreneurs and potential entrepreneurs often do not have a clear overview of opportunities and constraints presented by tourism development in their tourism destination. There is a limited understanding of tourist needs for certain products and services (the market). In many places this results in limited product diversification (even lodges or hotels in a certain area look similar). More

awareness of tourist needs and demands is necessary. Innovation or creativity in developing tourism products and activities needs to be supported (based on market analysis and development) (SNV 2003b).

Enterprises support services (ESS) assist entrepreneurs and business groups to improve their enterprises. ESS builds upon and combines the latest insights and techniques about enterprise development and incorporates several tools to strengthen institutional and organisational development, such as institutional development and organisational strengthening (IDOS) and the integrated organisational model (IOM) (described in Chapter 13 and Volume 2, Tool 10).

Following the 'Triple-A' approach of analysis (collection of tourism-related information at various levels), assessment (identification of strategic options and strategies for tourism development), and action (gaining insight into implementation), ESS is also a form of project cycle. This cycle can be linked to other cycles as it can support the process of MAD and can use the techniques of social mobilisation and APPA to reorient participants in the tourism process and help to strengthen their capacity as groups and stakeholders within the tourism industry. In Figure 6.2 these (potential) linkages are illustrated graphically.

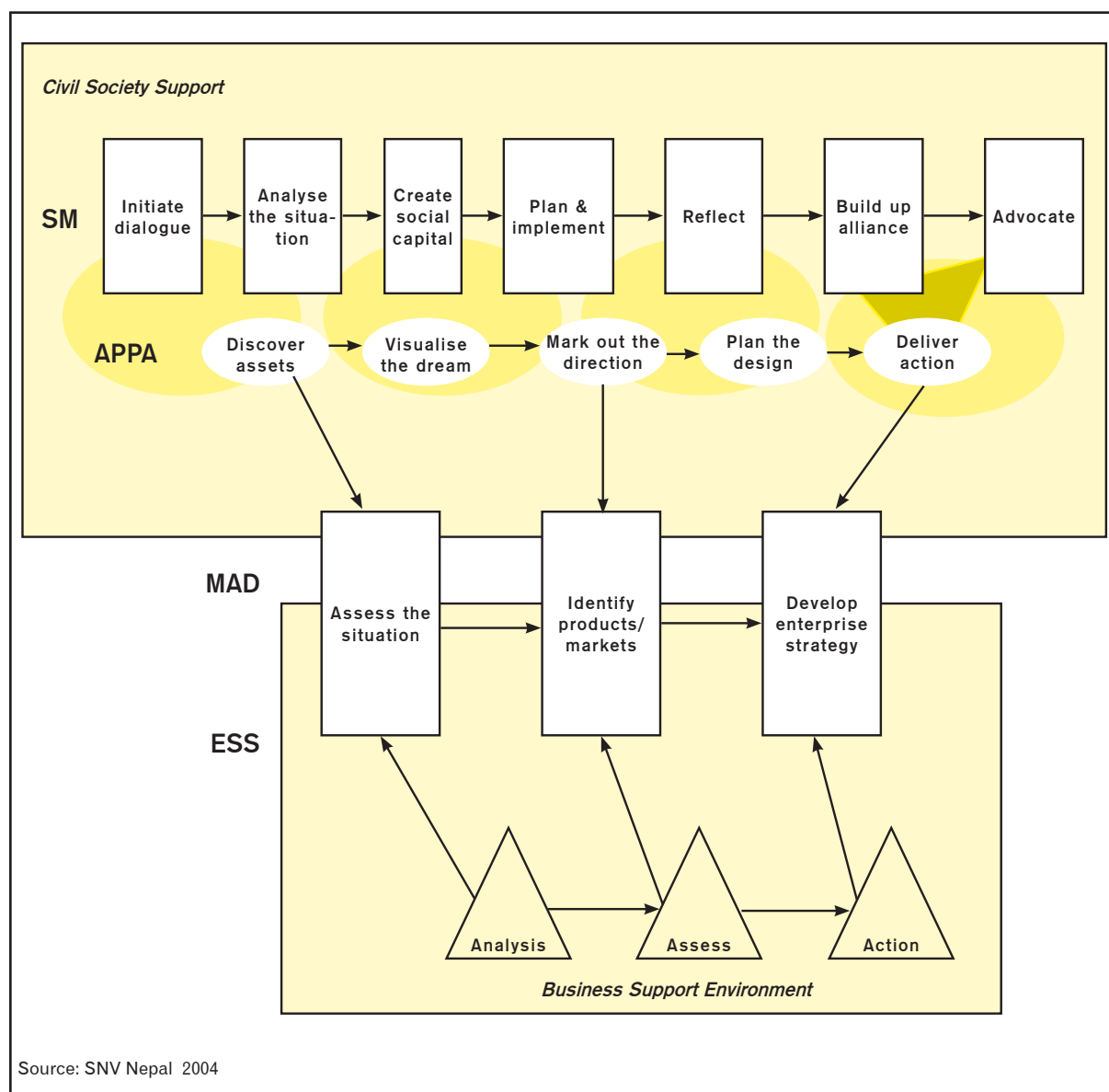

Source: SNV Nepal 2004

Figure 6.2: Linking enterprise support services with other participatory approaches

Participatory Planning and Organisation Tools

In each approach, different participatory learning and action (PLA) tools can be used. Some of the tools have already been introduced briefly above such as the IDOS method and the IOM (explained in more detail in Chapter 13). Some other examples of important PLA tools that are generally used in sustainable tourism planning and development are:

- development wheel,
- participatory resource mapping,
- seasonal calendar,
- daily calendar,
- trend line, and
- Venn diagram.

Development wheel

The development wheel (Figure 6.3) is a tool to assess the situation of the community and is used to measure the progress and impact of a programme.

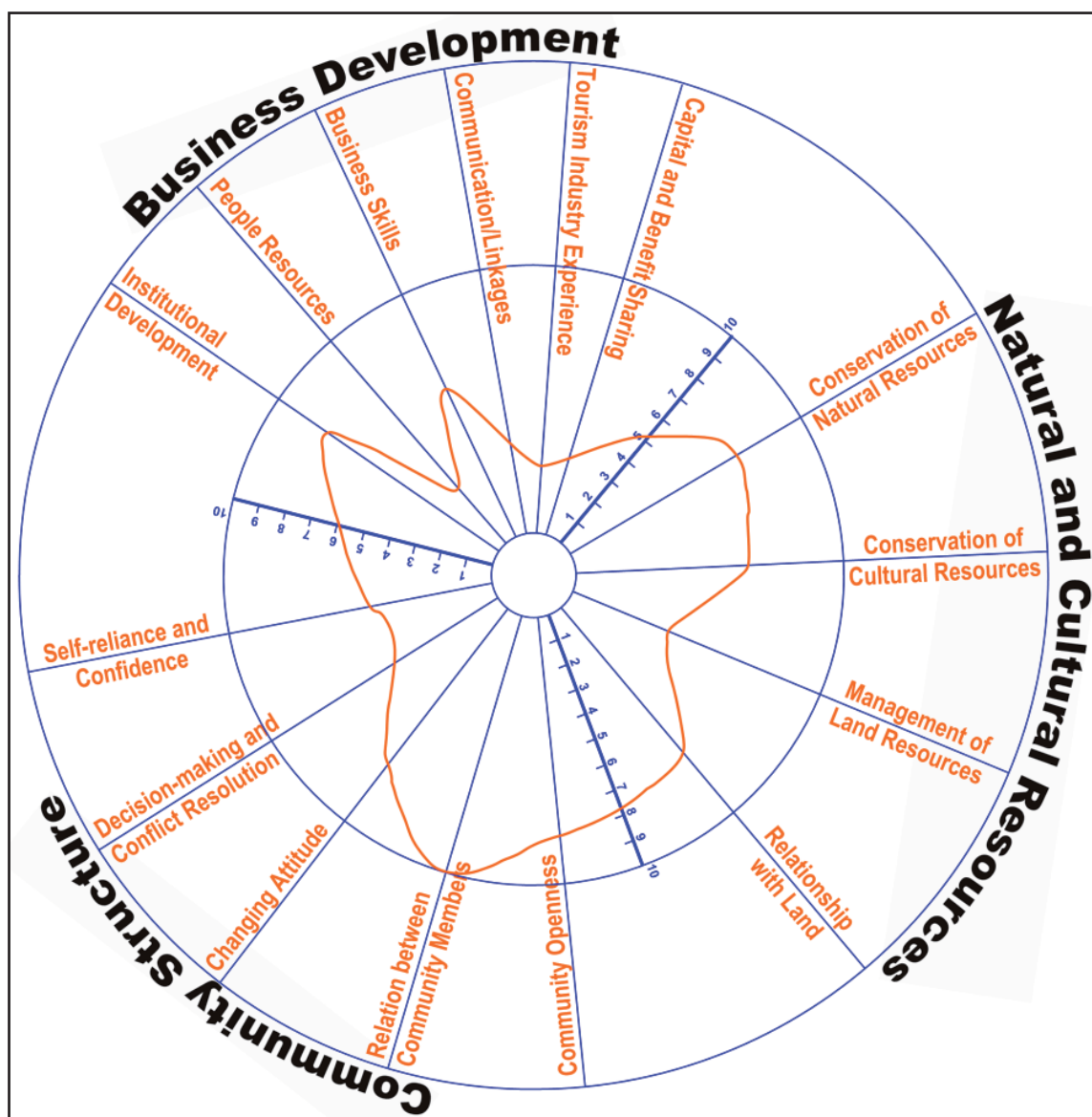

Figure 6.3: The development wheel

The development wheel has three specific components, each of them with their own set of indicators and sub-indicators:

- Community structure
- Business development
- Natural and cultural resources

Box 6.7 shows an example of how this tool was used in the TRPAP programme in Nepal. A detailed description of the different components of the development wheel can be found in Volume 2 (see Tool 24).

Box 6.7: Using the Development Wheel in TRPAP

The Tourism for Rural Poverty Alleviation Programme in Nepal used the development wheel during the APPA process. On the first day of the APPA, the participants worked on the discovery part of the 5-D cycle, using various participatory rural appraisal (PRA) tools. The participants were divided into four to five groups, and each group was allocated a specific time to conduct a specific PRA exercise (tool), such as community resource mapping, seasonal calendar, daily calendar, well-being ranking, access and control, trend line, Venn diagram, historical time-line, and inter-institutional relations. After the groups had done their assignment, they got together and shared their findings. Comments and suggestions from group members were incorporated, after which the participatory tools were finalised and passed. On the second day of the APPA, an exercise on the development wheel was carried out to measure the progress and impacts of the programme based on specific indicators and sub-indicators. After extensive consultation with experts and field staff and after several pilot tests, TRPAP had set five indicators and 20 sub-indicators for community structure, four indicators and 23 sub-indicators for business development, and four indicators and 20 sub-indicators for natural and cultural resources.

Before using the development wheel, the social mobiliser gave a brief introduction about the tool to the participants and explained to them how to work with the tools. Then the participants were divided into three groups. Each group was assigned to work on one of the three components of the development wheel. The groups had to give scores to each sub-indicator ranging from none (0), some (2.5), half (5), most (7.5), and all (10). If different participants in the group gave different scores to the same sub-indicator they were asked to justify their scores and convince the rest of the participants. After discussing with each other, the group unanimously agreed to give one score. The score for each indicator is calculated by taking the average score of its sub-indicators. Thus, each group drew part of the development wheel and shared it with the rest of the group. The group once again commented on the wheel and suggested some corrections with justifications. With the consent of all the participants, the development wheel was then completed. This gave the community a base from which to directly judge the impacts and progress of the programme.

Source: Kayastha 2006

Participatory resource mapping

Resource mapping assists a community or group to:

- understand how women and men see their resources and how these differ from outsiders' views (perception, reports, formal surveys, and so forth);
- draw up a map of the perceived resource situation of the community;
- analyse the steps or process in utilising available natural and cultural resources; and
- analyse the problems and (market) opportunities in relation to natural and cultural resources.

Figure 6.4 shows a participatory resource map being drawn by participants from TRPAP, Nepal. More details are given in Volume 2 (see Tool 13).

Seasonal calendar

The main objective of a seasonal calendar is to demonstrate ways to explore the changes during the year, generate information about seasonal trends, and identify periods of particular stress and vulnerability. Sheets of paper can be used to make a seasonal calendar, but it can also be made with locally-available materials such as stones, seeds, beans, or sketches on the ground (depending on where the exercise is being conducted). Combining all seasonal patterns into one diagram can help identify periods of particular stress (e.g., harvest seasons, periods of drought, or food shortage), during which tourist arrivals may not be desirable. More details and examples of calendars can be found in Volume 2 (see Tool 14). Figure 6.5 shows TRPAP participants putting together a seasonal calendar.



Source: TRPAP 2006

Figure 6.4: Participatory resource map



Source: TRPAP 2006

Figure 6.5: Seasonal calendar

Daily calendar

Going into more detail, a daily calendar helps to understand how local people spend their day doing different activities, i.e., how time is divided for different household chores. A daily activity chart helps to make a comparison of the daily activities of different groups of people like men, women, children, and elderly people at different times of the year. As with other diagrammatic tools, participants should select whatever materials they feel comfortable using – not necessarily a pen and paper. A balanced representation of key informants and gender is necessary to generate discussion about the various activities that local people do.

Trend lines

Trend lines are made to analyse the relationship between historical and current trends in selected environmental, cultural, socioeconomic, and market conditions, identifying opportunities and designing community-based tourism products using historical trend lines as an analytical tool. In this case, a trend line represents a time-line of the impacts and benefits of community-based tourism as a result of the implementation of action plans. Future trend lines can also be used as a monitoring, planning, and reporting tool to measure progress in achieving the impacts and benefits of community-based tourism. More details are given in Volume 2 (Tool 33).

Venn diagram

A Venn diagram shows which institutions are working together on community-based tourism development. It identifies community organisations and institutions and their roles and linkages to community-based tourism. It reveals important linkages and constraints in participants' own institutions or organisations according to the perceptions of different groups of participants. Venn diagrams give a visual representation of different groups and organisations within a community and their relationships and importance in decision making, which is useful for participants with poor literacy skills. The use of Venn diagrams can be illuminating as it may bring certain aspects of institutions and the role they play to the forefront for the first time. Examples and detailed steps can be found in Volume 2 (see Tool 17).

All these tools and other tools that are relevant in sustainable tourism planning, such as wealth ranking (Tool 18), pair-wise and matrix ranking (Tool 11), trend lines (Tool 33), semi-structured interviews (Tool 22), and brainstorming (Tool 1), are explained in more detail in Volume 2. Again, the uses and effectiveness of PLA tools are highly correlated with the project cycle, and different tools can be used for different parts of the cycle process. Which tool to use and how long to allocate for each tool mainly depends on the types of questions that need to be answered in the context of each situation. Different tools and stages can be combined, used as a whole, in parts, or separately, all depending on the local context in which one is working, i.e., the situation of the area, the nature of the groups, and the overall economic and political context of the tourism programme.

Multi-Stakeholder Collaboration

This chapter covers

- The role and functioning of different types of collaboration in sustainable mountain tourism
- The lessons and principles of multi-stakeholder collaboration and factors for successful collaboration within a sustainable mountain tourism context
- The functioning of multi-stakeholder collaboration processes in sustainable mountain tourism

Introduction: The Need for Multi-Stakeholder Collaboration

The sustainable mountain tourism sector is complex, multi-faceted, and embraces a wide variety of stakeholders from the public and private sectors. These actors include local communities, a number of government agencies and departments (local and national), INGOs, NGOs, banks and donor agencies, business associations, accommodation and transport providers, restaurants, retail outlets, journalists, guidebook writers, tourists, and tour agents (at the local, national, and international levels). To get these different stakeholders working towards common goals and to achieve the best results in sustainable mountain tourism, collaboration is needed. Stakeholder collaboration stimulates the active involvement of all parties involved. It helps to create common understanding and encourages local ownership of projects.

Multi-stakeholder collaboration in sustainable mountain tourism can help to promote poverty reduction. This chapter identifies the different types of collaboration processes. It draws on a recent study of UNWTO/SNV Asia on multi-stakeholder approaches in pro-poor sustainable tourism (Buysrogge 2006, unpublished). Collaboration is found at different levels (national, provincial or district, and village levels) to coordinate and promote the interests of the tourism sector and its stakeholders. Many of the experiences with multi-stakeholder collaboration in tourism have been positive. To have a greater impact on poverty reduction, however, a greater understanding is needed of what is happening between stakeholders at micro, meso, and macro levels in different countries.

Multi-Stakeholder Processes in Sustainable Mountain Tourism

As stated before, sustainable mountain tourism is complex, involving many different stakeholders at different levels. Achieving sustainable mountain tourism is an ongoing process. Collaboration is necessary to work towards common goals and to get better results in reducing poverty.

A general term for all different kinds of interactive processes, between multitudes of different actors, is multi-stakeholder processes (MSPs). MSPs are participatory methods aimed at involving stakeholders at different levels in processes of planning and preparation of, for example, sustainable mountain tourism development. Multi-stakeholder processes can help to coordinate activities, pursue

programmes of common interest, and facilitate regular meetings to exchange information. The main characteristics of multi-stakeholder processes can be summarised as follows (Woodhill 2005):

- Dealing with a clearly bounded context and set of problems
- Involving an explicitly defined and evolving set of stakeholders with common (but often conflicting) interests
- Having an agreed, clear, yet dynamic process and timeframe
- Guided by negotiated and understood rules of interaction and cooperation
- Involving stakeholders in learning processes (not just negotiation)
- Dealing consciously with power and conflict among stakeholders and sectors
- Working across different sectors and scales
- Aiming for a balance between bottom-up and top-down approaches
- Aiming to contribute to effective institutional change

Reasons for collaboration

There is a growing awareness of the benefits of cooperation and partnerships in the tourism sector. Various authors have emphasised the added value of collaboration and it is acknowledged that, often, much more can be achieved by working in partnership. Collaboration between various stakeholders does allow for more successful tourism planning, management, marketing, product development, training, and education. Multi-stakeholder processes and partnerships ensure consistency within a framework and act as an effective agent for planning, management, problem solving, and change; and, therefore, enhance rather than reduce the competitive advantage of the tourism product. Public-private partnerships, for example, represent a pooling of knowledge, expertise, capital, and other resources from various stakeholders.

The motivation of individuals or organisations to collaborate varies. In general, people collaborate simply because they are better off collaborating than not. Expected benefits are often the motivation behind an actor's collaboration or participation in a multi-stakeholder process. Benefits can be financial or material, like, for example, profit or working space, or more intangible like image, or knowledge development.

Other reasons to collaborate are the inability to act alone, lack of resources or capital, the complexity of the situation, the need for innovation and efficiency, or ethical and normative reasons. Important to note is the added value of synergy, i.e., being able to develop a product with characteristics that would not have been available without a public-private partnership. In sustainable mountain tourism, one important reason to collaborate is to share knowledge and experiences in poverty reduction through tourism.

Multi-stakeholder collaboration provides many possibilities. Contact (formal and informal) presents an opportunity for dialogue between stakeholders, allowing them to share experiences and methods. Through collaboration, actors can have closer relations with other (key) actors and learning about each other is facilitated. Actors can use the resources of others, whether this is expertise, money, or connections. A group of stakeholders has more bargaining power.

Besides sharing information, sharing experiences, and lessons, collaboration bodies can act as implementing agencies or be used for product development (linking up the resources of actors to develop products), and even for global marketing, putting countries and areas on the map as sustainable mountain tourism destinations.

Factors in successful collaboration

Multi-stakeholder collaboration bodies vary in their effectiveness. Some are successful in their operation, others less so. Although there is no blueprint for collaboration, some general remarks

can be made about factors critical to the successful functioning of multi-stakeholder processes. The following are important factors in collaboration: process design; internal organisation, participation, involvement and commitment; facilitation of the process; and the context.

Process design

The design of a multi-stakeholder collaboration process is important to get good results. For a successful multi-stakeholder collaboration an interactive process design is crucial. Openness, content, safety, and progress are all crucial elements between stakeholders in the collaboration.

Internal organisation

In addition to a good design, the internal organisation of the stakeholder process is also important. As decision making in a multi-stakeholder process is not simple, dividing responsibilities and splitting a project up into sections reduces the complexity of the decision-making process. The following four factors can be useful in assessing the degree of a successful internal organisation:

- Initiation (who sets the terms of reference and agenda?)
- Inclusiveness (representation, accountability, openness, and involvement in decision making)
- Influence (delegation of authority in decision making)
- Information (circulation)

Participation, involvement, and commitment

The internal organisation should emphasise the participation, involvement, and commitment of the stakeholders involved in the multi-stakeholder process. Stakeholders should be able to identify with the process. The strong commitment of high level and qualified public officials and private sector managers with the necessary authority and capacity to reach compromises is also crucial. A process involving stakeholders that possess resources like expertise, information, and contacts will have more chance of operating successfully. These parties will have valuable (grass roots') support and/or a shared ideology and be capable of taking strategic positions and using their influence. Facilitative support (economic cultural capital) and leadership qualities (sociocultural capital) are also important preconditions for fruitful cooperation and collaboration.

Context

It should be mentioned that the context in which the collaboration occurs is important. External issues influence the functioning of any collaboration process. Factors related to the institutional (policy, legal, funding, and cultural) context may affect a multi-stakeholder process and must be carefully considered. Power relations (political, economic, and social) also influence the outcome of the collaboration process. Some stakeholders may coerce others; stakeholders with less power may be excluded from the process or may have little influence. An example of multi-stakeholder collaboration in the tourism context of Nepal is given in Box 7.1.

There is no one single formula for public-private cooperation. However, UNWTO (2000) has made a similar list of factors contributing to the successful functioning of multi-stakeholder processes in tourism:

- The need for a balanced structure (internal organisation) within the partnership with clear roles and responsibilities for all partners
- Shared leadership between the public and private sector with well-defined, shared goals, realistic expectations, and the identification of benefits for each partner
- A flexible approach on the part of all partners, combined with a willingness to understand each other's needs and to contribute to shared resources

Box 7.1: Multi-Stakeholder Collaboration and Institutional Development in TRPAP

In order to make rural tourism a continuous process of development, TRPAP has formed different community organisations (COs), entrepreneurial groups called functional groups (FGs), and sustainable tourism development committees (STDCs) at the grass roots' level. Where COs already existed, the programme works with existing COs. In national park areas, the programme has recognised buffer zone users' groups (BZUGs) at the village level and buffer zone users' committees (BZUCs) at the VDC level, considered equivalent to COs and STDCs respectively.

TRPAP has established sustainable tourism development sections (STDSs) in all programme districts which look after all aspects of tourism development at the district level, backstop grass-roots organisations, and establish linkages at the central level for forward linkages. Tourism management units (TMUs) are established in national parks to coordinate tourism activities between district development committees (DDCs) and national parks.

At the macro level, a sustainable tourism development unit has been established within the Nepal Tourism Board to strengthen forward and backward linkages. The sustainable tourism development unit will take over TRPAP's activities once TRPAP is phased out.

The Department of National Parks and Wildlife Conservation (DNPWC) has designated a focal person to coordinate TMUs, STDSs, and Sustainable Tourism Development Units to ensure environmentally friendly tourism development in protected areas. All these institutions are legally binding entities and are permanent structures at different levels.

TRPAP does not plan activities for communities. It only facilitates the planning process each year at the local level through its COs, FGs, and STDCs. Once the plan for the upcoming year is developed at the grass roots' level, the communities send their plan to the districts who thoroughly review whether or not the proposed activities match the tourism development and planned actions in the settlement-level APPA reports. After removal of non-tourism activities, the final district-level annual plan is sent to the Programme Management Unit (PMU) at the centre. The TRPAP central team again thoroughly reviews the district plan, makes necessary corrections, and forwards it to the ministry concerned and to UNDP for final approval.

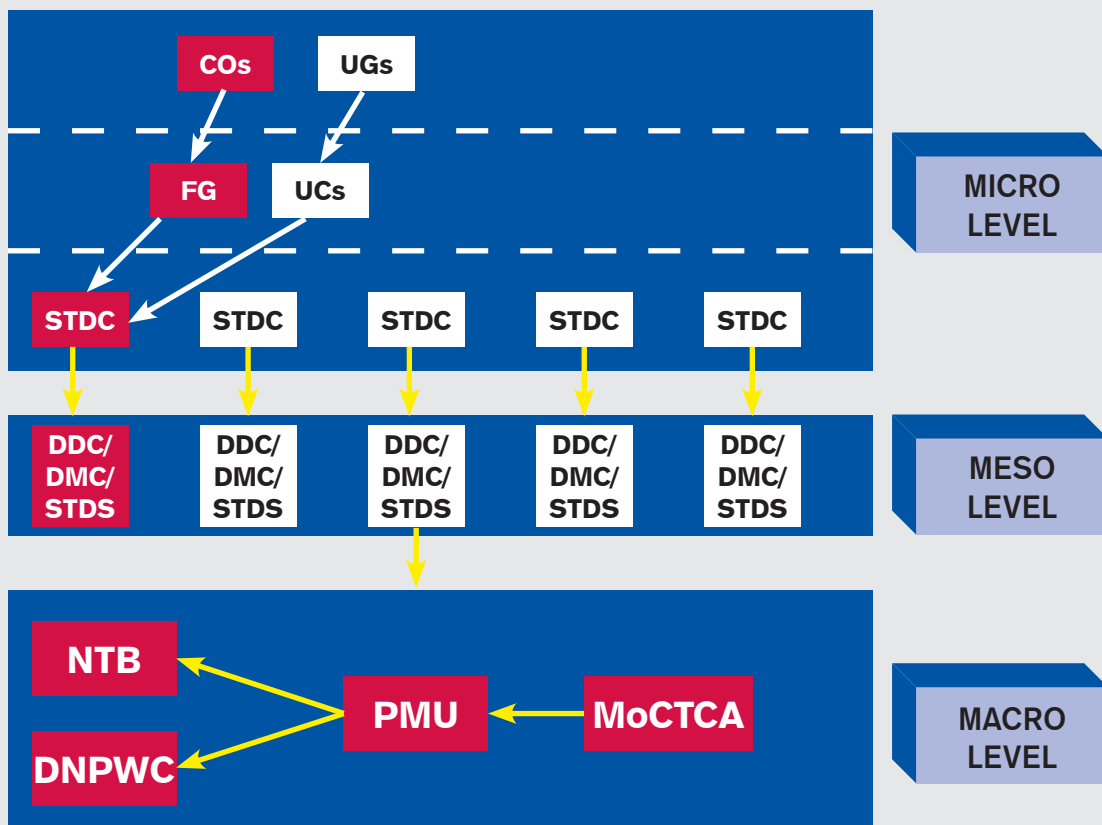

Source: TRPAP 2006

- An understanding between all partners that tourism development must be sustainable economically, socially, and environmentally
- A long-term commitment combining a strategic vision and plan with shorter-term goals and measurable initiatives
- Good communication between partners and from partners to all other stakeholders

Box 7.2 shows an example of successful stakeholder collaboration in Bhutan.

Box 7.2: Successful Stakeholder Collaboration in Bhutan

The Nabji-Korphu trail for trekking and community tourism in Bhutan, is a trail planned and managed by the communities along the trail.

To develop this trail as a new tourism product in Bhutan, all the stakeholders in the tourism industry got together and discussed their roles in the tourism development process and decided what they would like the end product to look like.

They allocated the following roles and responsibilities to stakeholders:

- Department of Tourism (DoT) – monitor the overall project activities
- Association of Bhutanese Tour Operators (ABTO) – organise, monitor, and keep account of the budget and prepare an interim report
- Nature Conservation Division – assist Jigme Singye Wangchuk National Park in the project
- Jigme Singye Wangchuk National Park – monitor project activities during implementation
- Netherlands Development Organisation (SNV) – technical assistance
- Communities (Nimshong, Nabji, Korphu, Kubdra/Phumzur, and Jangbi villages) – implement project and end user

Source: DoT 2006

To facilitate successful multi-stakeholder processes, a collaboration matrix can be used. More information about this tool can be found in the Toolkit (Volume 2, Tool 4)

Factors obstructing collaboration

Despite good intentions, not all partnerships are effective and too often collaboration does not bring the expected results. Many of the co-operative initiatives are short-term initiatives rather than longer-term strategies for competitive success. Many focus only on improving comparative advantages instead of contributing to create real competitive advantages. There are several factors explaining the failure of collaboration.

The complexity of engaging diverse stakeholders in any form of decision making and collaboration makes it difficult to involve them all equally. In general, problems arise when there is no optimal (internal) functioning as there is no or inadequate consideration of the different parts of the process. If there are no clear internal procedures or responsibilities, there may be fragmentation in decision making and reduced control over implementation. Institutional factors and the strategic choices of public and private actors are often the root cause of the inability to develop good working partnerships.

Perceptions of the stakeholders also play a role. Until recently, the travel and tourism industry has been hesitant to establish public or private partnerships, because of the very competitive market within which it operates. Stakeholders may not be willing to work together with previous opponents (or with unfamiliar partners); some may be uninterested or inactive in working with others.

Caalders, and Bramwell and Lane (2000, in De Lacy et al. 2002) have identified the following factors contributing to failure of collaboration:

- Framework unclear
- Power relations dominate
- Lack of motivation, resources, and trust
- Failure to stimulate creativity and activate knowledge
- Too many different actors involved or only a limited number of stakeholders

Also, the costs of cooperation can be seen as a factor responsible for failure of collaboration. Involving a range of stakeholders (in for example policy making) may be costly and time consuming. If there is no funding for these costs, this can hamper the functioning or even the existence of a multi-stakeholder process.

Multi-stakeholder process model

Within the reality of the globalised economy, there is much discussion on how market opportunities can be opened up for the poor. Current development debates revolve around ideas on pro-poor growth, public-private partnerships, and, for instance, issues such as good governance, market access, and civil society participation. At the same time, many believe there is a connection between greater participation in democratic processes and sustainability. Traditionally, participatory approaches have focused primarily on the communication process between stakeholders and less on the institutional dimensions. An institution, however, is not identical to an organisation. In the broad sociological sense an institution can be described as any established law, custom, social practice, or organisation that forms part of the social structure and influences the regular patterns of human behaviour.

Thus, the most obvious institutional need for stakeholder collaboration is the creation of some form of platform that enables different actors to come together and that gives legitimacy to a process of interactive learning. Multi-stakeholder processes and social learning are about setting up and facilitating long-term processes that bring different groups into constructive engagement, dialogue, and decision making.

Woodhill (2005) describes a core process model, outlining the most important elements of most MSPs. Of course, as he also states, every multi-stakeholder process should be adapted to the specific needs and context of the particular situation. There is no simple and universal step-by-step model to be followed. Yet, through experience it is also clear that there are some basic elements of most multi-stakeholder processes that need at least some consideration.

The model, based on a common-sense action learning cycle, gives the following four phases (overlapping in an ongoing process cycle, see Box 7.3): setting up; planning strategically; implementation and management; and process reflection and adaption.

Like all models, this model is an oversimplification of reality. Yet, the model can be seen as an instrument for investigating the workings of multi-stakeholder mechanisms. By providing issues to consider when designing and facilitating a multi-stakeholder process, the model can be used to assess how the collaboration functions and where it might go wrong.

Lessons Learned in Tourism Multi-Stakeholder Collaborations

General findings

This section provides the main findings of several SWOT (strengths, weaknesses, opportunities, and threats) analyses (see Tool 15 in Volume 2 for a detailed explanation of the SWOT analysis) of collaboration bodies in Lao PDR, Nepal, and Vietnam at different levels (village level, district or

Box 7.3: The Four Phases of the Core Process Model

Phase		
1.	Setting Up	Exploration of reasons, focus, and direction of the initiative (establishing the reasons, mobilising community interest, and deciding what organisational and institutional arrangements are needed)
2.	Planning Strategically	Motivations and visions for the future, how to get there (undertaking detailed planning and strategy development needed for an MSP to be successful)
3.	Implementation and Managing	Managing structures and action plans (providing ongoing resources for the initiative and ensuring continued community input and support)
4.	Process Reflection and Adaptation	Monitoring and evaluation (monitoring the impact, successes, and failures, learning from these, and continually improving what is being done)

provincial level, and national level). In all three countries, multi-stakeholder collaboration is important, given the complexity of the sustainable tourism industry. The involvement of different stakeholders is needed, as all countries realise they cannot develop sustainable mountain tourism on their own. By collaborating, participants expect benefits and visible results for time, energy, resources, and skills invested. They use collaboration to fulfil their own objectives. When members realise they are benefiting, they are willing to invest.

While the objectives and participants of the different collaboration mechanisms vary, they have all helped to create awareness of pro-poor sustainable mountain tourism and have brought different stakeholders together. In relation to the reduction of poverty, besides raising awareness about sustainable mountain tourism issues, collaboration contributes indirectly through positive changes that benefit the poor like access to health, education, and markets. Some economic benefits for the poor exist through activities executed by collaborating bodies. Local-level collaborations, such as tourism management boards in villages, are responsible for the equal distribution of tourism-related income. Provincial steering committees try to stimulate tourism activities in different areas within a region to spread benefits. Many collaborating bodies, however, do not have clear internal organisation (roles and responsibilities), sometimes resulting in weak functioning and below optimal results.

Box 7.4 presents a generalisation of the main strengths and weaknesses of multi-stakeholder bodies in Lao PDR, Nepal, and Vietnam.

The involvement of a wide diversity of stakeholders from different levels and sectors assures input and expertise from different angles. For pro-poor, sustainable mountain tourism, the involvement of the private sector, in particular, helps to make collaboration useful. Visible results, committed members, and access to resources are all factors leading to successful collaboration.

Collaboration is weak when the purpose of collaboration is unclear, when roles and responsibilities are vague, and when there are no rules or operational procedures. Malfunctioning of collaboration occurs when internal monitoring and evaluation is weak and follow-up by a supporting organisation limited. Lack of experience in tourism (and management) makes it difficult to focus the collaboration on relevant objectives. A lack of visible activities influences the motivation of participants. Limited language skills (either local or English) can make communication difficult between different stakeholders.

Box 7.4: SWOT Findings of Multi-Stakeholder Bodies in Lao PDR, Nepal, and Vietnam

Strengths	Weaknesses
<ul style="list-style-type: none"> ● Involvement of diverse stakeholders ● Organisational structure: clear, transparent ● Achievements: profile raised, implementation of activities, reputation ● Members/participants: expertise in tourism; commitment, active participation ● Access: to resources and to influential persons ● Contact with private sector/ involvement ● Partnerships: creation of linkages, new relations ● Linkages levels: working at or involving different levels (micro, meso, macro) 	<ul style="list-style-type: none"> ● Internal organisation: lack of organisational structure, operational procedures ● Lack of ownership ● Involvement of private sector weak: not involved in product development ● (Internal) monitoring and evaluation: limited ● Follow-up: by support organisations lacking or not regular ● Lack of visible results ● Experience in (pro-poor sustainable) tourism low: especially in implementation and management ● Linkage levels: between national and lower levels still weak ● Language: communication difficult between national and international participants/stakeholders (no English)

The examples given in the study from Lao PDR, Nepal, and Vietnam show that multi-stakeholder collaboration exists at different levels (micro, meso, and macro level). The purpose of collaboration varies at these different levels. At the local and district level, tourism management boards and village cooperatives exist. People work together to implement and manage specific tourism activities. At the national level, collaboration is more strategic. Organisations meet to learn from each other; to put strategies together; and to explore possibilities to work together.

Within collaborating bodies, a variety of stakeholders are involved ranging from government departments, educational institutions, local communities, INGOs, NGOs, and private sector representatives. The latter, however, were under-represented in the bodies studied, especially at micro and meso levels.

The main findings of the study in Lao PDR, Vietnam, and Nepal make it clear that the organisational structure of a collaborating process is very important. This holds for all three (micro, meso, macro) levels in all three countries. Having a clear purpose and transparent decision making contributes to the effective functioning of collaboration.

Micro level

At the village level, understanding of (community-based) tourism principles and management are important for the functioning of tourism management boards and cooperatives. Other important factors at the micro level are the relations between the community and the business sector. The results of the collaboration process must be visible to maintain the motivation of the members. Following-up and monitoring activities of the collaborating process are important as well.

Meso level

Currently, provincial or district-level tourism authorities sometimes lack the capacity to fulfil their responsibility of managing sustainable mountain tourism products in districts and villages. Staff

do not always know and understand the objectives of the collaboration and are not very committed. Within provincial steering committees the motivation of members is low, resulting in lack of regularity of meetings and poor continuity on the part of people attending meetings.

Macro level

The case of the Sustainable Tourism Network (STN) in Nepal shows the potential of sustainable tourism networks in general. The advancement of STN to a more professional, organised level (own secretariat, selection criteria, membership fees) with a minimal budget is due to outside INGO support. Now, the network works towards self-sustainability and financial benefits. The rapid growth of active and committed members (even with a newly-introduced annual contribution fee) shows that the network is needed and appreciated. STN receives much international attention and is regarded as an example for other countries for collaboration at the national level.

The example of STN in Nepal shows that a multi-stakeholder process requires a flexible system to adapt to new situations, like the needs and skills of its participants, and outside factors that determine the environment in which it functions. Coordination and proactive members are crucial factors for a successful network at the national level. Actions and small successes are more important than a fully-structured and organised scheme.

Recommendations from the multi-stakeholder collaboration studies

As sustainable mountain tourism and stakeholder collaboration is relatively new in South Asia, support for multi-stakeholder collaboration at the local, provincial, and national level is necessary. To make collaboration work and to get more pro-poor growth results, activities should be focused on the pro-poor aspects of collaboration, as well as on the creation of a win-win situation for different stakeholders.

The following should receive focus to ensure successful collaboration.

- **Enhancing expertise on collaboration:** Understanding of and expertise on how to collaborate and manage a committee should be improved. Stakeholders should have an understanding and appreciation of the purpose and benefits of collaboration. A coordinator or one or two members should have some basic knowledge of how to run a network (how to prepare agendas and write minutes; how to organise meetings, familiarisation trips, and workshops; how to communicate with members; how to update a website; how to develop a newsletter). Stakeholders should also have a notion of general tourism development (tourism planning and how to develop a destination).
- **Strengthening the internal organisation and functioning:** Support is needed to professionalise committees and management boards. Especially at the lower (provincial, district, or village) levels, board members or coordinators should be strengthened in their capacity to 'run' a network (basic day-to-day activities). A multi-stakeholder process needs a clear mission and vision to work effectively according to a work plan based on these. Operational guidelines need to be in place, with agreements and engagements about, for example, the regularity of meetings (fixed days, sending agendas before meetings and providing minutes afterwards) and annual reporting.
- **Increasing the involvement of the private sector:** To have more pro-poor impact, the increased involvement of the private sector in sustainable mountain tourism and expansion of private-sector presence in collaborating bodies are needed at all levels. The awareness of the private sector of new sustainable mountain tourism products needs to be increased. The involvement of the private sector is needed to develop commercially feasible, sustainable mountain tourism products and to ensure promotion and marketing.
- **Providing support and follow-up:** Regular support and follow-up of multi-stakeholder processes are necessary, especially in the initial phase of collaboration, and should continue throughout the process.

- **Diversify financial resources:** For any multi-stakeholder process it is important to diversify financial resources, so that they are not completely dependent on an external organisation like a national tourism organisation. At the provincial and national levels, membership fees can help generate funds.
- **Political support:** Political support of national ministries, as well as the support of local, district, and provincial authorities, is essential to make collaboration work. Collaboration needs support or should be led by a government authority to give it credibility. When tourism is already a government priority (through a tourism strategy at the national, provincial, or district level) it makes implementation of activities easier.

Based on the findings of the multi-stakeholder collaboration studies specific recommendations can be made for each level:

- **Micro level:** Collaboration needs to be followed through by local capacity builders, with advisory support from INGOs.
- **Meso level:** Support should be provided to local capacity builders and more linkages should be created with the private sector (less focus on provincial tourism department or offices).
- **Macro level:** Support for initiatives like sustainable tourism networks or public-private partnerships should be continued with clear targets for support.

To ensure full participation by all, attention should also be given to the following: gender and social inclusion; the creation of linkages with other sectors (like education); and language of training (e.g., training participants in the local language or English).

Roles of NTOs and STOs

NTOs and STOs can support multi-stakeholder approaches in sustainable mountain tourism using the following approaches:

- Enhancing expertise on collaboration;
- Providing access to information and documentation on the sustainable development of tourism;
- Spreading key publications on the sustainable development of tourism and poverty alleviation to different stakeholders like provincial or district tourism organisations (providing examples of tourism development and management and of specific pro-poor issues like empowerment of groups and partnerships, which are adapted to local situations);
- Increasing the involvement of the private sector;
- Lobbying to make the private sector aware of their roles and responsibilities regarding poverty alleviation and tourism;
- Lobbying with local organisations (governments, non-government organisations, private sector) to raise awareness on the importance of collaboration within the tourism sector, between public and private sectors;
- Promoting integration between public and private sectors. Public-private partnerships can be stimulated, as well as online marketing of sustainable mountain tourism products;
- Providing support and follow-up;
- Making documentation available to local organisations on how to develop indicators and systems to measure impacts of tourism on poverty;
- Giving political support;
- Lobbying with local governments on the importance of tourism in relation to poverty alleviation;
- Formulating sustainable mountain tourism policies and legislation for poverty reduction; and
- Providing frameworks for development strategies for tourism at national and provincial levels.

Tailor-made solutions

More attention should be paid to solutions that are tailor-made for the operating context of each collaborating process. Contextual factors should be taken into account when setting up, supporting, or facilitating collaboration. The setting up of collaboration should follow an organisational structure that matches its objectives, participants, and context, instead of using a model with pre-fixed organisational criteria.

Stakeholder analysis can be useful to identify the right representatives to take part in a management board, especially at the micro level. In villages and districts, existing social structures can be used to make sure all social groups are represented (women, the elderly, and youth). Village mobilisers can be brought into action to ensure people understand the ideas behind collaboration and are indeed taking part in the board. Providing incentives can help too. Selection criteria for members of village management boards should include experience in tourism and the ability to communicate.

Gender and Social Inclusion

This chapter covers

- The conceptual framework of gender and social inclusion
- The implications of gender and social inclusion in mountain tourism, and the challenges that women face in the mountain tourism industry
- The process of mainstreaming gender and social inclusion in sustainable mountain tourism project cycles
- Skills in monitoring and evaluating the impacts of gender and social inclusion on mountain tourism development projects or programmes

Introduction: Challenges for Women in Mountain Tourism

Tourism has opened doors for many mountain societies as a means of earning a livelihood, especially for women and rural communities. Defining the tourism industry from a gender perspective is crucial, as tourism is a major employer of both women and men, with many impacts on women's lives in destination communities. Nevertheless, research on the gender dimensions of mountain tourism is still scarce. With its flexibility and capacity to include the most unskilled and disadvantaged people, such as mountain communities, women, and indigenous people, tourism has a great potential to reduce poverty among poor and socially excluded groups. It creates opportunities ranging from large-scale businesses to small cottage industries, micro-enterprises, and services. Tourism is one industry in which women's contributions are as much as men's. As stated by the International Labour Organisation (ILO), women's employment is 46 per cent of the global tourism workforce; and, in countries where tourism is a fully-fledged industry, like Nepal, the percentage could be as high as 50 per cent.

Women's role as the caretakers of households and communities at large has developed them as the prime tourism actors in destination communities. In most mountain communities, women are found engaged in cooking, managing local hotels and lodges, operating tea shops, making indigenous handicrafts, environmental conservation, cultural preservation, fruit and vegetable production, and beekeeping. Although women have a high rate of contribution and involvement in tourism, they still remain behind in terms of access to resources and benefits. Like any other sector, the tourism sector is mainly dominated by men in terms of decision making and controlling resources. The top positions in the tourism industry are mainly occupied by men in travel agencies, mountaineering, trekking, rafting companies, airlines, accommodation, and communication services, with good remuneration and involving frequent travel outside the village. Women are often found in the lower (paid) positions. Women are often a neglected stakeholder in tourism development, if seen as stakeholders at all. Different gender obstacles to women's participation in tourism have been noted (see Box 8.1). In addition, tourism often has different impacts on the lives of men and women. For example, women often feel the loss of natural resources first, but at the same time may be the first to benefit from

Box 8.1: Gender-Based Obstacles in Tourism Development in Nepal

	Individual	Household	Wider Community/National Context
Financial	Women lack access to business development services and financial services in their own right.	Men's control over cash income and men's expenditure patterns	Perceptions of men as controllers of money and loans.
Economic	Women undertake activities that produce low returns. Women have a heavy domestic workload.	Gender division of labour Unequal access and control of land, labour, and inputs Unequal control of joint household produce and income streams from this	Women are paid less for equal work. Women are locked in reproductive work or low-paid jobs. Stereotypes of appropriate roles for women in the economy Women lack access to markets for inputs and outputs if mobility is constrained due to social norms.
Sociocultural	Women not literate or educated; girls education is not prioritised.	Limited role for women in household decision making Violence towards women	Providers of business development services and financial services do not view women as a potential market. Women's mobility is constrained by social norms. Negative attitude towards business women
Political/ Legal	Women lack confidence to claim political/legal rights.	Women lack legal rights to jointly owned household assets.	Women's legal rights to household assets are not defined in law or useful for collateral. Women lack political positions to establish appropriate laws. Women lack legal support.

Source: Shrestha and Walinga 2003

infrastructural improvements that often accompany tourism development such as piped water and electricity.

There are many opportunities for women and socially-excluded groups to be empowered through tourism. The tourism industry can provide them with new entry points for (formal and informal) employment and opportunities for self-employment in small and medium-sized enterprises. Furthermore, it can allow them to carry out new roles for themselves and their families at home, as well as in the local power structures (CBOs, local governments, NGOs, and others), and to become increasingly involved in the decision-making process.

At present, however, the industry is not gender equal. To achieve balanced socioeconomic development in the sustainable mountain tourism sector, men and women, as well as different social groups with people with different skills, need to be involved. Gender-balanced and socially-inclusive tourism development is essential for sustainable mountain tourism development.

This chapter introduces the concepts of gender and social inclusion and shows how these can be mainstreamed. In the second volume, instruments that can be used to mainstream gender and social inclusion, such as a gender checklist (Tool 27), contextual analysis (Tool 5), social audit (Tool 31), and gender audit (Tool 26) are explained step by step.

Concepts of Gender Mainstreaming and Social Inclusion in Tourism

The importance of gender mainstreaming and social inclusion in tourism is paramount. The conceptual framework of gender and social inclusion needs to be understood in order to be able to mainstream both gender and social inclusion in tourism development.

Gender

Gender can be defined as the social construction of masculinity and femininity and the power relationship between men and women in society. It goes beyond the biological differences between males and females and deals with the social conception of tasks, functions, and roles attributed to women and men in the private and public spheres and to the attitudinal and behavioural treatment of males and females at all levels of society (household or family, institutions, and society at large).

Social exclusion

Social exclusion is the practical experience of different social groups who are systematically disadvantaged because they are discriminated against on the basis of their caste, gender, ethnicity, race, religion, sexual orientation, age, disability, health or HIV status, marital status (single women), migrant status, or because of remoteness or where they live. Exclusion happens in public (formal) institutions like the legal system, government offices, education, and the health system, as well as social (informal) institutions like the household (DFID 2005). There are different steps to mainstream gender and social inclusion.

Step 1: Awareness and initial participation

To increase and improve the participation of women and socially-excluded groups in tourism, affirmative action (like a quota system for capacity-building programmes), provides space for participation and prepares the ground for a favourable environment for women and socially-excluded groups to participate. While the mere presence of women and socially-excluded groups does not necessarily amount to full participation, it is a step towards mainstreaming.

Step 2: Empowered participation

Giving space to excluded groups to physically participate in a tourism programme does not necessarily mean that these groups will benefit from the programme. Participation in a tourism programme does, however, provide them with opportunities to learn and gain knowledge. This process will enhance the capacity of individuals and groups to think and analyse logically. Once they are able to consciously participate in programmes, these groups can be considered to be empowered. An empowerment programme is necessary to improve and enhance their capacities. Social mobilisation, participating in meetings, discussions, receiving encouragement, and involvement in capacity enhancement programmes, such as training, exposure visits, or familiarisation trips, helps to enhance the capacity of women and socially-excluded people to participate in an empowered way in sustainable mountain tourism development.

Step 3: Influencing and decision making

The next step in gender mainstreaming in sustainable mountain tourism is to provide space for leadership positions and build capacity for advocacy and influence in tourism organisations. This can be realised by providing space (through quotas) in decision-making positions for women and

socially-disadvantaged or marginalised groups, and by enhancing their capacity to manage resources, finances, assets, and the tourism programme itself effectively.

Step 4: Equitable sharing of benefits

The fourth step is to prepare policies, rules and regulations, and guidelines on the equitable sharing of the benefits of tourism revenue so that women and excluded groups can gain access to and control over resources. It is also necessary for women and excluded groups to enhance their capacity to increase their claim on these tourism benefits. Supportive policies, rules and regulations, and guidelines are not sufficient to distribute and receive tourism benefits. Both space for equitable sharing of benefits and an empowerment process are needed to achieve mainstreaming.

Box 8.2 presents the experiences of TRPAP, Nepal, in increasing women's participation in tourism.

Box 8.2: Case of TRPAP in Nepal

TRPAP is a tourism programme specifically designed to be pro-women, pro-poor, and pro-marginalised communities through community participation, developing backward and forward linkages, enhancing capacities, and providing access to capital for women and the poor. The programme has achieved substantial success in empowering women through entrepreneurship. It has improved their status through tourism development by providing women with entry points for employment, with opportunities to create self-employment in small and medium-sized enterprises, and by providing them with opportunities to participate in the sector in a more meaningful way. In all its activities, the programme emphasises the involvement of women and men equally in active participation and decision making.

Social mobilisation: To increase women's participation in tourism promotion, TRPAP hired women as social mobilisers (33%) to make sure that rural women's issues are not overlooked and that they don't succumb to the community demands, which are primarily dominated by men. Having women as social mobilisers has helped to make women in the villages more comfortable to come out of their homes, share problems, and to participate in activities and decision making. The TRPAP social mobilisers provided formal training and conducted awareness programmes on gender equality.

Equal participation: A quota system was set requiring a minimum of 40 per cent representation of either sex (male or female) in the formation of any community organisation. However, bringing women into the decision-making level was yet another challenge. TRPAP made a rule that the chairperson or manager of the community organisation should be a woman, thus giving women an influential position.

Representation of women in an institutional set-up: Similarly, guidelines were developed for the formation of the village-level tourism committees requiring the proper representation of women in the institutional set-up. Sustainable tourism development committees were formed with 25 per cent of seats reserved for women. These committees were recognised by the local government as grass roots' tourism institutions working for sustainable tourism development. Due to the lack of women representatives in the local authorities, the number of women found in STDCs was also negligible. However, the quota of 25 per cent made the participation of women possible to an extent, despite their non-representation in the local authorities. Today, out of the 14,650 members of TRPAP's community organisations, 7,545 are women, which is a significant 51.5 per cent.

Institutional development: Training courses have been run for sustainable tourism development section chiefs at the district level and sustainable tourism development units at the central level on gender management and development for sustainable tourism. The sustainable tourism development unit in the Nepal Tourism Board has also incorporated a gender component into their trainings as an important part of sustainable tourism development and created a separate gender portfolio in the unit, replicating the TRPAP model. As a result of TRPAP's initiatives, even in the formation of sustainable tourism development units at the central level, the ratio of women to men has been maintained at 1:2, appreciating the importance of women's involvement in sustainable development.

Box 8.2 (cont...)

Capacity enhancement: TRPAP has placed special emphasis on educating and improving women's awareness in its human resource development sector by providing women with training and non-formal education in relevant sectors and sensitising them to their potential and own progress through tourism development. Training has included English language training, business development services (including entrepreneurship development and management capacity enhancement), and skill development training with a special focus on promoting women-related indigenous skills and handicrafts for income generation. Since the inception of TRPAP, 53,880 people have been trained in capacity enhancement, the APPA approach, tourism environment and awareness programmes, and skill development programmes, with 23,699 being women beneficiaries, which is 44 per cent of the total number of people trained.

Venture capital fund: TRPAP has given first preference to requests made by women to obtain venture capital fund for tourism-related micro enterprises, and has given out loans to all women whose conditions have met the prerequisites needed for venture capital fund. The biggest problem facing women in obtaining capital has been their lack of ability in submitting proposals. Due to lack of education and confidence, they hesitate to apply for venture capital funds. TRPAP's social mobilisers especially facilitated women in proposal writing and submissions for loans. As a result, many women came up with micro enterprises such as homestays, tea shops, local lodges, handicraft sales, and so forth. Rasuwa's homestay programme is a successful model of a micro enterprise by women. Under this programme 24 homestays have been developed, all managed by women.

Infrastructure: TRPAP supports tourism infrastructures that facilitate women in their daily lives and gives such infrastructures as much importance as other community demands. Monitoring records have established that incinerators, toilets, biogas, improved cooking stoves, and drinking water sites, all of which have direct implications for the daily life of women, have been built in programme areas. For rural woman, these facilities, which were otherwise hard to come by, have been provided as part of TRPAP's pro-women initiatives in tourism development activities.

Policy-level interventions: The TRPAP programme prepared different policy documents, such as a pro-poor tourism policy draft, a National Strategic Tourism Plan, and five-year district tourism plans, all addressing gender issues in the tourism industry in a strategic manner.

Health, environment, and sanitation: Due to a lack of water and proper awareness, environmental concerns in rural areas remain at a low level, negatively affecting women's health in these areas. TRPAP addressed these concerns from a gender perspective and initiated environmentally-friendly practices. It supported the building of toilets, biogas plants, and improved cooking stoves provided with smoke hot water and solar water heaters, contributing directly to the improved health of women and their families. Women have also started using solar dryers to dry vegetables, which they sell to earn extra income, making them less economically dependent on their husbands.

Women's entrepreneurship in tourism: In TRPAP programme areas, tourism has demonstrated its potential to create jobs and encourage income-generating activities to benefit local communities. TRPAP's initiatives have provided various entry points for women's employment and opportunities to create self-employment in small and medium-sized income-generating activities, thus creating paths towards the elimination of poverty for women and local communities in developing countries. Community-based tourism initiatives, particularly by local women's groups and cooperatives, have proven to be an accessible and suitable entry point for women into the paid workforce. In some programme areas, such as Lumbini (the birthplace of Buddha), women and women's groups have started their own income-generating activities such as handicraft production. These activities have helped to create financial independence for the local Muslim women of Lumbini and challenged them to develop the necessary skills and improve their education. Financial independence and good education have led also to the improved self esteem of women and more equitable relationships in families and communities.

Mainstreaming Gender and Social Inclusion in the Tourism Project Cycle

In order to achieve true empowerment for women and other socially-excluded groups through tourism, gender and social inclusion need to be mainstreamed into every stage of the project cycle. This can be done, for instance, during the process of selection of mountain tourism sites and destinations, as part of the APPA exercises (see Chapter 6); through tourism awareness programmes; in product development; by ensuring equal access to credit and enterprise-related activities; in discussions and agreements on tourism revenue distribution mechanisms; through the development of market linkages; through training courses; and during monitoring and evaluation. Box 8.3 illustrates the gender mainstreaming results obtained using APPA by the Mountain Institute. As a guideline for ensuring gender equality in tourism projects and services in the project cycle, a gender checklist can be used (see Volume 2, Tool 27). There are two steps in mainstreaming gender and social inclusion in the different phases of the project cycle: analysis and assessment, and action or implementation.

Box 8.3: Appreciating Women's Roles in Tourism from a Regional Perspective

Three years of community-based tourism planning in Langtang and Helambu, Nepal, by The Mountain Institute has proved that the role of women in tourism and the benefits that they receive from tourism can be enhanced through an APPA approach to community planning in which the community acknowledges the value of women's contributions to tourism. Results of the project have shown that an appreciative approach that values women for their skills, and enhances their capacities in tourism as tourism and natural resource managers, achieved both conservation and the increased self-reliance of women. These results are not exclusive to Nepal. Similar results were seen in West Sikkim where women who participated in the APPA-based programme have become trekking guides and are actively involved in grass roots' NGOs that teach APPA and community-based tourism elsewhere in India. Women PRA facilitators from Nepal are using the APPA approach for community-based tourism and biodiversity conservation planning in Tibet and the Sichuan Province of China. Field practitioners from seven countries in South Asia and Africa have taken up the approach in their project areas.

Source: Lama 2000

Analysis and assessment

Baseline data are essential for addressing the proper needs and interests of the different social groups and women. Contextual analysis, social audits, gender checklists, and gender audits are useful tools for analysing and assessing the real situation of women and socially-excluded groups. The detailed steps in each tool are explained further in Volume 2. Each tool is briefly introduced below.

- **Contextual analysis:** Contextual analysis gives a picture of the society or institutions such as baseline data on demographics, conditions of the societal environment, development space, influential factors, and real needs (for more details see Volume 2, Tool 5).
- **Gender audit:** A gender audit calculates and compares the situation of women with men in society. A gender audit can be used by any organisation. It helps to define the situation of women and men and can support decision making about programme activities and priorities and, for instance, about budget allocation (for more details see Volume 2, Tool 26).
- **Gender checklist:** A gender checklist is a guideline for ensuring gender equality in tourism projects and services, and it helps in the formulation, implementation, and monitoring of gender-sensitive projects by asking questions about the gender sensitivity of organisations, projects, and documents (for more details see Volume 2, Tool 27).
- **Social audit:** A social audit gives a holistic picture of different social groups in relation to their power, access to resources, benefits, and who is deprived of benefits (for more details see Volume 2, Tool 31).

These tools will generate baseline data on the following:

- The best location to work in, local conditions, the environment, the existing social and economic situation, institutional arrangements, and political climate
- The need of the people, i.e., the people's existing social, economic, and political situation
- The priorities of women and socially-excluded groups and provisions for their involvement in decision making and equitable benefit sharing
- Budget allocation for gender mainstreaming and social inclusion programmes, and to what proportion of the population

Based on the baseline information, a tourism programme can be designed focusing on mainstreaming gender and social inclusion, as well as the empowerment of weaker groups.

Action or implementation

After a gender-balanced and socially-inclusive tourism development programme has been designed, it is essential to ensure that this programme will be properly implemented. Policies, rules and regulations, and guidelines by themselves do not ensure the qualitative measures of gender mainstreaming and social inclusion. While developing an area as a tourism destination, there are possible negative impacts that have to be considered. Usually, changes in labour relations and economic opportunities crafted by tourism development are gender blind, or can even have adverse effects on the vulnerable gender. Excessive work loads, invisibility of economic activities, the sexual objectification of women, the underpayment of women, commercial sex trade or prostitution, and an increased vulnerability to HIV and AIDS are some of the effects tourism can bring if not planned in a sustainable way (Kruk and Banskota, in preparation). Hence, the points below should be considered as a guideline for monitoring the tourism programme during implementation.

1. While implementing the programme, programme staff and management, as well as the organisational culture, should create a favourable environment for women and socially-excluded groups to participate in and discuss the programme.
2. While maintaining an enabling environment, the organisation and staff should take affirmative action to encourage women and socially-excluded people to participate by enforcing a quota system, through special consideration, and by designing programmes based on their needs.
3. Once women and socially-excluded groups are involved, the programme should focus on building their capacity by mobilising and motivating women and socially- excluded groups more effectively and providing positions for them in the decision-making process.
4. A capacity enhancement programme should be implemented for the specific target group (e.g., women and socially-excluded groups), enabling them to participate more meaningfully in the programme and to influence the organisation in more equitable sharing of its benefits (see also Box 8.4).

Box 8.4: Equitable Distribution of Tourism Benefit

The Mountain Institute has placed a lot of emphasis on the creation of equity in the distribution of tourism benefits resulting from their programmes. This equity is being created in their programmes through:

- A creation of (inclusive) associations
- A creation of committees
- The development of codes of conduct
- A standardisation of rates
- A process of participatory planning (see also Chapter 6)

Source: TMI 2007

Monitoring and Evaluation in Sustainable Mountain Tourism

Monitoring and evaluation together provide an effective tool for ensuring the quality and quantity of the programme's accomplishments in terms of mainstreaming gender and social inclusion.

Before implementation, it is necessary to distinguish among three aspects of monitoring:

1. Context
2. People who will benefit, e.g., men, women, and which social groups
3. Why the programme is being implemented (i.e., rationale)

These three aspects should be evaluated against the baseline data collected through the various gender and social inclusion tools (see 'analysis and assessment systems'). Although baseline data should ideally be available during the design phase, it could be prepared during planning or implementation of the programme. Monitoring can be done in the intervening time, whereas evaluation is done in a scheduled manner at set times, like mid-term evaluation and final evaluation. These three aspects will form the basis of the quantitative and qualitative analysis of the programme's success (DFID 2005).

More information about the process of monitoring and evaluation can be found in Chapter 11, and an example of monitoring tourism and gender equity is given in Box 8.5.

Box 8.5: Monitoring Gender Equity in Tourism

Family well-being

For many people in developing countries, both men and women, tourism can provide the first chance for formal employment. But with economic benefits, tourism employment can also bring consequences that adversely affect family well-being such as long hours and the stress that comes with the demands of shift work.

Key areas to be examined include the following:

- The consequences of tourism employment on family cohesion, women's workload, stress, and reproductive health
- The difficulties faced by women with babies and small children
- The safety of women at work with regard to dangerous activities, sexual harassment, and journeys to and from work for late shifts

Equal opportunities in formal employment

Income generation is generally the most important motive for participation by both women and men in the tourism industry, since tourism offers opportunities to disadvantaged groups, especially in remote rural areas.

Key areas to be examined include the following:

- The proportion of women in the formal and informal tourism workforce; seniority of women employees relative to their male counterparts; their relative pay and benefit packages
- Women who have managed to become entrepreneurs and owner-operators
- Training opportunities for female and male staff

Gender roles in traditional communities

Gender roles in traditional communities are often culturally determined and monitoring them is not necessarily designed to result in change. It can, however, raise awareness of the issues and help increase respect and acceptance for those men and women who break with accepted norms and take tourism entrepreneurship into their own hands.

Key areas to be examined include the following:

- The respective roles of men and women in traditional communities providing tourism services
- The proportion of women participating in tourism decision making
- Relative rewards and pay structure for men and women working in community-based tourism ventures

Context

Monitoring and evaluation provide a crucial and important tool for tracing the context. They should ask: What is the current status or situation? What has been changed by implementing the tourism programme? Has the programme had an impact on women and socially-excluded groups or their environment negatively or positively? Is the programme being implemented according to plan or not? Are any changes or adjustments needed to make the programme more effective and efficient? Are modifications necessary to address special target groups such as women and socially-excluded groups?

Monitoring and evaluation information will help to establish whether the programme is on track or has deviated; whether or not modifications are needed in the next phase; and whether or not it is an appropriate needs-based programme for the target group. Analysing this information enables needs-based design, plan, and implementation for the right target group.

People

For a tourism programme's impact on gender and social inclusion to be analysed, information is needed about social castes, economic conditions, and the sex (male or female) of programme beneficiaries. Disaggregated data should be collected on sex and the involvement and participation of social groups in the programme and their role in the decision-making process. Data are also needed about benefit sharing: Who receives benefits and how much? Who does not receive benefits? Who is excluded from the programme and from benefit sharing?

A tourism plan or programme should pay maximum attention to gender equality also. To achieve this a gender assessment can be used. This assessment examines the plan or proposal in terms of the attention paid to gender equality. It focuses on two questions: Does it give women the opportunity to participate in the project and will it benefit women?

The assessment can be carried out in different stages of the planning process. The purpose is to:

1. Estimate to what extent the project will offer women equal opportunities for participation.
2. Assess the effect that the project is most likely to have on women.
3. Formulate recommendations on how the project should be designed to empower women and avoid eventual negative effects on women.

An example of women's empowerment through good practices in tourism is given in Box 8.6.

Rationale

While implementing the programme, the rationale should be clear. It should be clear to all what is being implemented and for what reason. This rationale will form the basis for the planning, implementation, and monitoring or evaluation of the tourism programme.

Box 8.6: Good Practices

The Chhetri Sisters in Nepal – Empowering Women through Guiding

Lucky, Dicky, and Nicky Chhetri, three Nepalese sisters, are pioneers in the profession of female trekking guides. Since 1994, they have worked towards empowering women in Nepal.

In the early nineties no one would have dreamed of Nepalese women guiding a trek. Nepalese society is ruled by the orthodox Hindu religion in which women are considered second-class citizens. Their role is to be a diligent wife, a loving mother, and an obedient daughter-in-law. Society dictates that a woman should not leave her home, but the Chhetri sisters did just that.

“In 1993 we were running a restaurant and a lodge in Pokhara. We had the opportunity to meet women from all over the world. We came across some unhappy and frightened solo women travellers who had had bad experiences with their male guides. Upon hearing these stories, we felt sad and decided to do something immediately. With urging from our friends, we gathered up all our courage and entered into this uncharted territory.”

“Lucky, our oldest sister, had trained in The Himalayan Mountaineering Training Institute in Darjeeling, India, in 1990. The training sparked her interest in an adventurous life and we, her sisters, shared her feelings and dreamed of trekking in the Himalayas. This, combined with the requests from our trekking friends, gave us a unique idea for women to be trekking guides. In 1994, we started a women’s trekking guide service.”

Years earlier, during a field visit to the far west, Lucky saw the harsh lifestyles of the women. With their husbands and brothers gone to India, women were abandoned in the dry, uncultivated landscape of western Nepal. “I dreamed of working to support them. Our female trekking agency helped me realise that dream. Remembering these hard-working women, I recognised that rural women would be ideal candidates for female trekking guides and porters. This opportunity could offer them choices in what looked like an inevitably bleak future.”

“To include these women in the trekking industry, we created a training programme to provide them with the necessary skills. The early success of these first women inspired others. After a few years, women from all over the country were attracted to our programme for training and job opportunities. Some were low caste women who society looked down upon, others were socially disadvantaged and facing challenges in life. We have encouraged and motivated other Nepalese women from all backgrounds to enter the tourism industry.”

“Our aim has been, and continues to be, to empower and develop women through tourism and to encourage sustainable tourism in remote areas where there is little hope for the future.”

“It is not easy to break down social barriers in just a few years. Women trekking guides are a new concept for Nepalese society. It has been a great challenge to bring women into this industry, as society does not approve of women working as guides. But after a long struggle we have proven ourselves. Women can also work as guides if the opportunity is provided. We have demonstrated that women are mentally, physically, and emotionally as strong as men.”

Source: 3 Sisters Adventure Trekking 2007

Tourism Enterprise Development and Market Linkages

This chapter covers

- The process of facilitating the development and promotion of tourism enterprises that will benefit mountain communities, especially the poor
- The concepts of value chain and business linkages and their uses in sustainable tourism enterprise development
- Facilitating a sustainable mountain tourism enterprise development process in a logical and structural way

Introduction: Enterprise Development in the Tourism Economy

In tourism many of the poorest countries have a comparative advantage over developed countries as they have a wealth of natural and cultural tourism assets – culture, people, art, music, landscape, wildlife, and climate. This can generate employment and income for local communities, as well as contribute to the conservation of nature and culture. Promoting tourism enterprises and developing linkages between formal tourism sector businesses and mountain communities' micro and small tourism enterprises and informal economic activities is the key to generating revenue for mountain communities and minimising economic leakages. This chapter focuses on enterprise development at the tourism cluster level and the linkages between these enterprises and tourism markets (domestic and international).

Services and facilities in the sustainable tourism economy

As a complex service industry (see Chapter 5), tourism is dependent on a wide range of general and specialised services and facilities to fulfil the needs of tourists. A tourism industry chain begins with a tourist, includes travel agencies and tour operators, and ends with suppliers of services such as accommodation, transportation, and excursions.

Tourism enterprises are businesses that offer a range of services and facilities for tourists starting at the beginning of travel, or even before the tourist commences travel, through to the end. Services and facilities are classified as either infrastructure or superstructure.

Infrastructure refers to the basic facilities and services such as transportation and roads, airline services, airports, water supplies, electricity, sewage, hospital and medical services, security services, communication facilities, telephones, and post offices. The government is mostly responsible for the development of infrastructure.

Superstructure refers to those facilities and services that are created by the private sector and communities to support the tourism industry such as different kinds of accommodation, food and beverages, catering services, excursions, transportation services, and various other specialised services that cater to the demands of tourists.

The following services and facilities are considered essential for sustainable mountain tourism:

- Travel agencies, tour operators, and outfitters
- Transportation to and from destinations (air, sea, land), and within the mountain destinations itself (yak, horse, pony)
- Accommodation (hotels, resorts, lodges, home stays, camping)
- Excursions, entertainment, and recreational activities (trekking, rafting, wildlife and bird viewing, horse riding, sports, cultural shows, nature and culture heritage sightseeing, and so on)
- Catering, food, and beverage services (teahouses, restaurants, bars, pubs, and bakeries)
- Information, interpretation, and communication (guidebooks, websites, tour guides, information boards, Internet cafes, telephones, and so forth)
- Other services (portering, shopping, souvenir and gift outlets, money exchanges, banks, security, and medical and mountain rescue services)

The development of mountain tourism enterprises and ancillary local economic activities is highly dependent upon the demand for and promotion of mountain tourism products, attractions, and the place itself, and vice versa. The development and marketing of mountain tourism products and tourism enterprises, therefore, should go together as mountain tourism is a package of tourism attractions or products and tourism enterprises.

Step-by-Step Guide to Sustainable Mountain Tourism Enterprise Development

Mountain tourism value chains

The concept of a value chain is a useful instrument in order to see where and how money is flowing in a tourism economy, and thus where the main opportunities for enterprise development lie. Mountain tourism value chains describe the full range of mountain tourism activities (and the different tourism actors involved) that are required to bring a tourism product or service from conception, through the different phases of production (involving a combination of physical transformation and inputs from various tourism producers), to delivery to the final consumers (tourists). By gaining insight into where tourist expenditure goes, niches of where poor people can earn income from tourism can be identified, providing a sound basis for commercially viable tourism enterprise development. More information about tourism value and supply chains and how they can be used as an enterprise development tool, or more general tool for strategic planning and orientation, can be found in Volume 2 (Tool 16).

Mountain tourism enterprise development through value chains

The development of tourism enterprises in mountain areas can be characterised by the following:

- **Demand-led:** The development and supply of tourism products or services are motivated by choice and demand from tourists;
- **Supply-led:** The development and supply of tourism products or services are motivated by producers who decide to offer tourism products or services seeing the potential for demand; and
- **Induced by environment:** The development and supply of tourism products or services is motivated by government regulation or social pressure to produce mountain tourism products and services.

The development and sustainability of mountain tourism enterprises should be initiated from within the tourism chain itself by strengthening the tourism value chain and can be stimulated by development interventions in the tourism environment. In order to identify opportunities for interventions that develop sustainable mountain tourism enterprises in mountain areas, a thorough analysis of the value chain is the suggested first step before designing any intervention to develop tourism enterprises in mountain areas.

A tourism product and service demand chain and environment analysis helps to identify opportunities and constraints in the tourism value chain(s). It gives direction to the design of strategies to strengthen the tourism value chain(s) focused on the mountain poor. By knowing where the money flows in a tourism economy, commercial viable opportunities can be identified where the poor can gain income from tourism. In order to assess a tourism value chain, it is important to identify tourism actors and factors, and constraints and opportunities.

1. **Identify and assess tourism sector actors and factors:** such as national and international private tour operators, travel agencies, local tour operators, transport service providers, guides and porters, accommodation providers, excursion organisers, authorities that provide permits to mountain areas, other ancillary service providers, local community people, and others. Tourism sub-sector mapping is a useful tool for assessing the tourism value chain.
2. **Identify constraints and opportunities:** assessing how tourists travel through the chain to reach the mountain tourism destination helps to identify constraints and opportunities within the value chain. For example, it is useful to identify whether or not principal actors, such as tour operators, travel agencies, and trekking agencies, have strong backward linkages with local tour operators, communities, guides, transport service providers, accommodation providers, and other excursion organisers; whether there is a linkage between accommodation providers and local farm produce, such as vegetables, fruit, eggs, and meat; and whether there are linkages with cultural groups, local transportation service providers, tourism ancillary enterprises, such as craft and souvenir shops, and so on.

Constraints can be in the area of policy or relate to the environment (favourable or unfavourable) and include things as requirements for tour and trekking permits and visa processes. Other constraints can include, for instance, a lack of basic infrastructure or security. The capacity of local people to provide services and facilities can also be a constraint.

While assessing the value chain from the perspective of mountain tourism, the following questions should be asked:

- Is there the possibility of forward and backward linkages?
- Do principal actors – tour and travel operators – have sufficient information on mountain tourism products, attractions, and destinations?
- Do tour operators have sufficient options when offering tourism products to their clients or tourists?
- Are tour and travel operators interested in mountain tourism products and destinations?
- What is the main interest of the tourists: the destination, excursions, facilities, attractions, and/or activities?
- What facilities and services can be offered to tourists to attract them to mountain tourism destinations?
- What are the existing facilities and services available in the mountain community? Are these facilities sufficient, up to the required standard, or unique? Where can they be improved?
- Where are the gaps in the supply and demand of services and facilities?

Target market analysis

It is the chicken or the egg question: should one start with a target market analysis (demand-led tourism development) or start by developing tourism products (supply-led tourism development) in order to develop tourism in destinations? Looking back on the history of tourism development in the Himalayas, the development of the tourism industry was initially mainly demand-driven. However, at the moment, sustainable mountain tourism development is increasingly supply-driven.

Aggressive marketing has become an essential factor in the promotion of tourism in today's competitive market. A detailed analysis of who the potential tourists or visitors to mountain tourism destinations are is an important first element in any strategy to develop mountain tourism enterprises.

In analysing (potential) target markets, the following elements should be considered.

Which are the target markets?

Mountain tourism implies mainly nature-based tourism, cultural tourism, ethnic and tribal tourism, or village lifestyle tourism. Sometimes the characteristics of target markets of mountain tourism might differ from those of general tourism markets. Box 9.1 identifies the tourism markets for Nepal.

Box 9.1: Identification of Tourism Markets for Nepal

Volume markets:	Bangladesh, India, Sri Lanka
Value markets:	UK, Japan, Netherlands, Germany, France, Spain
Potential markets:	China, Singapore, Malaysia, Thailand, South Korea, Russia
Domestic market:	Kathmandu and other metro residents

Source: NTB 2006

The followings are types of (potential) markets for mountain tourism:

- **High-end** international tourists who are bored with the usual package tours (e.g., tours to Pokhara, Chitwan, and usual trekking routes in Nepal) and seeking new and different destinations
- **Expatriates** living in metropolitan cities looking for holidays outside the city
- **High-end urban families** (domestic tourists) seeking a short holiday trip to villages to get away from the city life and to experience farmhouse lifestyles in a village environment
- **Low-income students and young urban population** who want to experience the rural life in a different environment during their free time
- **Students and researchers** visiting mountain areas for excursions, study, and research on sociology, anthropology, culture, ethnic groups, ecotourism, the environment, natural resources, birds and animals, and flora and fauna
- **International tourists** seeking an additional short or long-haul package
- **Free independent travellers** (FITs) for long-haul tours and trekking

Socioeconomic and demographic characteristics of the target market

As tourism enterprises are highly dependent on the target market's purchasing behaviour and interests, the target market's hobbies, demographic characteristics (such as age, sex, nationality, and sociocultural background), and economic characteristics should be thoroughly analysed.

Assess travel chain

More than half of the information on the target market can be collected through an assessment of the travel chain; information such as where the target market gets its information (e.g., from guidebooks,

websites, or travel agents), whether they come through organised tourism chains (international, national, and local tour operators) or whether they organise the trip themselves, and the mode of transportation required to reach the destination should be thoroughly assessed.

Knowing about tourists' holiday packages

The target market's holiday times, seasons, means of transportation, average length of stay, areas of interest in tourism activities, and possible desired services and products should be identified as much as possible to be able to offer suitable services, activities, and facilities. Marketing tools help to draw tourists to a location. Box 9.2 gives an example of marketing tools used by the NTB to attract tourists to Nepal.

Box 9.2: Tourism Promotion in Nepal

The Nepal Tourism Board uses a number of tools to attract tourists to Nepal and to stay informed about the market:

- Branding
- Production and distribution of information collateral
- Documentary production and broadcasting
- Participation in international travel trade fairs
- Familiarisation trips for press and members of the travel trade
- Web marketing (www.welcomenepal.com)
- Advertisement
- Informal gathering and networking of stakeholders
- Organising events and festivals
- Promotion through public relations' representatives and Nepalese embassies abroad
- Press releases through media centre
- Encourage promotion through 'word of mouth'
- Sales' missions, road shows, press conferences, tour operator meets

Source: NTB 2006

Market positioning and development of mountain tourism enterprises

Once the market (potential market) is defined, mountain tourism destinations, products, services, and facilities should be customised and developed. For the effective development, implementation, and management of mountain tourism, close collaboration and coordination between the private sector, governments, and local communities are essential. As mountain tourism is a compound product, it demands high levels of commitment, investment, and support services from different actors. The following investments are needed:

- **Government investment** in building roads, trails, and public toilets; providing telecommunications, electricity, drinking water supplies, sewage and sanitation, and tourist information centres; and in maintaining peace and security
- **Private sector and community investment** in the development of enterprises to provide facilities and services to tourists such as food, accommodation, tours, excursions, tourist product shops, tourist information centres, transportation to and from the destination, local transportation, entertainment and recreational activities, tourist information services, guide and porter services, and other services such as money exchanges, banks, medical, and rescue services
- **Institutional support** in the form of regulatory support for visas, trekking fees, trekking permits, standards and licensing requirements for hotels and travel agencies and for other services, education and training institutes, and programmes to develop human resources (guides, planners, managers, field workers), financial institutions to provide capital for investment in mountain tourism, marketing strategies, and promotional programmes to inform target markets about

mountain tourism products; organisational structures like government tourism offices, private sector tourism associations, community-based organisations, and community-based tourism associations are required to provide the above-mentioned support and – if they do not already exist – must be developed.

Figure 9.1 illustrates how these types of investment and support together form the basis for the development of a mountain tourism product or destination.

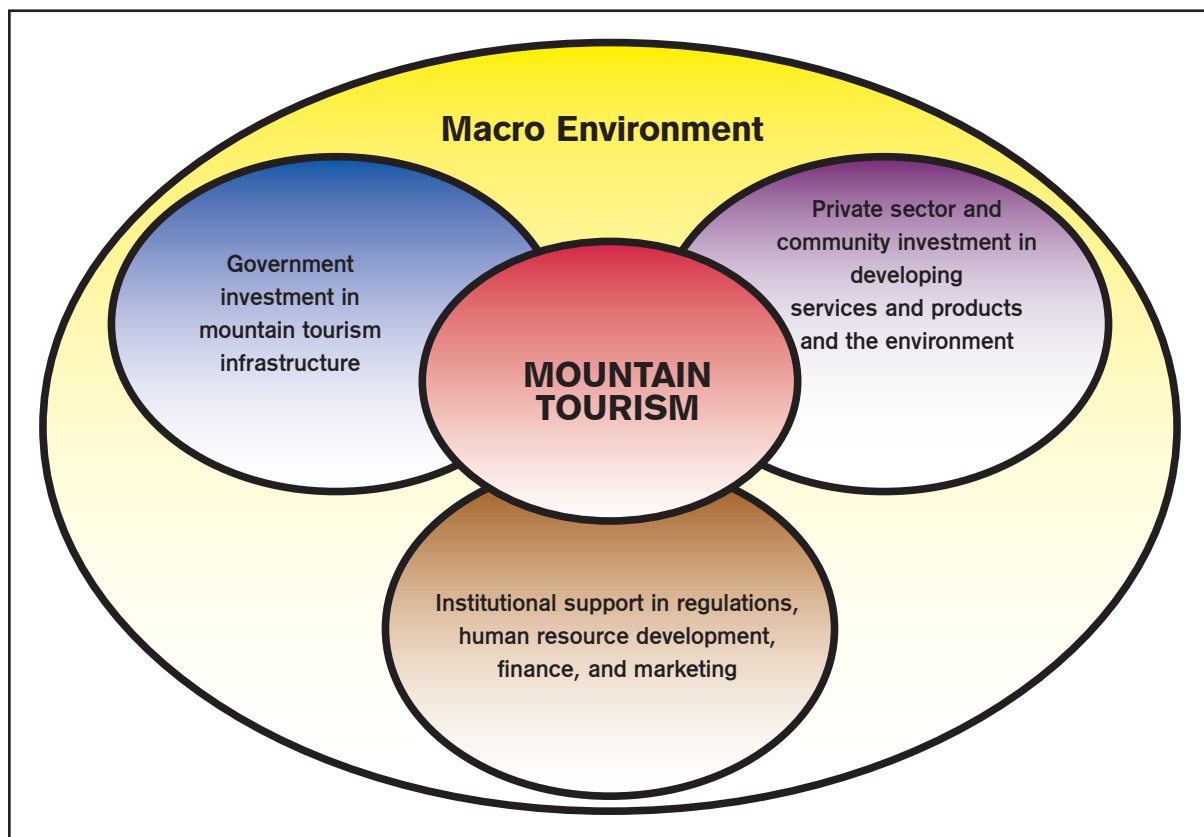

Figure 9.1: Development of a mountain tourism product or destination

When developing tourism enterprises and ancillary businesses, markets can be segmented in order to offer customised services and facilities. Before developing mountain tourism products, there must be clarity about the selling proposition of particular attractions or places or activities, which in turn helps to segment markets and develop services (marketing mix). As demand for mountain tourism products and services varies according to the type of tourist, their socioeconomic and cultural background, and nationality, services and/or products have to be developed and customised in terms of price, facilities, and quality to suit the tourist market. For example, to promote historic tourism in Lumbini, Nepal – the birthplace of Lord Buddha – tourism products and services should be developed and offered to tourists with an interest in history, archaeology, and Buddhism. Based on the main attractions, other chain products and service enterprises should be developed. The more services (choices) offered, the longer the chain of products and services, the higher the level of tourist satisfaction and, hence, the higher the number of business transactions and benefits to the host community. Possible ways of analysing the market for developing mountain tourism include the following:

- Carry out a detailed assessment or rapid assessment of the mountain tourism market
- Collect information through the organised tourism chain (e.g., trekking agencies, tour operators, and travel agencies) on incoming tourists, their interest in tourism attractions, destination management, entertainment activities, length of stay, additional facilities, and demand for services and additional activities

- Conduct periodic discussions and meetings to share information with private tour operators, trekking agencies, guides, and industry associations about the range of mountain tourism products and packages offered by these private organisations (identifying the areas where demand for mountain tourism products can be created and possible additional services added) and to orient them on pro-poor sustainable mountain tourism – not only as their corporate social responsibility, but also as a marketing tool
- Gather information about FITs, backpackers, individual domestic tourists, students, and researchers to create a full picture of tourist demand
- Establish a feedback box at tourist information centres and market centres so that the local community can obtain information on tourist demands and suggestions
- Use media to carry out tourist demand surveys in city centres; this approach is also good for obtaining information about the additional demands of tourists who come through the organised tourism chain, group tourists, and from the young urban population, students, and high-end urban families
- Collection of feedback through emails and other correspondence
- Interaction with guides and porters about the demands of tourists

Looking at the overall tourism market, there is a relatively small niche market for mountain tourism. At the same time there is high growth potential for diversifying other facilities and services: for example, if nature trekking and touring to Dolpa is the main attraction (selling proposition) for nature lovers, the provision of other products (such as cultural tourism, white water rafting, and other activities, excursions, and services) expands the scope of tourism business in the area. A survey example about visitor interests in Lumbini is provided in Box 9.3.

Figure 9.2 shows the supply chain of possible tourism products and service enterprises, particularly in the context of mountain tourism destinations.

Box 9.3: Visitor Interests in Lumbini, Nepal

A visitor survey carried out in the Lumbini area, the birthplace of Lord Buddha, in March-April 2004, shows that more than 74 per cent of visitors were interested in visiting archaeological sites related to Lord Buddha. Visits to a Lord Buddha museum, evening dance and music, and locally-made crafts generated considerable interest. Rickshaw and bicycle tours and guided walks around the Lumbini area were also identified as interesting tourism products.

Developing the scope of mountain tourism in terms of creating economic and livelihood benefits for local, poor communities is the underlying theme of pro-poor sustainable mountain tourism. Hence, building the capacity of local communities to offer a range of services, facilities, and products is essential to maximise the tourism income for the poor and minimise economic leakages at the destination.

Mountain tourism enterprises' marketing mix

The promotion of mountain tourism enterprises depends on the marketing strategy of the mountain tourism industry as a whole. When packaging and offering mountain tourism packages, a thorough analysis of the following principal components of the tourism marketing mix is essential.

Supply side

Products and place: What attractions, major activities, excursions and entertainment, accommodation, other facilities, support services and amenities, such as health and rescue services, and security, are financially more suitable for attracting tourists and for the management of tourism services?

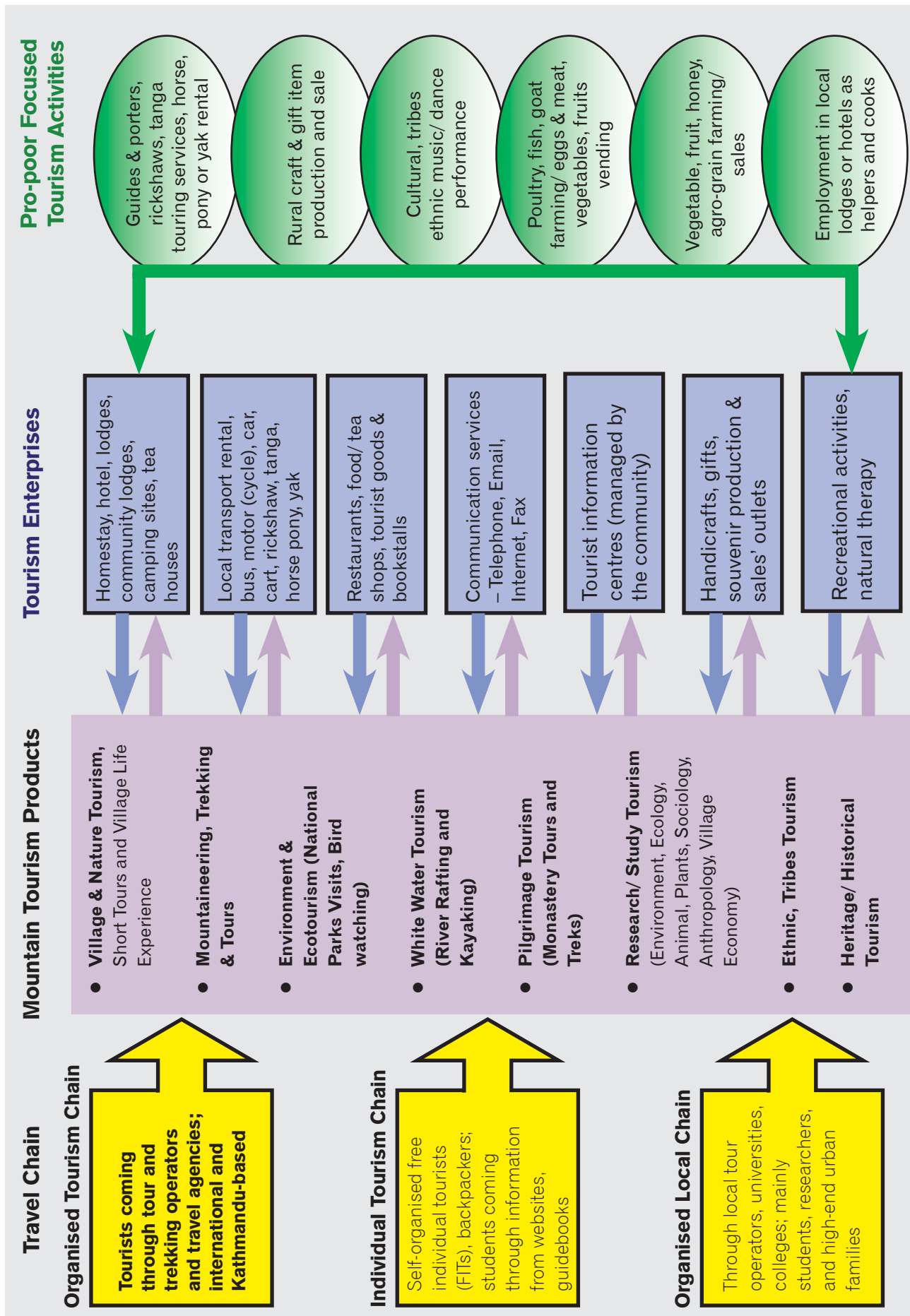

Figure 9.2: Mountain tourism products and services' chain

Place and accessibility: How do the targeted tourists travel to the destinations, i.e., by what means of transportation and service? Are there organised means of transport to mountain destinations?

Pricing: What should be the pricing strategy? Pricing depends on whether high-end or low-end, or domestic or international tourists are targeted. The pricing strategy for mountain tourism services might be influenced by partnership and collaboration with private tour operators.

Creating a moment of truth: Creating memorable events by offering more choice, quality, well-managed services, and warm hospitality is one of the winning strategies of the supply side of the tourism industry.

For the development of mountain tourism products and enterprises, partnership and collaboration with the private sector are highly recommended to ensure the commercial viability of tourism products. The following are different forms of partnerships that can be established:

- **Consortium** can be formed between the private sector and government to develop joint technology and joint services (public-private partnership, see also Chapter 12).
- **Joint venture** can be agreed between the community and private tour operators and travel agencies to bring together resources, skills, marketing information, and a 'corporate entity'.
- **Strategic alliance** can be formed with a long-term agreement between a large tourism company and smaller tourism enterprises in the community to complement services, resources, expertise, skills and for market development. An alliance can be effective in improving the destination, tourism products and services, and for marketing and promotion. For example, an alliance between domestic and international tour operators is an effective tool for international marketing.
- **Collective marketing** is joint promotion by a group of enterprises from the community to maximise the distribution and promote the networks of various partner enterprises (both horizontal and vertical networks).
- **Value chain relationship** is where different enterprises with complementary resources and skills create and promote tourism products or services. This type of relationship exists and is very strong among mountain tourism entrepreneurs, tour operators, and marketing agencies – for example, the commercial chain among tour operators, transport service providers, excursion organisers, and local homestay service providers. Such a relationship not only develops the service but also markets services as well as interdependent enterprises.
- **Organisational networks** and alliances can be used to promote mountain tourism destinations and include government networks and the networks of donors, private enterprises, communities, community enterprises, tourism representative associations, fair trade organisations, local NGOs, and so on.
- **Outsourcing or subcontracting** between large tour operators and the mountain community is another form of business partnership between the private sector and community enterprises. For example, the community can be subcontracted to manage accommodation, food, entertainment activities, and the destination in general.

Partnerships and collaboration between or among the private sector, community, and public sector are beneficial in many ways. Such partnerships give communities access to capital, investment, and risk sharing opportunities; improve services and products; increase access to skills and knowledge in tourism business planning, management, and operation; increase access to new markets; and enhance market credibility. For specific information on partnerships and multi-stakeholder collaboration in sustainable mountain tourism see Chapter 7.

Demand side

People: What types of tourists are visiting or have the potential to visit (international tourists through organised channels, FITs, domestic tourists)? What is the purpose of their visit (holiday, adventure, study, or research), their demographic and socioeconomic characteristics, their purchasing behaviour, and interests? What other services are required to satisfy their needs?

Promotion: How can the targeted tourists be informed about mountain tourism products – through websites, private tour operators, travel agencies, guidebooks, advertisements in the media and in magazines, yellow pages, or exhibitions? Various studies show that eco-environment and wildlife tourism, mountaineering and trekking tourism, nature sightseeing tourism, and cultural and historical heritage tourism are the major mountain tourism products in high demand. This is also substantiated by a visitor survey in the TRPAP area carried out by TRPAP in 2003. This study showed that for the majority of international tourists the sources of information are guidebooks, family and friends, websites, newspapers and magazines, and national and international travel agents.

Aggressive promotion can create demand for mountain tourism. An example of branding from Nepal is given in Box 9.4. At the same time well-packaged diversified products and services should also be offered.

Box 9.4: Branding Nepal – Once Is Not Enough



In 2006, the Nepal Tourism Board developed and launched their new brand “**Unleash Yourself**” **Naturally Nepal – Once Is Not Enough**. Naturally Nepal is a simple expression that repackages the brand ‘Nepal’ in a positive light. ‘Once is not enough’ not only captures the sentiment of tourists when leaving, but also serves as a decision-making tool that enables the Nepali tourism industry, individually and collectively, to focus on customer retention rather than acquisition. It also reflects the composition of tourists to Nepal where nearly 40 per cent are repeat visitors. It says that Nepal’s abundant beauty and diversity take multiple visits to enjoy: it is a multi-faceted destination that gives tourists many reasons to return.

The re-launching of brand Nepal has been done for five business reasons:

- More compelling – to repackage the diverse, existing products on offer
- More tourists – to increase the number of tourists visiting Nepal
- More money – to increase revenue to the nation
- More focus – to align the NTB’s stakeholders and the Nepali tourism industry with a common future
- More consistency – to define branding guidelines and investment vehicles to build a low-cost international consumer brand in the very competitive tourism industry

Over the next 10 years, Nepal as a brand will be promoted as “the next-generation mountain destination for weekend breaks, adventure holidays, and lifetime experiences” for people who live in cosmopolitan cities and travel internationally. The new Nepal brand is expected to be instrumental in addressing the needs of all existing and emerging tourists in Nepal’s target markets. A series of campaign activities tied to the branding process should keep Nepal competitive.

Source: NTB 2006

Various market studies show that in today's global market, Internet promotion and strategic alliances with international tour operators are an effective way of promoting tourism. Recommended approaches for marketing mountain tourism destinations include the following for instance:

- **Themed marketing campaigns** with joint initiatives by public and private sector
- **Branding of mountain tourism** products and destinations in collaboration with private travel agencies
- Bringing mountain tourism products or enterprises to large-scale tour operators through tourism **packages** (forward linkages or packaging)
- **Collaboration and partnerships** in the management and operation of community tourism enterprises
- **Sub-contracting** of community or mountain-based tourism enterprises by established tour operators and trekking agencies (see also Volume 2, Tool 20)
- The creation of **franchises** for credible accommodation and food services in mountain areas
- **Backward linkages** with ancillary enterprises such as health and meditation services, natural therapy services, and herbal beauty clinics
- **Aggressive media promotion and Internet promotion**
- **Guidebooks** on mountain tourism destinations
- Establish **web links** between sites for mountain tourism destinations and mountain tourism enterprises such as home stays, lodges, and guide services and larger tour operators' websites
- **Sensitise** private sector tour operators and tourism-related businesses to the issues and principles of responsible tourism, pro-poor sustainable mountain tourism, and fair trade in tourism (promoting corporate social responsibilities)
- **Promote partnerships between tourism e-marketing agencies and local community enterprises** (for example, the case of world hotel-link.com in Vietnam)
- **Print and e-media advertising** targeting segmented markets such as advertising in fashion magazines, TV commercials, and so on

The marketing mix of mountain tourism products in the Tourism for Rural Poverty Alleviation Programme (TRPAP) can be considered as an example (see Box 9.5).

In order to ensure the commercial viability of a mountain tourism enterprise, community tourism enterprises need to be linked to the international or domestic market. Brokers can facilitate this process of commercial linkage. They can provide access to markets, commercial skills, finance, branding, packaging, start-up payment and investment, and help with corporate identity. The different types of brokers and the roles they play in the facilitation of this process are depicted in Figure 9.3.

Apart from brokers, different business services can support the development of tourism enterprises. In Figure 9.4, some of the main supporting services are summarised. More information on business development services can be found in Volume 2 (Tool 19).

Box 9.5: Marketing Mix for Tourism Products in TRPAP

Mountain tourism: concepts and products

- Village and nature tourism (Rasuwa, Taplejung, Chitwan)
- Eco and wildlife tourism (Chitwan, Rasuwa)
- Mountaineering and trekking tourism (Solokhumbu, Kanchanjungha Taplejung, Rasuwa Langtang, Dolpa)
- Historical, archaeological heritage tourism (Lumbini, Chitwan Chepang tribes)
- Pilgrimage tourism (Rupandehi, Taplejung)
- Ethnic and cultural tourism
- Research and study tourism
- White water tourism, e.g., kayaking, rafting (Dolpa, Chitwan)
- Sports' tourism e.g., bungee jumping, mountain biking, elephant polo, paragliding (Chitwan)

Place, products/services, creating a moment of truth, activities, accessibility, accommodation, and amenities

- Package tours and excursions through agencies, operators, and guides (unorganised and organised)
- Short package tours and trekking
- Homestays and accommodation
- Mountain biking and rickshaw tours
- Trail trekking, eco-trekking, and camping
- Guided village walks and interactions with villagers
- Ethnic cultural performances
- Water excursions, e.g., rafting, kayaking, hot springs, and fishing
- Wildlife, e.g., jungle tours and bird watching
- Flora and fauna tours
- Meditation and natural therapies, health camps, and relaxation
- Village lifestyle tours, e.g., farmhouse holiday packages

People and pricing strategies

- High and medium pricing strategy for international tourists from organised chains
- Medium and low pricing strategy for domestic tourists, e.g., urban tourists, students, and researchers
- Medium and low pricing strategy for FITs

Promotion

- Business linkages with tour operators, trekking agencies and guides, hotels and cafes, e-marketing agencies, and web links with tour operators (see also Tool 19, Volume 2)
- Orientation to tour and trekking guide groups on mountain tourism products and services
- Publication and dissemination of brochures, leaflets, and audiovisual shows to private tour operators, colleges, tourist information centres, diplomatic agencies, embassies located in Nepal, associations such as TAAN, NATA, TURGAN, HAN*, craft shops in market centres, restaurants, and cafes
- Advertisements in Yellow Pages, Nepal Traveller, local and international magazines, and on TV
- Guidebooks, websites, and direct mailing to organisations and individuals

* TAAN: Trekking Agents Association of Nepal; NATA: Nepal Association of Travel Agents; TURGAN: Tourist Guide Association of Nepal; HAN: Hotel Association of Nepal

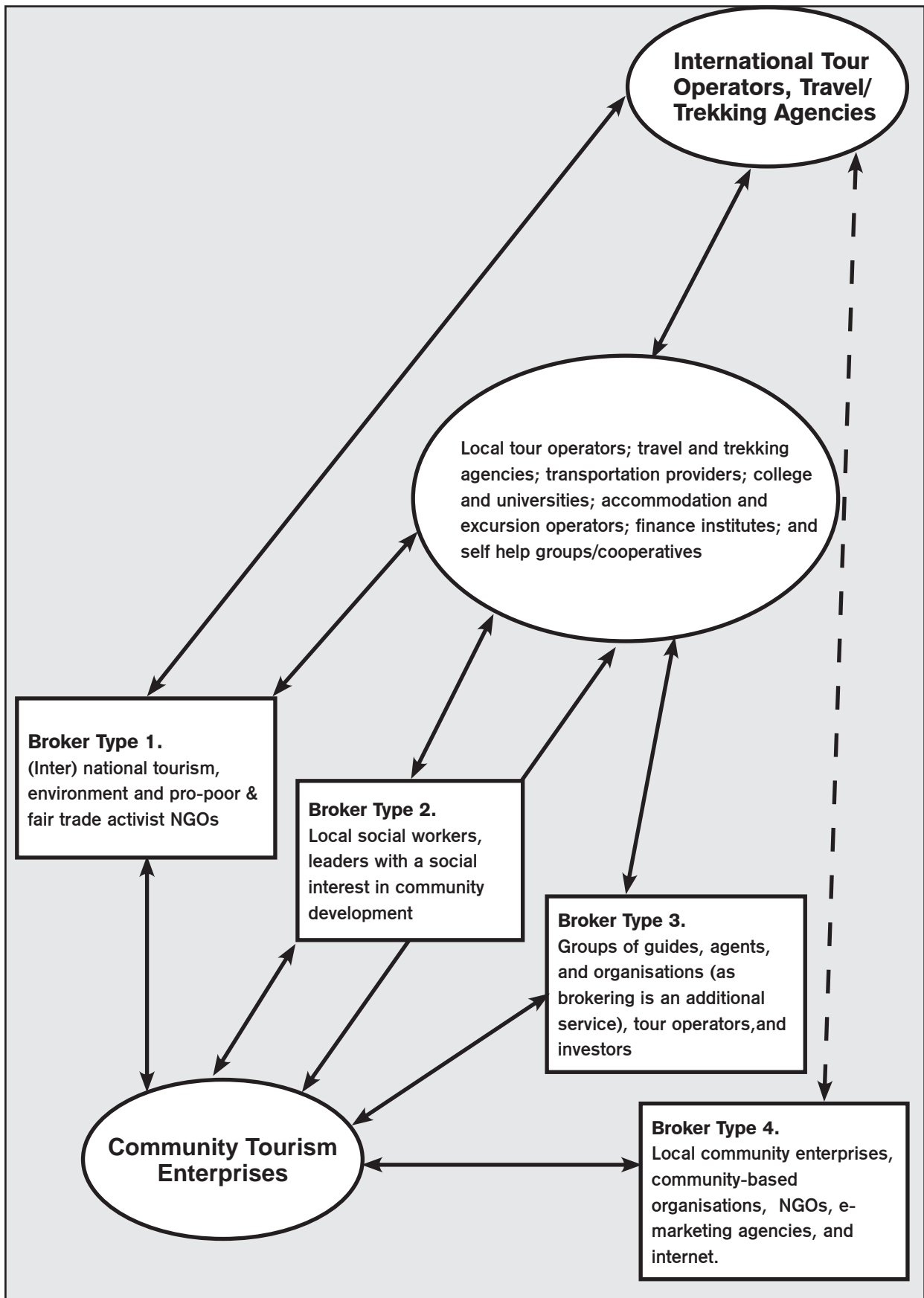

Figure 9.3: Developing commercial linkages between community tourism enterprises and private operators and service organisations

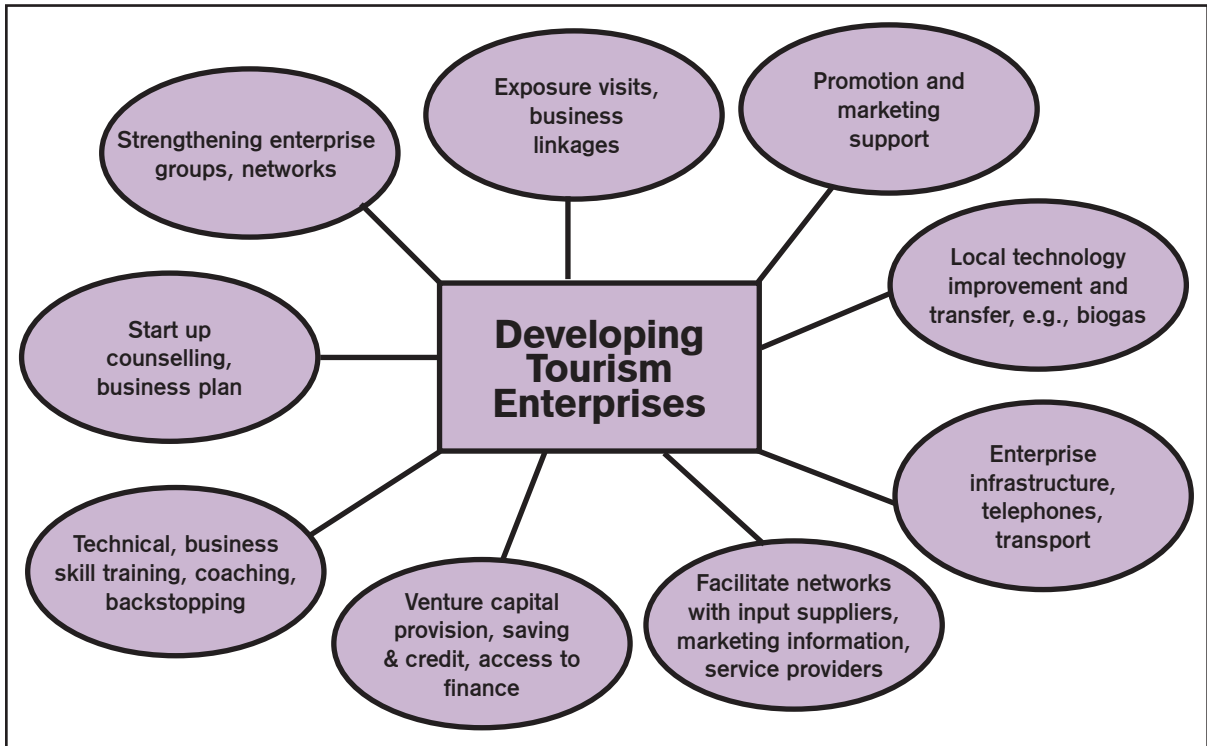

Figure 9.4: Business services that support developing tourism enterprises

GIS for Planning and Development

This chapter covers

- The concept of a geographic information system (GIS) and its application to sustainable mountain tourism planning and development
- Skilful application of GIS in mountain tourism in developing tourism resource inventories, interactive mapping and visualisation, and suitability analysis and mapping

Introduction: GIS in Tourism

Tourism deals with places and much of the information that is required for tourism planning and development is inherently spatial in nature. Geographic information systems (GIS) are emerging as a powerful tool and offer a ‘toolbox’ that helps planners and decision makers to make informed decisions. Decisions on sustainable and equitable development need to be based on accurate and reliable information. Spatial information, in particular, has a significant role in decision-making processes and is even more important in mountain areas due to the harsh topography. This chapter describes the potential use of GIS for mountain tourism with some illustrations of its applications through case studies from the region.

The spatial dimensions of mountain tourism

Mountain areas contain a vast array of natural resources with snow-capped mountains, rolling hills, winding rivers, deep gorges, and blooming valleys. They are rich in biodiversity, often contain numerous pilgrimage sites, and have diverse cultural heritages and socioeconomic practices. As indicated in Chapter 3, mountains have much potential for tourism development.

The role of geography and spatial planning holds prominence in mountain areas due to its high spatial variability – one of the most influential factors in tourism decision-making processes. GIS offers a viable and promising spatial planning platform from which to integrate and analyse the different sources of information that are required for sustainable tourism planning and management.

What is a geographic information system?

In simplest terms, GIS is a tool for planning and decision making. Tourism, as a movement of people to, and their stay in, various destinations (see Chapter 3), is related to place and time by definition and, therefore, always determined by location or a geographic component. Tourism, as well as other major challenges faced in the world today, such as migration, over-population, deforestation, and natural disasters, has a critical geographic dimension. Sustainable development needs to be based on accurate and reliable information with respect to time and space. In a GIS, the geography can be considered as a number of related data layers as illustrated in Figure 10.1.

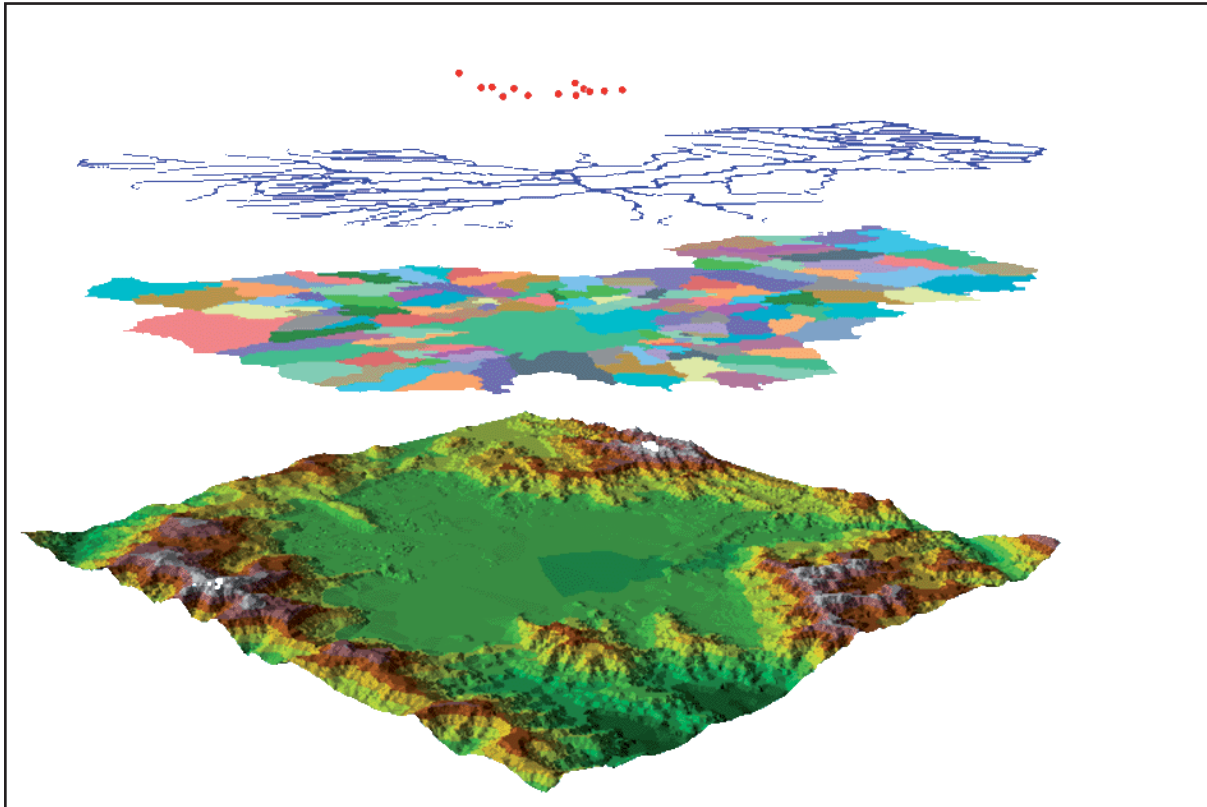

Figure 10.1: GIS as a system of multiple layers

GIS combines layers of information about a place to give an understanding of that place. Which layers of information are combined depends on the purpose: for example, finding the best location for a new tourist location, assessing environmental impact of tourism, managing natural and cultural resources, or modelling the global environment. A GIS stores information about the world as a collection of thematic layers that can be linked together by geography. This simple but extremely powerful and versatile concept has proven invaluable for solving many real-world problems, and has many applications for tourism.

GIS for Sustainable Mountain Tourism Planning and Development

Planning and decision making in sustainable tourism development is often a complex task because it involves a critical balance between social, economic, and ecological aspects that need to be analysed in a spatial context. Furthermore, compared to the plains and lowlands, the physical characteristics of mountains are complex and need to be analysed using a three-dimensional approach to arrive at an approximate representation of the topography. The application of GIS technologies to the mountain environment involves special considerations and much depends on the knowledge of the particular characteristics of the mountain environment and the understanding of how mountain systems work.

The use of GIS in sustainable tourism development and planning demands data and information from a range of disciplines and often involves multiple agencies (see Chapter 7). Information required may include information about natural resources, cultural heritage attractions, environmental sensitivities, access routes, and transportation, as well as information on the potential economic and social impacts of tourism (see Box 10.1). Effective tourism planning also requires monitoring and feedback mechanisms on the effect of planning decisions on tourism resources.

Although there has been limited application of GIS technology in mountain tourism, there is an increasing realisation of its potential for tourism planning, development, and promotion. The

Box 10.1: Making GIS Answer

GIS is an analytical tool that helps to plan and manage mountain tourism. It can be distinguished by listing the types of questions it can answer.

Location: What is at...?

This question seeks to find what exists at a particular location – such as a hotel or a restaurant. A location can be described in many ways using, for example, a place name, postcode, or geographic reference such as longitude or latitude.

Condition: Where is it?

This question is the converse of the first and requires spatial data to answer. Instead of identifying what exists at a given location, one may wish to find locations where certain conditions are satisfied (e.g., the location of a 5-star hotel within 20 minutes walking distance from the city centre).

Trends: What has changed since...?

This question might involve both of the first two and seeks to find the differences within an area over time, e.g., changes in cultural heritage due to tourism impacts or the extent of urbanisation over the last ten years.

Patterns: What spatial pattern exists?

This question is more sophisticated. It might be asked to determine whether tourism-related crimes are occurring mostly near the city centre or to find out which tourist attractions are visited most frequently. It might be just as important to know how many anomalies there are and where they are located.

Modelling: What if...?

This question is posed to determine what happens if... For example, what if the number of tourists doubles in five years time in the national park, what would be the impacts on the ecosystem? Answering this type of question requires both geographic and other information (as well as specific models).

phenomenal growth of GIS tools in the recent past, as well as revolutionary products like Google Earth that have unprecedented visualisation capabilities, have opened up the possibility of using GIS for sustainable mountain tourism development and promotion purposes. Some of the GIS applications that are used in the sustainable mountain tourism sector are briefly described in the next section.

Potential GIS Applications in Mountain Tourism

Tourism is a composite of activities, facilities, services, and industries that deliver a travel experience for both domestic and foreign travellers that includes various services such as transportation, accommodation, eating and drinking establishments, entertainment, recreation, historical and cultural experiences, destination attractions, religious pilgrimages, trekking and mountaineering, and shopping. As tourism implies travel from one place to another, location-based information has a special significance in the tourism industry. Cartography and making maps of tourism destinations are common ways of providing basic information to travellers. Such information is also increasingly made available online using interactive Internet mapping technology which gives travellers easy access to tourism-related information, helping them to plan their travels. Likewise, the use of GIS for sustainable tourism development is increasing. The following paragraphs presents some of the (potential) applications of GIS in sustainable mountain tourism planning and development. These applications illustrate the visualisation and analytical capabilities of GIS and GIS's relationship to the decision-making process.

Tourism resource inventory

GIS helps to make a systematic inventory of tourism resources in a spatial context. Such an inventory helps to create a tourism resource profile which is generally used to assess and monitor existing tourism services and facilities. This profile helps planners and other stakeholders to consolidate future plans for tourism development and enhance tourism services and facilities. It also helps travellers to find detailed information about their areas of interest. With the advent of the Internet and mapping technology, such information is also available online. The Tourism for Rural Poverty Alleviation Programme (TRPAP) in Nepal has developed such profiles using GIS in six targeted districts of Nepal. Detailed district-level biophysical and socioeconomic GIS databases have been developed using a participatory approach involving local stakeholders. Furthermore, GIS has helped to increase community participation and collaboration among different agencies. TRPAP emphasised the use of GIS for the integration of different datasets and, using its analytical capabilities, various resource maps were generated which are useful for sustainable tourism development policies and strategies. Some of the output maps are illustrated below (Figures 10.2 and 10.3).



Figure 10.2: Priority areas for tourism development in Taplejung District

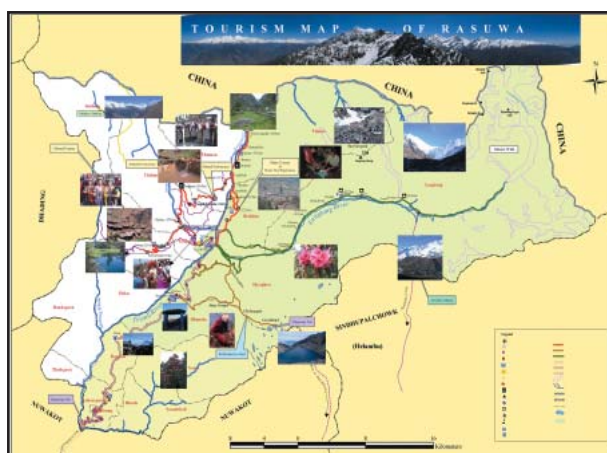

Figure 10.3: Tourism attraction map of Rasuwa

Interactive mapping and visualisation

Tourist-related information is geo-coded, i.e., information is tied to a geographic location or coordinate. A key facet of GIS is its ability to produce a three-dimensional visualisation. The marriage of GIS with Internet technologies has given rise to a plethora of interactive mapping applications on the web with realistic (3-D) visualisation capabilities. It is now quite common for tourists to choose their destination using products like Google or Yahoo maps on the Internet. Products like Google Earth have provided unprecedented opportunities to integrate tourist-related information.

ICIMOD, together with SNV-Nepal, has developed an application to integrate tourist-related information about Dolpo district, Nepal, in the Google Earth environment as an interactive mapping application. The study was a part of the Great Himalayan Trail preparatory study. This application has special importance for mountain areas due to remoteness, difficult topography, and, often, limited amounts of information. These applications are made available in the form of multimedia CD-ROMs, as well as through ICIMOD's Mountain GeoPortal website (<http://menris.icimod.net>). These tools offer an excellent way of understanding the complex mountain landscape with different perspectives. There has been very positive feedback from different stakeholders on the utility of such products for tourism promotion and development. The application has the potential to increase public participation. The maps below show some screens of the application, but one has to access interactively on a computer to appreciate the full potential of such applications (Figure 10.4)

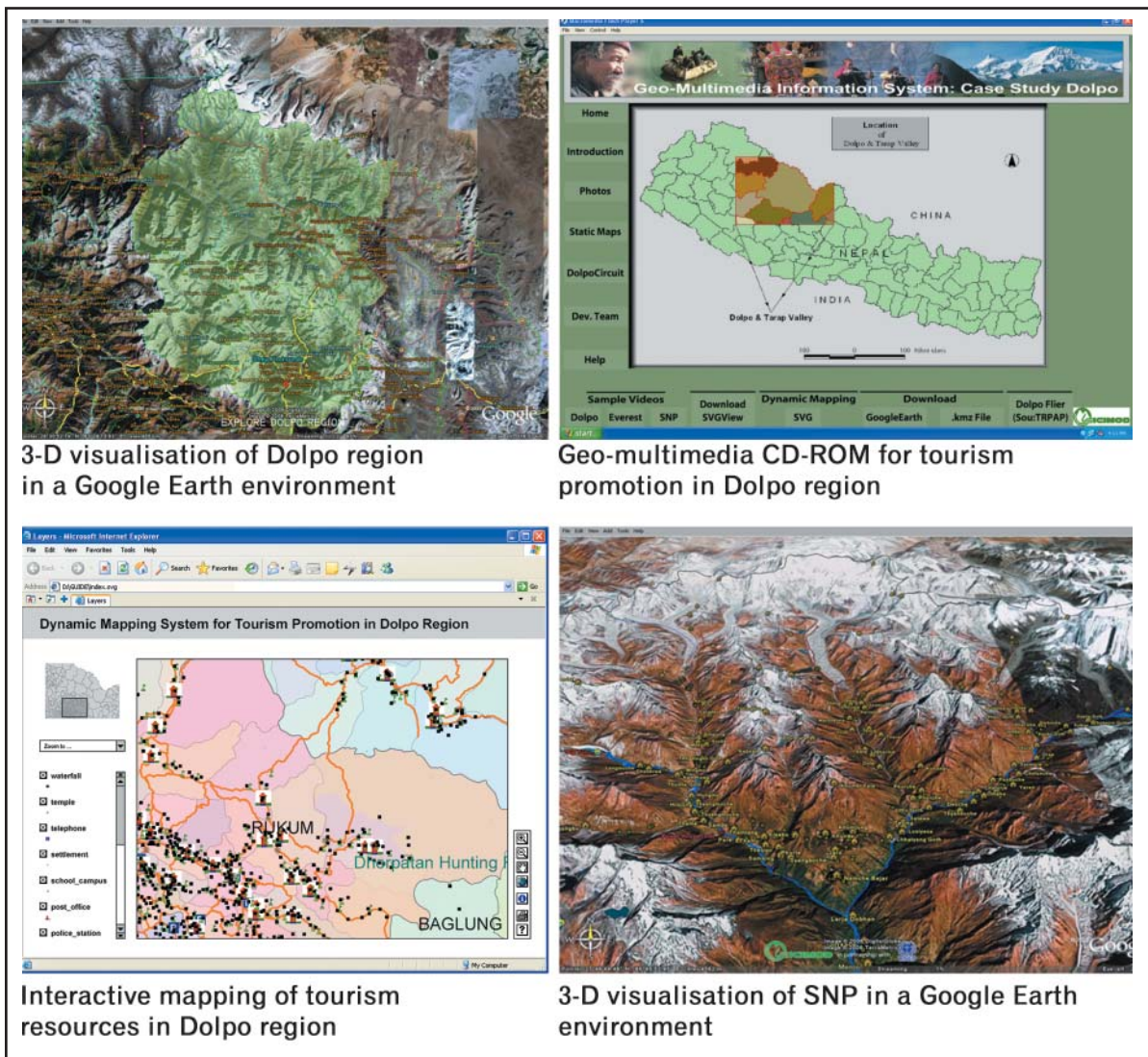

Figure 10.4: The Dolpo prototype

Suitability analysis and mapping

GIS can be used for the mapping of areas that are suitable or unsuitable for tourism development. The existence of constraints within the landscape may be used to delimit those areas that are unsuitable or less suitable for a particular development. These types of application are useful in planning tourism infrastructure, for instance, in determining land-use zonation for potential ecotourism sites to demarcate specific areas for different types of land use. GIS can be used to identify a suitable location for a resort, explore conflicts, and examine tourism impacts. The following maps illustrate indicative applications developed during ICIMOD training courses as part of a short project done by students in Myanmar and Nepal. The maps below show bird habitats and a potential site for tourism development (Figures 10.5 and 10.6)

Other examples (Figures 10.7 and 10.8) illustrate the possibility of using GIS to identify suitable locations for tourism viewpoints. Using the three-dimensional analytical capabilities of GIS, new locations are determined based on the criteria that the major peaks in the Sagarmatha (Everest) National Park should be visible from that location. Also a new trekking route has been identified in the national park using cost-distance modelling and considering different parameters such as environmental considerations, connecting different settlements, and the existence of other infrastructure.

The Future Role of GIS in Sustainable Mountain Tourism

In an information society, the role of GIS is expected to continue to grow in terms of technology, data, and application in a wide variety of disciplines. Although the use of GIS by ICIMOD in sustainable mountain tourism development is in the initial stages, the indicative applications presented in this chapter show that GIS has considerable scope for tourism applications in the future. GIS offers powerful tools for sustainable mountain tourism planning and development and can be used in such things as ecotourism development, tourism infrastructure planning, tourism carrying capacity assessment, GIS-based tourism information systems, spatial decision-support systems on tourism impact analysis, and more. With the diffusion of GIS through a large part of the society, it is expected that GIS-based applications will apply diversify into sustainable tourism planning and management.

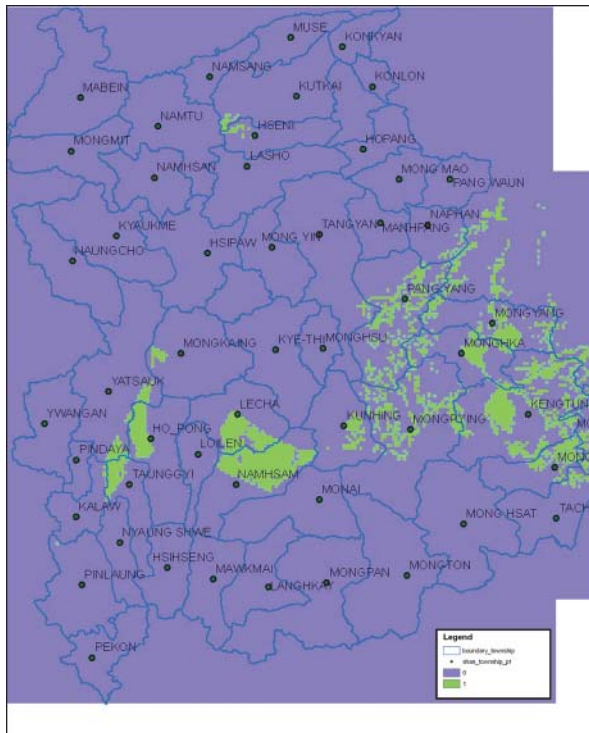

Figure 10.5: Bird habitat status in Myanmar

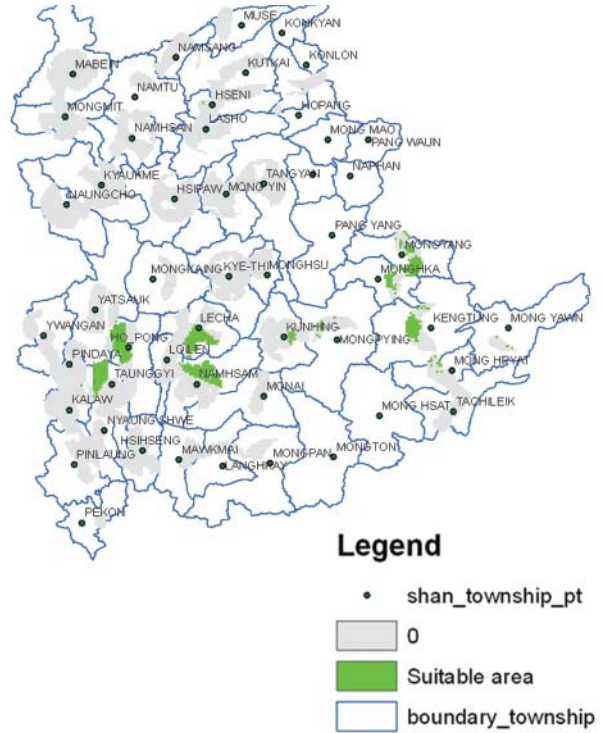

Figure 10.6: Suitability map for tourism in Myanmar

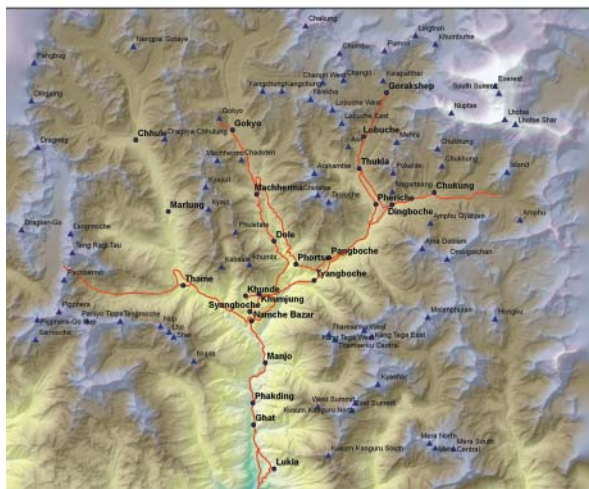

Figure 10.7: Finding the peaks in Sagarmatha National Park

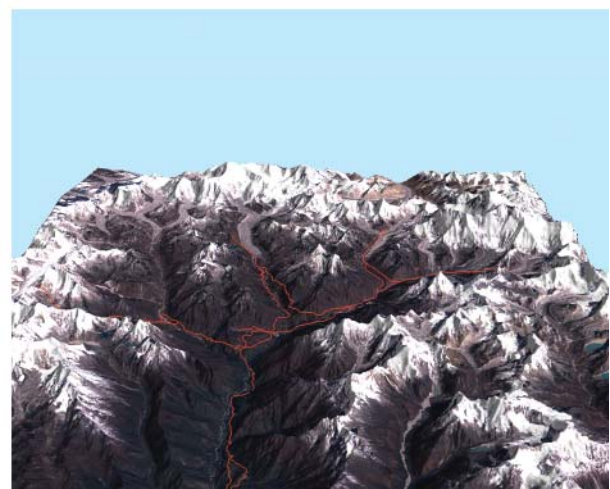

Figure 10.8: Finding the trails in Sagarmatha National Park

Chapter 11

Monitoring and Evaluation

This chapter covers

- The importance of monitoring and evaluation, and their application in sustainable mountain tourism (major steps, tools, and methods)
- The basic steps in monitoring community-based sustainable mountain tourism and how related projects and programmes can be evaluated

Introduction: The Need for Monitoring and Evaluation

Monitoring and evaluation (M & E) as a concept in project management is not new. The need for monitoring and evaluation in all development projects and programmes, including tourism, has been acknowledged as an essential element of the project cycle. Growing concerns over tourism impacts on the natural, social, and cultural environment, and the question of achieving sustainable and pro-poor development, however, have made monitoring and evaluation even more crucial in tourism management. The monitoring and evaluation of many development projects, including tourism, are often constrained by weak interest and commitment from donors, government, and civil society organisations. In addition, a weak culture in the context of sharing and using the results of evaluations among donors, implementers, and other stakeholders further hampers the functioning and objectives of M & E. Most tourism development projects do not give priority to M & E, but rather perceive the process as an add-on to their work which can be carried out whenever and wherever required by the project. In this way, projects often suffer, sometimes fail badly, and at other times succeed but without learning from either achievements or failures. The most dangerous and alarming situations arise when M & E systems are designed without proper consultation and participation of relevant stakeholders. This leads to the collection of irrelevant information, wastage of resources, and, ultimately, no clues about a project's successes and failures.

For the last few years, however, there has been increased interest by donors, governments, and civil society organisations in strengthening M & E systems, both at organisational and project levels. The need for an appropriate M & E system in sustainable tourism is increasingly realised at all levels, providing an opportunity to carry forward action plans with proper directions and with continuous modifications, amendments, and adjustments. This helps organisations, donors, and project managers to improve their performance, transparency, accountability, and learning from the implementation process and post-project scenarios.

To summarise, monitoring and evaluation activities are indispensable for a number of reasons:

- To understand the direction of identified plans; resource allocation versus performance (outputs), creating accountability and transparency; and to take immediate corrective action based on solid information
- To provide useful feedback to stakeholders, including decision makers, on development impacts and outcomes

- To enable corporate learning and contribute to the body of knowledge on what works and what does not work and why (lessons learned)
- To verify and improve programme quality and management
- To identify successful strategies for extension, expansion, and replication
- To justify or validate programmes to donors, partners, and other constituencies

Definition of Monitoring and Evaluation

Monitoring: Monitoring is a kind of information gathering process to find out whether planned actions are properly implemented or not. Monitoring can be defined as “a continuing function that uses systematic collection of data on specified indicators to provide management and stakeholders of an ongoing development intervention with indications of the extent of progress and achievement of objectives and progress in the use of allocated funds” (OECD 2006). Monitoring has the following attributes:

- It tracks performance against what was planned by collecting and analysing data on the indicators established for monitoring and evaluation purposes.
- It provides continuous information on whether progress is being made towards achieving the expected outputs through record keeping and regular reporting systems.
- It looks at both programme processes and changes in conditions of target groups and institutions brought about by programme activities.
- It generates information that enhances learning from experience and improves decision making.

Evaluation: Evaluation is an assessment of the results of the implementation of a programme. It is a selective exercise that attempts to assess progress towards, and the achievement of, an outcome systematically and objectively. Evaluation is an exercise involving assessments, differing in scope and depth, carried out at several points in time in response to evolving needs for evaluative knowledge and learning during the effort to achieve an outcome (UNDP 2006). It is a periodic event that contains in-depth analysis of programme performance. It relies on data generated through monitoring activities, as well as information obtained from other sources (e.g., studies, research, in-depth interviews, focus group discussions, surveys, and so.). Evaluation can be done internally or externally. The main differences between monitoring and evaluation are summarised in Box 11.1.

Box 11.1: Main Differences between Monitoring and Evaluation

Monitoring	Evaluation
Continuous	Periodic
Keeps track , oversees, analyses, and documents progress	In-depth analysis; compares planned with actual achievements
Focuses on inputs, activities, outputs, implementation processes, continued relevance, likely results at outcome level	Focuses on outputs in relation to inputs, results in relation to cost, processes used to achieve results, overall relevance, impact, and sustainability
Answers what activities were implemented and results achieved	Answers why and how results were achieved; contributes to building theories and models for change
Alerts managers to problems and provides options for corrective actions	Provides managers with strategy and policy options
Self-assessment by programme managers, supervisors, community stakeholders, and donors	Internal and/or external analysis by programme managers, supervisors, community stakeholders, donors, and/or external evaluators

How to Monitor and Evaluate Tourism Projects and Programmes

Monitoring and evaluation always follow a systematic approach. M & E cannot be done on an ad hoc or 'when required' basis. Proper thinking is needed in the project design stage for M & E to decide what needs to be monitored, how can it be done, when is it required, and for whom is it needed? These questions will pave the way to set clear objectives, scope, and role for M & E. Once these questions are answered, a clear M & E system can be developed for a tourism project or programme.

There are different M & E methods that can be used in sustainable mountain tourism. The most important ones are given below. Within each method, different tools can be used (see Volume 2).

- Core M & E methods (stakeholder analyses and questionnaires, sample surveys, and case studies)
- Discussion methods for groups (brainstorming and role plays; see also Tool 1, Volume 2)
- Methods for spatially-distributed information (maps and transects; see also Chapter 10)
- Methods for time-based patterns of change (diaries, photographs, and videos)
- Methods for analysing relationships and linkages (impact flow diagrams and problem trees)
- Methods for ranking and prioritising (matrices)
- Participatory M & E tools (participatory rural and rapid appraisals (PRA), rapid rural appraisal and the most significant change – also called the M & E method without indicators)

Requirements of an M & E system

There are six steps involved in designing an M & E system:

1. Establish the purpose and scope: why is M & E needed and how comprehensive should the M & E system be?
2. Identify performance questions, information needs, and indicators: what needs to be known to monitor and evaluate the project in order to manage it well?
3. Plan information gathering and organisation: how will the required information be gathered and organised?
4. Plan critical reflection processes and events: how will sense be made of the information gathered and how will it be used to make improvements?
5. Plan for quality communication and reporting: how and to whom needs to be communicated what in terms of the project activities and processes?
6. Plan for the necessary conditions and capacities: what is needed to ensure that the M & E system actually works?

Programme logic model

A programme logic model provides clarity to the monitoring teams in order to assess the M & E mechanisms linked to the programme model. This model is very useful for both the design and evaluation of M & E systems and programme inter-relationships. An example of a programme logic model in tourism is given in Figure 11.1.

Development of a logical framework approach (LFA)

The logical framework approach (LFA) was first used in the 1960s by the United States Agency for International Development and since then has spread widely throughout the world. Most donors now use the LFA method in their programmes and recommend their partners to follow their example. Used correctly, the LFA method is an instrument for reaching agreement on problems and objectives and the types of activities necessary for the achievement of a desired change. It is an instrument for making plans, analyses, assessments, follow-up, and evaluation of projects or programmes.

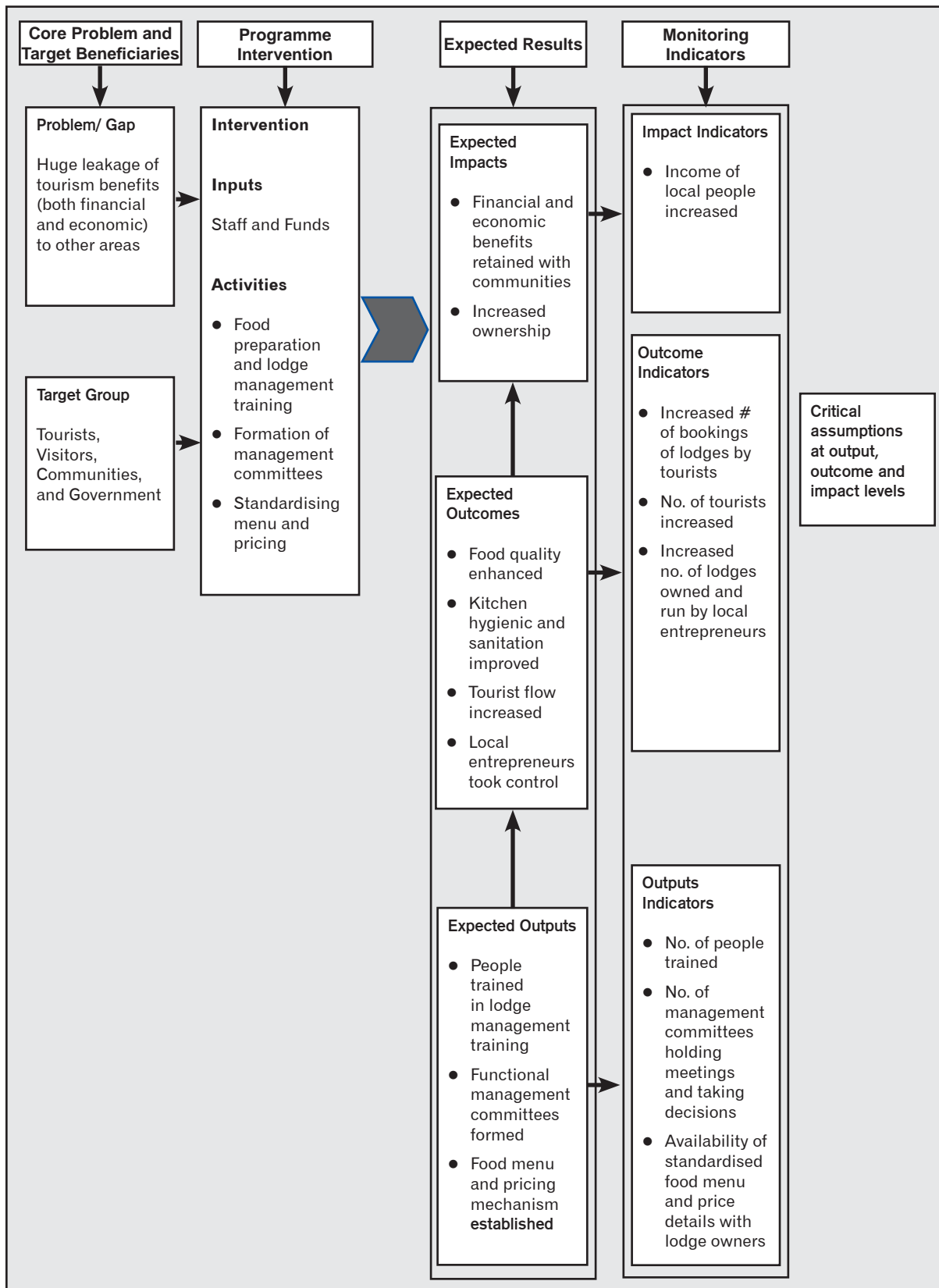

Figure 11.1: Logical model related to economic leakages in the tourism industry

The method should be used flexibly and be adapted to the problem to be solved. The LFA method consists of nine steps:

Step 1: Analysis of the project context

Step 2: Stakeholder analysis

Step 3: Problem analysis or situation analysis

Step 4: Objectives' analysis

Step 5: Plan of activities

Step 6: Resource planning

Step 7: Indicators or measurements of objectives

Step 8: Risk analysis and risk management

Step 9: Analysis of assumptions

The different stages do not need to be completed in succession one by one. Each step may need to be revised and adjusted during the course of the tourism project. If the LFA method is to function as an instrument for tourism management and control, it is essential that those who are affected by the project also assume responsibility for implementing the change. For example, it is important that those who will be affected by the tourism project participate in identifying the problems and formulating the objectives.

Steps 1-4 in the LFA analysis aim to ensure that the tourism project solves a problem that is important for the target group and that the causes of the problem are tackled.

Steps 5-7 aim to establish that it is possible to implement the tourism project and that the resources are sufficient to achieve the goals.

Steps 8-9 help to assess whether the tourism project will be able to continue without external support and whether the effects of the project will be permanent.

LFA workshops are usually held to obtain the views of different stakeholders on the problems that the project intends to solve and to reach agreement on the means and the objectives (Örtengren 2004). A detailed overview of the different steps in an LFA is given in Volume 2 (see Tool 29).

Evaluation in Tourism Project Cycles

In a tourism project cycle, four different types of evaluation can be distinguished: **formative, process, outcome, and impact evaluations.**

Formative evaluation

Formative evaluation is conducted in the design phase of a tourism programme to identify and resolve intervention and evaluation issues before the tourism programme is implemented. It identifies the intervention dynamics, assists in identifying effective interventions, and helps define realistic goals. It is carried out in the tourism planning phase and provides information about whether a programme design or implementation can be improved. This form of evaluation is useful as a way to ensure that the assumptions and logic used in the tourism planning process have been addressed thoroughly.

Example of a formative evaluation question: "Have promotional or educational materials been developed to showcase or conserve the different cultural assets of a programme's target population?"

Process evaluation

Process evaluation involves the assessment of the tourism programme or project's content, scope, or coverage together with the quality of implementation. If the process evaluation finds that the

programme or project has not been implemented, or is not reaching its intended target group, it is not worth conducting an outcome evaluation. This evaluation is conducted in the tourism implementation phase and provides information on whether or not the intervention is being implemented as intended.

Example of a process evaluation question: “How many of the individuals that are using the tourism programme’s services are from the programme’s target population (like communities, porters, trekking guides, tour operators, and so forth)?”

Outcome evaluation

Outcome evaluation is designed to attribute changes to the tourism intervention. At the very least, the evaluation design has to be able to plausibly link the observed outcomes to the tourism programme or project, and to demonstrate that changes are not the result of non-programme or project factors. An outcome evaluation is conducted immediately after the conclusion of the tourism programme (activity) or programme cycle. It answers questions about whether the intervention is producing the predicted changes in the target group, system, or policies or is achieving its stated objectives. This evaluation is useful when preliminary results on a tourism programme’s impact on behaviour, knowledge, attitudes, access, policy, or other identified short-term outcomes are needed or when limited resources and/or interest prevent a long-term evaluation.

Example of an outcome evaluation question: “Is a programme aiming to increase the incomes of porters, significantly increasing the use of tourism products in the Himalayan region?”

Impact evaluation

Impact evaluation determines if the results or outcomes of the tourism programme are evident over the long run. It assesses the overall or net effects of a programme, intended and unintended. Impact evaluation is very rare and quite costly. Comparing monitoring impact indicators with process and outcome evaluations is often considered sufficient to indicate the overall impact. An impact evaluation provides information on whether or not the programme has been effective or achieved sustainable impacts. The results from an impact evaluation are used for policy and funding decisions, or to identify successful interventions to inform other research and programmes.

Example of an impact evaluation question: “Did increased incomes from tourism result in greater enrollment of children in school?”

Monitoring Sustainable Mountain Tourism

There is an ever-increasing realisation of the need to empower stakeholders at all levels during all stages of the tourism project cycle. Participatory development tools and techniques provide an immense opportunity to bring all stakeholders and beneficiaries on to a platform where they can influence the process of change in their lives in their own way. The participation of stakeholders in tourism project management not only empowers them, but also ensures ownership and the sustainability of the tourism intervention.

Participatory monitoring is a systemic exercise, carried out with the careful facilitation and involvement of stakeholders, which generates reliable information on different aspects of the tourism project. This section (mostly based on SNV Asia pro-poor sustainable tourism forthcoming) examines practical steps for setting up and running a participatory monitoring programme and provides a brief introduction to some of the main monitoring considerations, including the following:

- Examining the rationale for monitoring in community-based sustainable mountain tourism
- Thinking about the type of indicators to be used
- Considering how to communicate monitoring results to stakeholders

Examining the rationale for monitoring

Setting-up and running a tourism monitoring programme can be a time-consuming and costly undertaking. Effective monitoring requires significant and ongoing commitment from stakeholders. The importance of monitoring and the value of the information to particular groups of stakeholders need to be clearly understood prior to starting out, if a tourism programme or project is to gain stakeholder support and be successful. Reasons why different stakeholders might support the monitoring of sustainable mountain tourism projects include the following:

- Community members with a financial stake in the project will want to know how the project is performing and what can be done to improve operations.
- Project donors may be particularly interested in the impact of the project on their target group.
- Non-profit organisations may be interested in the impact of the project on their particular area of concern, such as poverty reduction or biodiversity conservation.
- Local governments will want to know how the project is performing and what might be done to reproduce successes or avoid failures elsewhere.
- National governments may be interested in highlighting case studies of successful community-based tourism through international awards and recognition.

Types of indicators to be used

There are three main types of indicators: qualitative, quantitative, and normative:

- **Qualitative indicators** rely on value-based assessments (what people think) of the state of a particular issue such as residents' views on tourists, tourists' level of satisfaction, or experts' descriptions of the state of a particular tourist attraction.
- **Quantitative indicators** are focused on specific, measurable facts. They involve the counting of specific events in a scientific fashion. These are normally expressed as percentages (e.g., 20% of guides are certified), ratios (e.g., the ratio of residents to tourists), or as raw data (e.g., 900 litres of water used per guest night).
- **Normative indicators** measure the existence or non-existence of some element, such as a tourism plan or an environmental policy. These are less useful in terms of sustainability unless they are linked to other indicators that measure how effective the plans or policies are.

In addition to these divisions, UNWTO (2004) highlights the following types of indicators:

- Early-warning indicators (e.g., decline in the number of repeat visitors)
- Indicators of system stress (e.g., water shortages, and crime incidents)
- Measures of the current state of the industry (e.g., occupancy rates, number of employees)
- Measures of the impact of tourism development on the biophysical and socioeconomic environment (e.g., levels of pollution, congestion, loss of cultural heritage, income for local communities)
- Measures of management response (e.g., number of tourism awareness programmes run, guides trained, cultural sites restored)

Box 11.2 shares the experiences of communities with community-based mountain tourism monitoring processes in Corbett National Park, Uttarkhand, India, and how they related to different indicators that were set for the project. Indicators of sustainability should be defined at an early stage in the process of formulating a tourism strategy for a destination. They can then be used for (UNEP/ UNWTO 2005)

1. baseline assessment of conditions and needs;
2. setting of targets for policies and action;
3. assessment of actions; and
4. evaluation, review, and modification of policies.

Box 11.2: Experiences in Community-based Mountain Tourism Monitoring – Lessons Learned from Corbett National Park, Uttarakhand, India

As part of the project for Leadership for Environment and Sustainable Development (LEAD) Fellows in Uttarakhand Province, a community-based tourism project was developed in Corbett National Park over a three-year period from January 2001 to November 2003. At the conclusion of the project, results were analysed by LEAD Fellows with project partners and beneficiaries using participatory methods. As a result of the use of the indicators at the planning, product development, and evaluation stage there was an increase in understanding of tourism issues amongst the villagers. Furthermore, the use of indicators provided the project team with information for planning and data for communicating results. However, the process was constrained by several limitations.

The CBT plans had clear objectives, but they were not specific enough to be measured. In the end, it was not possible to develop specific objectives when working with communities because of their limited understanding of tourism issues, lack of consensus within the community itself, and the evolutionary nature of the process.

Communities were more comfortable with qualitative indicators and with relative exercises such as ranking, rather than measurable indicators. For example, in the trend lines used as part of the discovery phase of an APPA exercise (see Chapter 6), variations in the number of tourist arrivals, or number of vehicles, were portrayed with ease. However, it was difficult for the community to specify the exact number as recording arrivals and movements required tools, time, and resources. Trend lines developed during the discovery phase were used for the dream phase by making projections into the future on what the villagers would like to see, and they could also be used as a monitoring baseline.

Lastly, communities were able to work only with a limited number of indicators and it was helpful to prioritise indicators as per the feasibility and convenience of the villagers themselves. Dealing with too many variables constrained their understanding. The indicators chosen by different villages differed. It is necessary to permit site-specific selection of indicators.

Source: Adapted from UNWTO 2004

Indicators are intimately connected with the concept of limits of acceptable change; (see also Chapter 4). Indicators or standards used in tourism must set the limits of acceptable change for the tourism development process. Some impacts are inevitable, but managers must be willing to say how much impact they will tolerate before changing the way they are managing a tourism destination or site. If trails erode faster than it is feasible to maintain, if nature viewing areas are getting too big, if some animals are changing their behaviour in an unacceptable way, then management actions must be taken (e.g., increase fees, reduce group sizes, put up fences, increase patrols).

Establishing standards requires taking the indicators from the previous step and placing a quantitative value on them: e.g., two landslides per year; 90 per cent of visitors were 'very satisfied'; two new tourism entrepreneurs per year in a community; 25 individual Monarch butterflies sighted along trail between 10 and 11am on 20 July. These quantitative values represent limits that are acceptable. If fewer than 90 per cent of visitors were 'very satisfied' or fewer than 25 butterflies were sighted along a given trail at a given time, then managers must determine what is wrong and work to fix it. Establishing indicator standards should involve as many stakeholders as possible so that the standards agreed upon represent everyone's best faith effort and so that they will commit to trying to achieve these limits (Adapted from Drumm et al. 2004).

The decision about what type of indicators to use is influenced by the scope of the project that is to be monitored, the needs of the stakeholders involved, and the human and financial resources available to the project. Regular monitoring of changes in environmental, social, or cultural conditions using indicators can allow for an adaptive management approach that is more flexible than the heavy use

of regulation. It is normal for a wide range of possible indicators to be identified initially – especially when developed in a multi-stakeholder context – which may then be refined according to relevance and practicality.

Developing a community-based mountain tourism monitoring system

Monitoring the sustainability of community-based mountain tourism involves taking measurements of environmental, social, and economic conditions using the selected indicators. There are many different processes that can be used to develop a mountain tourism monitoring system. Here the monitoring process is given in three main phases: i) planning and development (Steps 1-3); ii) monitoring and analysis (Steps 4-5); and iii) implementation and review (Steps 6-8). This sequence can be applied to most destinations and adapted to suit local circumstances (Figure 11.2).

During the planning and development phase, key decisions need to be made about the objectives of the tourism programme; for instance, who will do the monitoring, what the spatial boundaries of the monitoring area will be, and what timeframe the programme will follow. The monitoring and evaluation phase concerns the collection of monitoring data, the analysis of results, and the establishment of indicator thresholds. The implementation and review phase involves deciding on actions to address areas of poor performance, communicating with stakeholders, and reviewing and improving the monitoring programme prior to re-monitoring. This section examines all three of these phases divided into eight distinct steps (shown in Box 11.3). Each step is explained in more detail in Volume 2.

Experiences in community-based tourism monitoring show (UNWTO 2004) that communities often come up with indicators spontaneously as part of the tourism planning process and in tourism product development processes. These indicators may be both quantitative as well as qualitative. In the early stages of the project they are more likely to be satisfied with indicators connected with

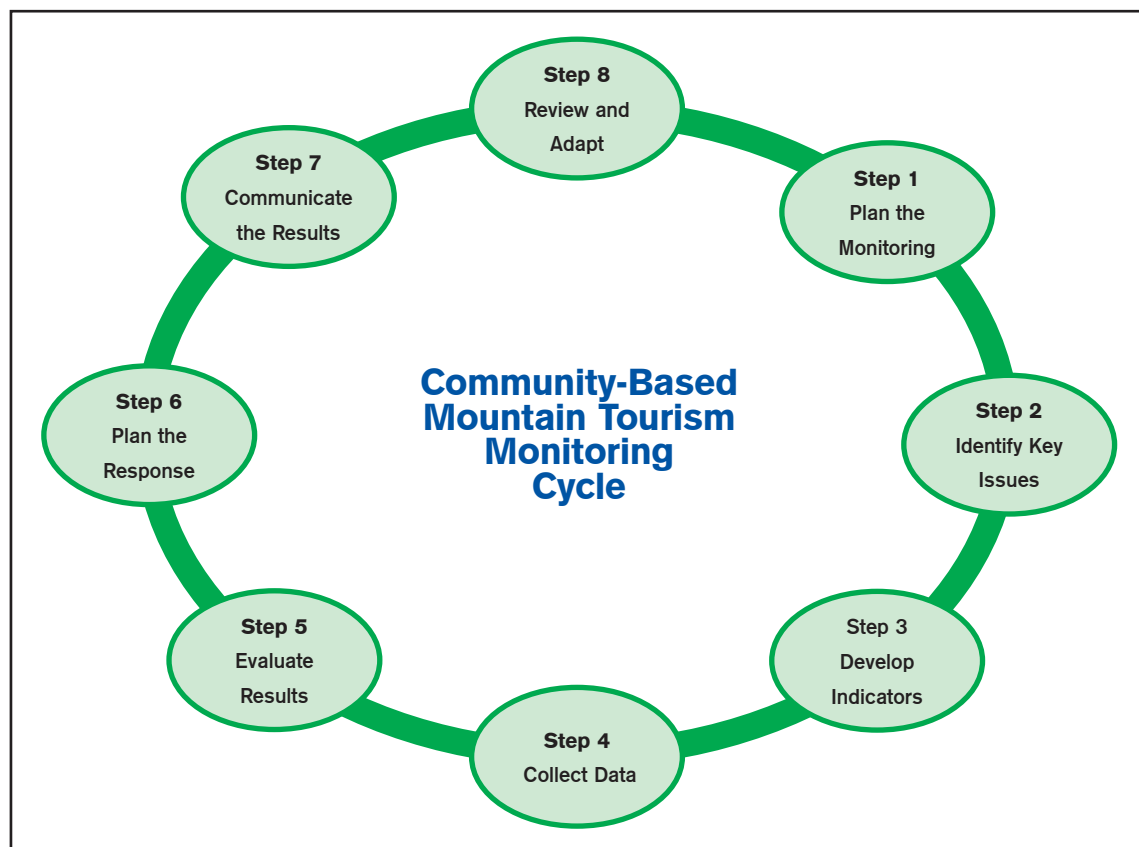

Figure 11.2: Steps in the development of a community-based mountain tourism monitoring system

Box 11.3: Eight Steps for Monitoring Community-based Sustainable Mountain Tourism Projects

Step	Process
Planning to Monitor	<ul style="list-style-type: none"> ● Discuss and plan the idea of monitoring with the community ● Set objectives for monitoring ● Discuss general practical issues such as who will be involved, the boundaries of the study area, the resources required, and timing for monitoring
Scoping Key Issues	<ul style="list-style-type: none"> ● Research key issues facing the community-based tourism business and community ● Hold community meeting to review and prioritise issues ● Seek input of monitoring working group to finalise list
Developing Indicators	<ul style="list-style-type: none"> ● Review long list of existing indicators to match these with the key issues ● Brainstorm in small groups to find new indicators to match issues. ● Screen potential indicators using simple screening questions ● Fine-tune indicators with technical expertise where necessary
Collecting Data	<ul style="list-style-type: none"> ● Identify data sources ● Design data collection methods such as surveys and questionnaires ● Design a simple database to hold the results
Evaluating Results	<ul style="list-style-type: none"> ● Establish year-one benchmarks ● Identify appropriate thresholds for management response
Planning the Response	<ul style="list-style-type: none"> ● Identify poor performing indicator areas ● Research possible causes for poor performance ● Decide on a management response ● Draw up an action plan
Communicating Results	<ul style="list-style-type: none"> ● Design communication methods for different stakeholder groups ● Publish results and update regularly
Reviewing and Adapting	<ul style="list-style-type: none"> ● Review objectives and key issues ● Review indicators and data collection ● Review management responses

visitor arrivals, sales, and important features of nature, culture, and wildlife. As the project advances, however, capacities need to be developed to set targets, maintain records, and carry out participatory evaluation so as to develop common appreciation and identify future actions.

The factors influencing a successful monitoring programme can be summarised as follows based on helpful tips from a successful community-based tourism planning and monitoring system in Australia (see Miller and Twining-Ward 2005).

Indicators

- Ensure that data are collected in an appropriate and consistent manner. Data are only of value if they can be applied and used by others.
- Review existing data collection systems to see how they can be applied. Do not reinvent the wheel.

- Review indicators on a regular basis for relevance to both the destination and audience needs.
- Integrate monitoring data into existing information systems.
- Align indicators and data collection processes with other models where applicable so that a global comparative study may be possible.
- Ensure that the development of indicators meets the long-term needs of the community, not just of the funding agencies.
- Ensure stakeholder involvement.
- Communicate the findings in a format and language understood by the intended audience.
- Establish a marketing budget to enable the production of promotional tools such as a website, posters, fliers, news articles, and conference papers.
- Do not try to engage everyone at the same time; identify target markets and work towards engaging the entire community in the long-term.
- Work collaboratively and collectively with government and non-government agencies and community groups to ensure a mutually beneficial approach for all involved.
- Demonstrate how people can become involved in the process; detail what they can do to help.

Human Resources

- Recognise the signs of burnout of key project drivers; provide support.
- Ensure some continuity of key individuals, especially on the management committee, to maintain institutional memory that will, in turn, ensure that the process remains on track.
- Appoint staff, advisors, and management committee members with the passion, interest, and willingness to invest their time in seeing the process succeed.

Governance

- Independence of a board or management committee is important in terms of its ability to comment on issues relating to the status of tourism.
- Agencies and partners have to believe in the long-term process and articulate this belief within the public arena.
- People will always question if the process is working; project managers need to demonstrate that the process runs through a natural life-cycle. Urge stakeholders not to lose confidence when stagnation hits.
- Cultural change amongst government agencies, communities, and individuals takes time; do not worry if integration into management practice does not happen immediately. Remember, this is a long-term process.

Funding

- Access to sufficient resources to implement action projects may demand a great deal of time and energy.
- Think creatively, commercially, and collectively regarding funding arrangements to ensure the implementation of project activities. Traditional funding sources may not be sufficient to maintain operational costs in the long term.
- Develop a business plan and funding outline.
- Encourage government agencies to allocate funding for monitoring as a standard operational cost rather than through annual funding rounds.

Box 11.4 illustrates the monitoring process used by the Tourism for Poverty Alleviation Programme (TRPAP), Nepal.

Box 11.4: Monitoring at TRPAP: Nepal

Name of project	Tourism for Rural Poverty Alleviation Programme (TRPAP) NEP/99/013
Responsible Organisation	Ministry of Culture, Tourism, and Civil Aviation (MoCTCA) Financial and technical assistance from UNDP, DFID, and SNV-Nepal
Cooperating Organisations	Ministry of Local Development and District Development Committees (DDCs); Nepal Tourism Board (NTB) Department of National Parks and Wildlife Conservation (DNPWC) Trekking Agents Association of Nepal (TAAN) National Academy of Tourism and Hospitality Management Nepal Mountaineering Association (NMA) Nepal Association of Travel and Tour Agencies (NATTA)
Project Site	Six areas covering major tourism destinations in Nepal, namely Taplejung (Kangchenjunga region), Solukhumbu (Everest region), Rasuwa (Langtang region), Dolpa, Rupandehi (Lumbini area), and Chitwan
Project Goals and Objectives	<ul style="list-style-type: none"> ● To demonstrate successful sustainable tourism development models ● To develop institutional mechanisms to improve the management of tourism in Nepal ● To help the government review and formulate sustainable tourism development policies and strategies and integrate them into wider conservation objectives
Key Project Activities	<p>Social Mobilisation</p> <ul style="list-style-type: none"> ● Community organisations (COs) have been formed and APPA planning exercises undertaken. ● A Sustainable Tourism Development Unit has been formed within the Nepal Tourism Board (NTB). ● Sustainable tourism development committees have been formed at the village level to manage rural tourism through the COs. ● A tourism unit has been set up within the park office. ● Buffer zone management committees have been strengthened to manage tourism within the area of park and buffer zones. <p>Human Resource Development</p> <ul style="list-style-type: none"> ● Support has been given to central-level tourism institutions to develop their capacity to identify rural tourism opportunities and develop tourism plans. ● Local residents in COs and functional groups (FGs) have been trained in areas related to tourism and enterprises such as small hotel and lodge management, homestay management, trek guiding, and organic farming. ● Tourism and environment awareness programmes have been conducted for the members of COs, FGs, and students. <p>Tourism Infrastructure Development</p> <ul style="list-style-type: none"> ● Maintenance and construction of a wide range of tourism infrastructure has taken place including trails, bridges, information centres, and resting places; the renovation of religious artefacts; fixing of signs and information boards; the provision of dustbins; construction of dumping sites, incinerators, improved cooking stoves, and private and public toilets. <p>Entrepreneurship</p> <ul style="list-style-type: none"> ● A venture capital fund has been set up to provide soft loans from a revolving fund established at the village level to the members of COs and FGs to start new enterprises or upgrade existing ones. ● Efforts have been made to promote and market newly-developed rural tourism products through the development of print and electronic media, participation in international trade fairs such as ITB Berlin (an international convention on innovations in tourism and trade held annually), and organising familiarisation trips for tour operators, hoteliers, tour and trekking agents, and tourism journalists.

Box 11.4: (cont...)

<p>Key Project Activities (cont...)</p>	<p>Planning and Management</p> <ul style="list-style-type: none"> ● A national tourism strategy and tourism marketing plan for Nepal has been developed in collaboration with all the stakeholders including the government, private sector, and local community representatives. ● Five district tourism plans have been developed (Taplejung, Rasuwa, Dolpa, Chitwan, and Rupandehi). ● A plan for management of tourism in Sagarmatha National Park has been prepared to help manage tourism within the park on a sustainable basis.
<p>Suggested Indicators</p>	<p>Tourism Activities/Services</p> <ul style="list-style-type: none"> ● Percentage of guides who are local to the area they are guiding in ● Percentage of local/outside running hotels, guest houses, and lodges <p>Enterprises</p> <ul style="list-style-type: none"> ● Percentage of foodstuff used by tourist accommodation that can be sourced locally ● Number of local residents taking advantage of micro-credit schemes ● Change in number of small agri-businesses supplying the tourism industry ● Change in number of local residents engaged in the sale of handicrafts <p>Culture</p> <ul style="list-style-type: none"> ● Change in frequency and number of local residents participating in or attending traditional dance performances <p>Health and Sanitation</p> <ul style="list-style-type: none"> ● Percentage of households with regular garbage collection ● Percentage of households with clean energy systems ● Percentage of households with access to clean water <p>Institutional Strengthening</p> <ul style="list-style-type: none"> ● Percentage of households who feel they are involved in tourism decision making ● Diversity of participation at CO meetings ● Number of COs with successful participatory mechanisms in place ● Number of local residents who have participated in APPA workshops ● Number of school children who have participated in awareness programmes
<p>Project Outcomes</p>	<ul style="list-style-type: none"> ● 30 VDCs (out of total of 48) have established a sustainable tourism development committee (STDC). ● Over 635 COs can now manage their institutions and perform regular functions like book-keeping and communication as well as participatory decision making. ● A network of more than 2,800 local entrepreneurs belonging to 200 FGs has been established to share experiences about enterprises. ● Over 360 APPA workshops have been conducted in programme areas. ● Over 24,000 local stakeholders, including school children, have been made aware of environment conservation issues. ● Over 7,400 people (local stakeholders such as VDCs, STDCs, STDS, DDCs, and COs) were trained to provide various tourism-related services. ● Over 470 micro-enterprises have been started and upgraded with the soft loans provided by the programme in the districts. ● Promotional materials such as postcards, brochures, posters, and documentaries have been developed and distributed to the private sector.

Part 4

**Issues and Trends
in Institutional
Development**

Chapter 12

Public-Private Partnerships in Tourism Clusters

This chapter covers

- The main stakeholders in sustainable mountain tourism
- The different areas for collaboration between the public and private sector
- The roles and responsibilities of NTOs and STOs in this process
- The cluster approach and the linkages between the different stakeholders

Introduction: Stakeholders in Sustainable Mountain Tourism

Pro-poor sustainable mountain tourism development needs a diversity of actions undertaken at the village level through to the national and international levels. Such actions include product development, marketing, planning, policy, and investment. Sustainable tourism development requires an integrated and holistic approach to the entire tourism system. Several stakeholders with a broader mandate than tourism development are involved and are quite often critical to sustainable development. A driving force for sustainable mountain tourism can be useful to get the different stakeholders working together. Sustainable mountain tourism can be incorporated into the tourism development strategies of governments and businesses.

Broader policy frameworks and initiatives outside tourism, such as policies on land tenure, micro and small enterprise development, and representative governments, are also key. Such policy frameworks and initiatives result in a range of stakeholders with specific, but sometimes changing, roles and responsibilities in the development of sustainable mountain tourism. This chapter introduces different stakeholders and the role of NTOs and STOs in development of clusters of sustainable mountain tourism (adapted UNWTO 2000).

Role of private sector, governments, civil society, and donor agencies

Government, the private sector, non-government organisations (NGOs), community organisations, and the poor all have critical and very different roles to play in pro-poor sustainable mountain tourism. The private sector can be directly involved in partnerships. The tourism industry should participate in product and market development to ensure commercial viability, but can be involved in every aspect of development of sustainable mountain tourism. There is much that governments can do and if the government takes a leading role in sustainable mountain tourism it can be of great advantage. At a minimum, there needs to be a policy environment that facilitates sustainable mountain tourism development and which contributes to poverty reduction.

The poor are critical to the success of sustainable mountain tourism, but they often need support to be organised at the community level in order to engage effectively in tourism. It is invaluable to have a third party to support efforts in sustainable mountain tourism – this is often, although not always, a role for a non-government organisation. Donors, through their role in supporting tourism initiatives, and the ‘sustainable tourism’ agenda, can promote the sustainable mountain tourism concept and its consequent interventions. A summary of the roles of the main stakeholder groups is given below (Roe and Urquhart 2001).

The **private sector** can do the following:

- Talk to local people to explore options – this could form part of a systematic supply chain analysis.
- Maximise use of local suppliers and local staff.
- Provide technical advice to local tourism enterprises, market them, take tourists, and provide feedback.
- Establish a business partnership with residents, e.g., equity sharing, concession arrangements.
- Share or develop infrastructure (roads, water), key equipment (telephones, radio), or services (health care).
- Respect and promote local guidelines and norms.
- Help boost the understanding of the poor and others (including government and NGOs) about pro-poor sustainable tourism development.
- Explain to customers and suppliers (e.g., international operators and tourists) why pro-poor commitments matter and what more they can do.

Governments can do the following:

- Consult with poor residents when making decisions about tourism.
- Provide secure tenure for the poor over tourism land and assets.
- Use planning controls and investment incentives to encourage private operators to make and implement pro-poor commitments within a framework of broader sustainability.
- Encourage the dispersion of tourism to poor areas through infrastructural investment and marketing. This needs to take place as part of an integrated and sustainable approach to rural and urban development.
- Ensure good policy is followed by implementation by linking policies to budgeting cycles and building sufficient implementation capacity at the appropriate levels of government, as well as by devolving resources.
- Promote pro-poor enterprises and products in national marketing materials.
- Revise regulations that impede the poor in employment or small business.
- Integrate awareness of sustainable mountain tourism into pro-poor growth strategies and small enterprise strategies.

Civil society can do the following:

- Act as a catalyst and liaise between stakeholders.
- Invest in training, capacity building, and technical assistance for the poor to increase their understanding of the tourism industry and to develop their skills for small business and tourism employment.
- Explore options for linkages between private operators and poor suppliers; facilitate the process to reduce time and risk for both of them.
- Develop processes that amplify the voice of the poor at the policy level.
- Help avoid raising unrealistic expectations among the poor.
- Support campaigns that aim to enhance the pro-poor objectives of tourism.
- Push for the inclusion of pro-poor objectives within multilateral trade relations.

Donor agencies can do the following:

- When supporting tourism development, require assessment of pro-poor and sustainability issues.

- Ensure that tourism consultants are aware of pro-poor and sustainability issues and are required to address them, given their considerable influence on tourism national plans.
- When supporting growth or anti-poverty strategies in specific areas where tourism exists, ensure that the pro-poor potential and sustainability of tourism is assessed.
- Promote pro-poor sustainable tourism within the international development agenda, with governments, and industry, particularly by emphasising redistribution of socioeconomic benefits that is a pro-poor and focuses on sustainable mountain tourism development.

The roles and responsibilities of stakeholder groups inevitably change as a country's tourism industry develops. A UNWTO Business Council study concluded that, traditionally, the burden of leadership and responsibility is on the shoulders of the public sector when tourism development is in its infancy. As tourism in the destination develops, this burden of responsibility is gradually transferred to the private sector. In the public-private partnerships of the future, however, the study concludes that the balance of responsibility will swing gently back to the middle. Both the public and private sectors will share responsibility within the partnership for the development and management of tourism in a way that is economically, socially, culturally, and environmentally sustainable. The role of governments (especially national tourism administrations), how the private sector was and is involved in tourism development, and how public-private partnerships emerged are discussed below (UNWTO 2000).

Role of NTOs/STOs

Governments have traditionally played a key role in the development of tourism and in the promotion of their countries as tourism destinations. Their role is clearly more important in developing countries and in countries in which tourism is in a transitional stage in which support can be crucial to trigger growth.

It is generally recognised that for tourism to develop in a sustainable manner an appropriate physical, regulatory, fiscal, and social framework is required. This is something that can, of course, only be provided by governments, or public sector local authorities. Governments also usually provide the basic physical infrastructure necessary for tourism – such as roads, airports, and communications – and create the legal framework within which the industry operates. This helps to explain why few national governments or central administrations have any serious doubts as to the rationale for their continued involvement in tourism generally. There have been, however, increasing signs of state disengagement from tourism over the last decade – and not just in the most developed countries. This has resulted in the relinquishing of a number of their traditional responsibilities and activities in the field of tourism in favour of both provincial or state and local authorities and, more particularly, the private sector.

The publication 'Towards New Forms of Public-Private Sector Partnership' (UNWTO 1997) analyses the changing role, structure, and activities of national tourism administrations (NTAs) in 22 countries. The report concludes that, in the early years of tourism development, NTAs not only developed their countries' tourism facilities, but also were responsible for running them. They became hoteliers, travel agents, and tour and transport operators. In addition, the powers invested by governments in their NTAs in those early days were very broad, encompassing all areas of tourism activity, including hotel development and financing.

As tourism started to grow, its potential commercial value was enhanced. The private sector became increasingly interested in the business opportunities it offered. This resulted in a boom in hotel development and the rapid expansion of travel agency and tour operations. Before long there was excess capacity and cut-throat competition, which led, in some countries, to malpractices.

In order to moderate the growth of supply, and prevent or control malpractices, governments introduced legislation and the industry became increasingly regulated. Licensing of travel agencies and hotel classification became obligatory in most countries and price controls were widespread.

New taxes were imposed by governments to help recoup some of the public sector's initial investment in development of tourism infrastructure. In addition, as more and more people discovered the joys of foreign travel, foreign currency restrictions were introduced by some countries in an attempt to keep nationals at home and stem the growing deficit in their balance of payments. In many countries, this led to excessive legislation and an over-regulated industry.

The NTAs realised the problems caused by over regulation and excessive controls. In almost all the countries surveyed by UNWTO in the mid-1990s, governments had either divested themselves, or were in the process of divesting themselves, of their direct interests in tourism assets and services. This trend has since gained momentum. Industry legislation and regulation are less and less common, except where they relate to consumer protection, or to culture and heritage, or environmental conservation.

Since the turn of the century, NTAs increasingly have seen themselves as a unifying force, coordinating the efforts of the different public-private sector players in the industry. Policy and planning issues, for example, including those with impacts on employment and education, are addressed jointly with other government ministries and departments through inter-ministerial councils and committees and, in some countries, in consultation with the private sector.

Public-private sector collaboration

The main area in which public-private sector collaboration or partnerships in tourism have developed is marketing and promotion. In addition to easing budget constraints, governments also recognise that a public sector-led marketing organisation is often less entrepreneurial and effective than one managed by the industry itself, or in collaboration with the industry. As a result, they have been looking more and more to the private sector to take on an increasing share of the marketing and promotional functions traditionally assumed by government.

The results of the earlier UNWTO study (1997) showed that this has resulted in an increasing separation of marketing and promotions from other NTA functions and activities. In most of the countries surveyed, semi-public, NTOs and STOs have been established or recognised by the state as autonomous bodies with competence at the national level for the promotion (and, in some cases, marketing) of inbound international tourism. In countries with a high degree of decentralisation, the partnership involves not only central governments as the public partners, but also provincial and local authorities.

Private sector funding of national tourism promotion is growing annually as a proportion of NTAs' marketing and promotion budgets, although it is important to note that this proportion still represents a fairly modest share in many countries. Moreover, for the majority of NTAs, the private sector's contribution does not come as easily as one might imagine. Private sector funding is usually neither automatic, nor part of an NTA's or NTO's core budget. The bulk of partner funding, whether from local authorities or the private sector, has to be earned and, in some cases, bid for on a programme-by-programme, or campaign-by-campaign basis.

Although marketing and promotion is the most common area for public-private sector cooperation and more formal partnerships, it is by no means the only area of interest. Infrastructure and product development, education and training, and financing and investment are other areas in which cooperation between all stakeholders, and particularly between the government and the private sector, contribute to tourism growth and an increasingly competitive industry. In addition, there is growing evidence of the importance of cooperation in addressing key issues of concern such as safety and security, health, the environment, and culture and heritage.

Governments are increasingly calling on the private sector to manage state-owned operations such as airports, national heritage buildings, or public utilities. This makes sense because of the private sector's highly developed commercial sense and experience with business practice.

In summary, it can be said that public-private sector cooperation tends to be focused on four main areas: improving the **attractiveness** of a destination, **improving marketing efficiency**, **improving productivity**, and **improving the overall management** of the tourism system. These four main areas are the central elements of the tourism cluster model and they are the basis for a tourism cluster strategy. A tourism industry cluster can be defined as a group of companies that rely on an active set of relationships among themselves for individual efficiency and competitiveness. Figure 12.1 depicts this cluster approach.

The competitive strategy that is central to a tourism cluster, is oriented towards obtaining competitive advantages in every one of the sectors in which the cluster competes. Detailed steps on how to collaborate to improve the attractiveness, marketing, productivity, and management of a tourism destination in order to create these competitive advantages, are given in Volume 2 (Tool 3).

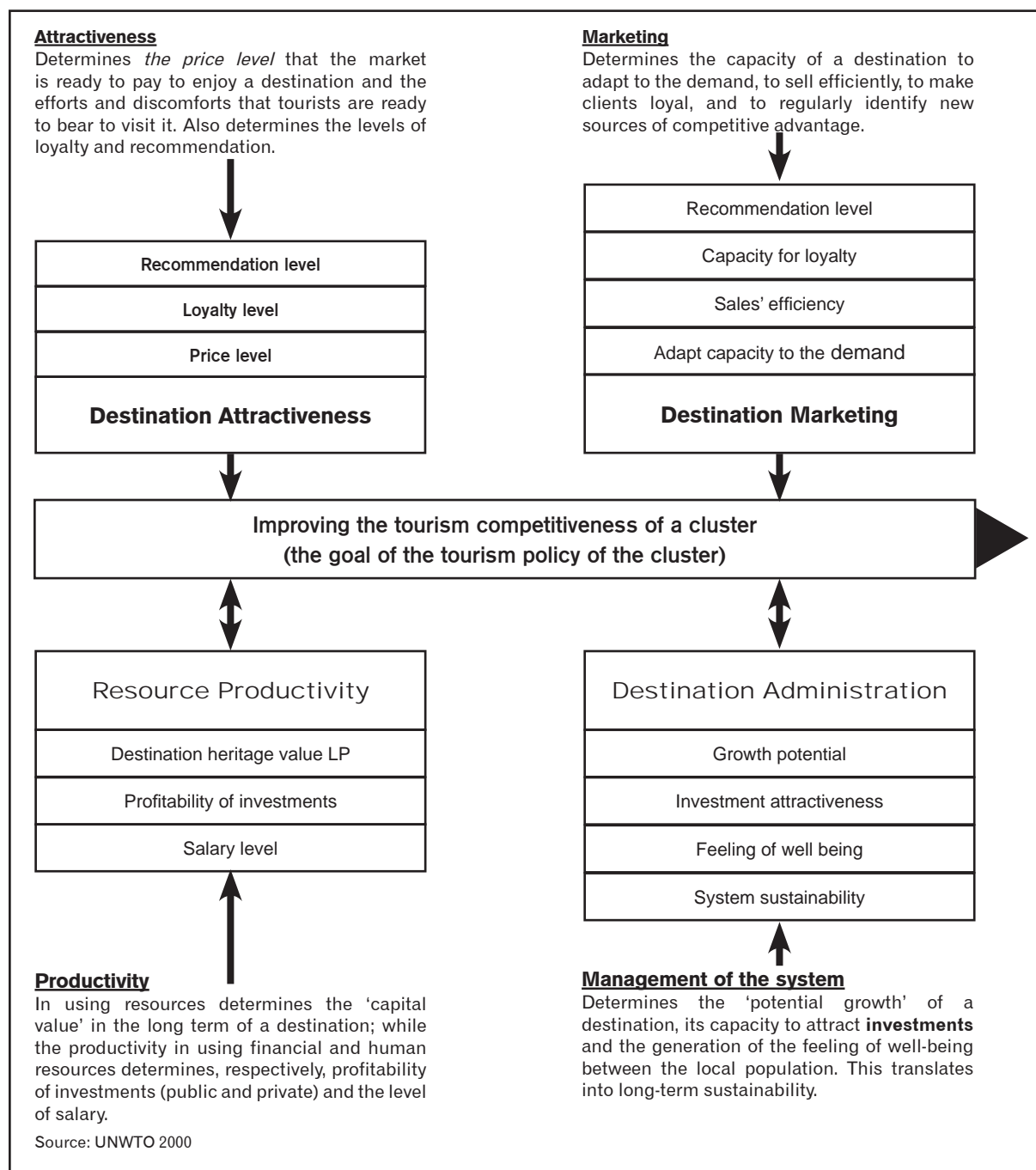

Figure 12.1: Attractiveness, marketing, productivity, management model approach for a tourism cluster

Major areas of public-private sector collaboration

Major areas of public-private sector collaboration include the following:

1. Product development and enhancement
 - Attractions and accommodation
 - Sustainability concerns
 - Setting quality standards
2. Infrastructure and human resources
 - Provision of basic services
 - Safety and security
 - Education and training
3. Marketing and promotion
 - Harnessing technology and improved marketing
4. Socioeconomic and geo-political factors
 - Leveraging finance

Strategic partnerships are identified as increasingly important because of the growing challenges facing the industry. The most important of these challenges are as follow:

- Changing market demand
- Increased competition from new and emerging tourism destinations
- The need to ensure sustainable tourism development
- Insufficient resources – both financial and human
- Harnessing technology

A detailed checklist identifying opportunities for public-private sector cooperation in tourism cluster development is given in Volume 2 (Tool 3).

Roles and responsibilities

The roles and responsibilities of the different stakeholder groups in public-private sector cooperation depend on local circumstances. Some generalisations, however, can be made about the roles of the public and private sector. Certain needs and tasks are identified for both the public and private sectors.

The **public sector** needs to

- Have a vision for tourism;
- Provide an enabling environment for tourism, i.e., one that supports sustainable and predictable profitability for the private sector, offering freedom for capital flows and facilitating market-driven investment;
- Ensure adequate infrastructural development and maintenance;
- Create sufficient open market conditions to stimulate sustainable tourism development;
- Provide support facilities and facilitation services for private enterprise, along with appropriate incentives and land policies;
- Ensure flexible labour laws to enable staff with key skills to be located where necessary;
- Guarantee stable regulations and fair taxation;
- Provide a regulatory framework in consultation with all interested stakeholders to protect and enhance natural, social, and cultural environments;
- Ensure the well-being of local communities and international and domestic visitors; and
- Undertake research in collaboration with the private sector to provide market information for the industry and the investment community and improve the general understanding of changing market demand.

The **private sector** needs to

- Understand the environmental and social concerns of government and local communities;
- Be able and willing to provide the expertise and access to finance to develop and operate tourism facilities and services;
- Assume collective responsibility for laying down the industry's standards, ethics, and fair practices;
- Contribute to preserving culture and heritage and protect the environment, taking the lead in educating travellers about the need for sustainable development;
- Involve local communities in tourism development and ensure that they enjoy their fair share of the benefits;
- Undertake training and manpower development for the industry to achieve excellence in the quality of services;
- Work with governments to ensure the safety and security of tourists;
- Contribute to improved research and the development of statistical databases; and
- Harness technology to improve the efficiency of tourism operations, marketing, and quality of service.

Critical success factors

Although there is clearly no single formula for public-private sector cooperation, several factors have been identified critical to its success. The most prominent among them are given below:

- A balanced structure within the partnership with clear roles and responsibilities for all partners
- Shared leadership between the public and private sector with shared well-defined goals, realistic expectations, and the identification of benefits for each partner
- A flexible approach on the part of all partners, combined with a willingness to understand each other's needs and to contribute to shared resources
- Understanding between all partners that tourism development must be sustainable: economically, socially, and environmentally
- A long-term commitment combining a strategic vision and plan with shorter-term goals and measurable initiatives
- Periodic evaluation of the efficacy of each partner's role
- Good communication between partners and with other stakeholders

Role of NTOs/STOs in SASEC countries

This section introduces the NTOs of Bangladesh, Bhutan, Nepal, and Sri Lanka. The Bangladesh Parjatan Corporation and the Department of Tourism in Bhutan are both government bodies, whereas the Nepal Tourism Board is a public-private partnership. Sri Lanka already established a 'tourism cluster' in which the Sri Lankan Tourist Board is one of the stakeholders. Most of the information in this section has been taken from the websites of the NTOs discussed.

Bangladesh Parjatan Corporation

The Bangladesh Parjatan Corporation is the national tourism organisation in Bangladesh. Its main tasks and functions are defined as follows:

- Promote and develop tourism
- Establish tourism infrastructures in Bangladesh
- Provide facilities to undertake measures and carry out all kinds of activities connected with tourism

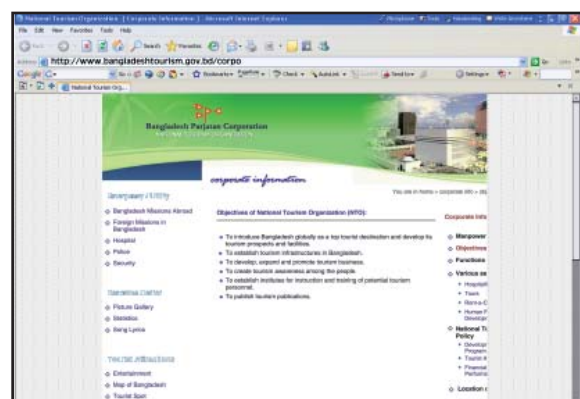

- Acquire, establish, construct, arrange, provide, and run hotels, restaurants, rest houses, picnic spots, camp sites, theatres, amusement parks, and facilities for water skiing and entertainment
- Establish institutes for the instruction and training of tourism personnel
- Produce tourism publications.

Box 12.1 shows an example of a successful public-private partnership in Bangladesh.

Box 12.1: Public-Private Partnerships in Bangladesh

Case Study: Foy's Lake

The Lake
 Foy's Lake is a man-made lake created during British colonial rule in the early 19th century. The purpose of the lake was to supply water to railway staff. The lake covers 337 acres, is surrounded by beautiful hills, and forms the blue water reservoir of the country. Rainwater from the hill is reserved. The depth of the reservoir is 30 to 40 feet. The lake was lying abandoned for many years, but its scenic beauty continued to attract people. The attraction turned itself into a tourism product. The lake is located in Chittagong, about 300km from Dhaka, and can be reached by road, rail, and air.

The transformation of the project into a successful sustainable tourism product
 In 2002, the government made a decision to tap the potential of the lake. It developed a plan to make the lake an international standard tourist centre without damaging the environment. The ownership of the lake was handed over to the NTO to create facilities.

The public-private partnership
 The NTO involved the private sector as per government policy. A tri-party agreement was signed between the railway, the NTO, and a private entrepreneur (Concord). The private sector has been involved in creating facilities on a BOT (build, operate, transfer) basis for the past 40 years.

Foy's lake is a good example of a successful public-private partnership.

Source: Bangladesh Parjatan Corporation 2006

Department of Tourism, Bhutan

Tourism, being a multidisciplinary sector, is often dependent on the initiatives of other sectors for its development. The Department of Tourism (DoT) in Bhutan was instrumental in the formation of the Association of Bhutanese Tour Operators (ABTO) as a bridge between the private sector and the government. A Tourism Development Committee has been established with representatives from



all relevant sectors to provide sound and comprehensive functional guidelines and approaches to tourism issues. The DoT strives to bring problems to the notice of the Tourism Development Committee to ensure that tourism development can take place in a properly co-ordinated manner with the active cooperation of all the agencies involved. A Tourism Development Fund was created in 1999 with contributions from tour operators of US \$10 for every tourist they bring in. The Tourism Development Committee acts as the sanctioning authority for the use of this fund for all approved plans and programmes.

The functions of the Department of Tourism include the following:

- **Tourism planning and policy:** Formulate, implement, and update a national tourism policy and strategy in consultation with relevant stakeholders;
- **Regulation and monitoring:** Develop and implement relevant tourism guidelines and regulatory measures for the sustainable use of natural and cultural resources and ensure compliance;
- **Facilitation and coordination:** Establish a safe, secure, and healthy environment for visitors; promote and facilitate private sector investment in the tourism industry; promote tourism as an important national priority; coordinate tourism-related efforts among all stakeholders in the industry; facilitate daily operational procedures; and facilitate and assist in improving visitor relations and experience;
- **Marketing and promotion:** Actively carry out and facilitate the marketing and promotion of the country as a tourism destination through tourism fairs, by exploring potential new markets, and promotional literature;
- **Development of tourism products and services:** Diversify and develop new tourism products to create balanced and sustainable tourism compatible with the environment and society; and
- **Human resource development:** Facilitate the manpower and skill requirements of the tourism sector through opportunities for training and advancement.

Nepal Tourism Board

The Nepal Tourism Board (NTB) is a national organisation established in 1998 by an Act of Parliament. It takes the form of a partnership between the Government of Nepal and the private sector tourism industry and aims to develop and market Nepal as an attractive tourism destination. The NTB provides a platform for the visionary leadership of Nepal's tourism sector by integrating the Government of Nepal's commitment with the dynamism of private-sector tourism industry.

The NTB started by promoting Nepal on the domestic and international market and is working toward repositioning the image of the country (see also Chapter 9, Box 9.4). It aims to regulate product development activities in the future. The Secretary of the Ministry of Culture, Tourism, and Civil Aviation chairs the Board which has 11 board members made up of four government representatives, six private sector representatives, and a chief executive officer.



From 1966, under the NTB Act, the NTB has been mandated by the Government of Nepal to charge a tourist service fee for the marketing and promotion of tourism to Nepal. This fee is two per cent of the total tourist expenditure. This tourist service fee was replaced at the beginning of 2005 by a new mechanism to facilitate the attraction of tourists or guests to Nepal. At present visitors are levied around US \$7 upon departure from Tribhuvan International Airport, Kathmandu.

The organisational set-up and future challenges of the NTB are presented in Box 12.2.

Box 12.2: Organisational Set-Up and Future Challenges for the NTB

The NTB's statutory responsibilities include

- To develop and introduce Nepal as an attractive tourism destination in the international market
- To promote the tourism industry in Nepal while working for the conservation of natural, environmental, and cultural resources
- To work toward increasing the gross domestic product and foreign exchange income by promoting tourism
- To work towards increasing employment opportunities in the tourism industry
- To develop Nepal as a secure, dependable, and attractive travel destination by establishing a positive image of Nepal among the international travel trade community
- To work towards providing quality services to tourists visiting Nepal
- To conduct research and implement the findings for an improved understanding of tourism and to improve tourism trends
- To promote and develop institutions for the promotion of the tourism industry

The main objectives of the NTB are

- To develop, expand, and promote tourism by conserving as well as promoting the natural and cultural heritage of the country
- To create employment opportunities in the tourism sector
- To assist in establishing and developing necessary institutions for the overall development of tourism in the country

Major functions of the NTB include

- Marketing and promotion of existing and new tourism products
- Diversification of tourism products and resource development
- Tourism research
- Human resource development by providing short-term training courses
- Organising local and international tourism events
- Standardisation

Future challenges include

- Lack of financial resources
- Political instability
- Lack of advanced infrastructure
- Lack of a distinct tourism identity
- Competing with world-class marketing organisations
- Increasing competition down to consumer level
- Changes in consumer behaviour (e.g., distribution systems, and technology)
- Economic conditions and policy settings in source markets
- Changes in aviation carrier capacity, technology, airports, air rights, and air accessibility
- Quality research and human resource development

Sri Lanka



In April 2000, with the assistance of The Competitiveness Programme funded by USAID, a tourism cluster was formed in Sri Lanka by key tourism industry associations in order to devise a unified, industry-wide strategy to enhance the competitiveness of the tourism industry. A broad range of industry stakeholders participated in the cluster's strategy work and initiative development, including the Sri Lanka Tourist Board, universities, academic experts, community groups, regional tourism associations, and several public sector agencies.

The key objective of the tourism cluster is to develop and implement a strategy for competitiveness designed to increase the average spending per tourist by repositioning Sri Lanka as a recognised destination for sustainable, differentiated products and services that command a premium price. The key components of this strategy are to improve the tourism product mix, upgrade and develop existing tourism assets, modernise key industry institutions, and reform the policy environment. In 2004, the tourism cluster registered as a non-profit company with the continued mandate to develop and implement initiatives for competitiveness. The cluster has a board of ten directors of whom three are appointed by the Tourist Hotels' Association of Sri Lanka and three are appointed by the Sri Lankan Association of Inbound Tour Operators. The joint council of these two associations appoints the chairman, and the other three directors are invited from other key players in the tourism industry. The key strategic initiatives of the tourism clusters are as follow:

- **Improve the tourism product mix:** This initiative calls for developing high-yield tourism products that appeal to independent, big-spending tourists. The products proposed include ecotourism and adventure tourism which will be developed by establishing associations, standards, and accreditation, and by undertaking demonstration projects.
- **Upgrade tourism assets:** This initiative supports the improvement of the product mix by adding value to and promoting unique Sri Lankan assets such as the Sigiriya rock fortress. It also calls for upgrading tourism on the southwest coast by transforming the Galle Fort into a major attraction, commensurate with its status as a United Nations Educational, Scientific and Cultural Organisation World Heritage Site.
- **Modernise tourism organisations and key institutions:** This initiative supports establishing a national, industry-led promotion and marketing organisation as a first step towards:
 - the formation of a private public tourism authority driven by the private sector;
 - setting up an Internet portal for the industry to stimulate destination marketing; and
 - addressing human resource needs through development of the industry's key education and training organisations.
- **Reform the policy environment:** Addressing policy and regulatory issues that benefit the industry's competitiveness. These could include civil aviation policy, reforms to improve tourism-related infrastructure, policies for taxation, tourism planning and regulation, land planning, and environmental protection.

The tourism cluster is currently involved in implementing several initiatives, including establishing a demonstration model for best practice ecotourism, setting standards for eco-lodges, and promoting and encouraging energy efficiency in the hotel sector in line with the overall strategy. The cluster is also in the process of restructuring its private-public partnership arrangements. Previously, the state-owned Sri Lankan Tourist Board operated with limited public funding and was responsible for promotion, regulation, planning, and standards. The plan for restructuring the industry proposes that these functions be shared between several organisations:

- **Tourism Development Council:** The Tourism Development Council will primarily be a public body with private sector participation, set up to manage the planning and regulatory functions of the Sri Lankan Tourist Board and the five regional councils for tourism development.
- **Tourism Marketing Bureau:** The Tourism Marketing Bureau is a body managed by the private sector set up as a company by guarantee; this has been approved by the Cabinet and will receive 80 per cent of the funds raised by the tourism industry tax. The Comparativeness Programme and the tourism cluster have long advocated for private sector control over tourism promotion.
- **Institute of Hospitality and Tourism Management:** This hotel school (receiving 10-15% of the tourism tax) will most likely be placed under private sector management in the medium term and the name changed to National Institute of Travel and Tourism, with a broader mandate and wider industry participation than heretofore.

Tax on the industry has been collected since 2003 and consists of one per cent of the revenue of all organisations registered with the Tourist Board and US \$5 on all airline tickets.

Roles of NTOs/STOs in a tourism cluster

Although there appears to be strong agreement among stakeholders on the philosophy behind public-private sector cooperation and partnership, it is clear that there are many different ways of developing a public-private partnership and putting it into practice. In other words, there is no single correct model or formula. Their structure and purpose depend on local circumstances such as the state of tourism development in the destination and the extent to which the private sector is economically capable and willing to assume part of the responsibility for tourism development.

In the previous paragraphs different examples were provided. In Bangladesh, the Bangladesh Parjatan Corporation takes an initiating role. In Bhutan the government recognises the role of the ABTO as a bridge between the private sector and the government. In Nepal, the NTB is a partnership between the private sector and the government, and in Sri Lanka a 'cluster' has been introduced.

Success ultimately depends on the commitment of all stakeholders in the tourism cluster to be competitive by translating their vision and strategy into action and results.

Balance between Public and Private – Competitiveness is Key

Competitiveness is the key to prosperity for tourism destinations through cooperation and partnership. Destinations that provide 'better value' at a minimum 'cost' or 'effort' generally have most success. More sophisticated forms of cooperation entail long-term partnerships between local tourism clusters, governments and other central authorities, and international organisations. For more information on opportunities for public-private cooperation in tourism cluster development, see Volume 2 (Tool 3).

Competitiveness is the capacity of a destination to compete successfully against its main rivals in the world, to generate above average levels of wealth, and to sustain this over time at the lowest social and environmental cost. To understand and share this view is a basic prerequisite for building an effective framework of cooperation in public-private sector tourism.

Most tourism clusters are diversified and operate in different sectors at the same time. This requires two levels of strategy: a sectoral strategy (competitive positioning) and a cluster strategy (the global plan for a diversified cluster). Tourism competition takes place between clusters that operate simultaneously in different sectors.

A sector is composed of clusters that compete for the same markets with similar tools. For instance, trekking areas in Sikkim and Uttarakhand in India, and Kanchenjunga and Langtang regions in Nepal, all compete in the market of medium-to-lower-priced trekking package tours, use the same distribution channels, similar technologies, and have similar competitive advantages.

But these sectors also tackle other markets like domestic and regional pilgrimages in Uttarakhand and Nepal, domestic sightseeing tours, and so forth. In each of these markets they face different rivals in different sectors.

The cluster strategy, on the other hand, determines the markets in which the cluster must operate and how to establish policies and guidelines geared to obtain the maximum economies of scale, synergies, and benefits for the whole cluster.

Chapter 13

Analysis and Assessment Instruments

This chapter covers

- The systems and instruments that are used to design institutional development and organisational strengthening interventions in sustainable mountain tourism
- Use of these instruments and systems in the different stages of the tourism project cycle or process of analysis

Introduction: Analysis Process and Use of Instruments in Tourism

Within NTOs and STOs there is a need for insight into the various types of instruments available and applicable to the field of project cycle facilitation and management that could assist NTOs and STOs in the formulation, management, and facilitation of sustainable mountain tourism development projects. These instruments could be particularly useful for the analysis of systems of local governance; assessment of the capacity of local government; and in the analysis of the institutional context and the local stakeholders.

This chapter introduces analysis and assessment systems (adapted from MDF 2000). It provides assistance to NTOs and STOs in selecting and applying instruments for future sustainable mountain tourism development projects: it deals with instruments and methods of analysis and assessment that are commonly used at two levels: i) the sectoral level and ii) the organisational level. In Volume 2 (Tools), each instrument is described in detail explaining what it is, when it is used, and how to apply it under three standard headings.

Most of the analysis and assessment tools or instruments introduced have their background in the generic development sector and, therefore, may require some more adaptation to make them applicable to sustainable mountain tourism.

Use of instruments in the tourism project cycle

The systems, tools, and instruments described in this chapter contribute to the collection of information about the institutional set-up of a proposed tourism intervention and provide information for use in the decision-making process (e.g., for the selection of a tourism sub-sector and stakeholders and to find the appropriate modality for collaboration and partnerships); analysing the strengths, weaknesses, opportunities, and threats (SWOT; see Volume 2, Tool 15) of a potential key strategic partner organisation; and deciding on modalities for building and improving their organisational and institutional capacities. Most of the tools or instruments discussed in this chapter are used in the initial stage of a project cycle (during analysis and assessment) leading to strategic choices on which part of the tourism sector to involve, with which stakeholders and key partners to collaborate, and their responsibilities as part of the tourism planning or designing a tourism intervention.

Some major uses of the instruments that are found in Volume 2 are depicted in Figure 13.1, which gives a general model of a project cycle. However, this does not mean that these instruments cannot be used in other stages of the project cycle. Moreover, this is only one of the representations of the project cycle. Other representations may be relevant as well, with similarities in the positioning of the instruments.

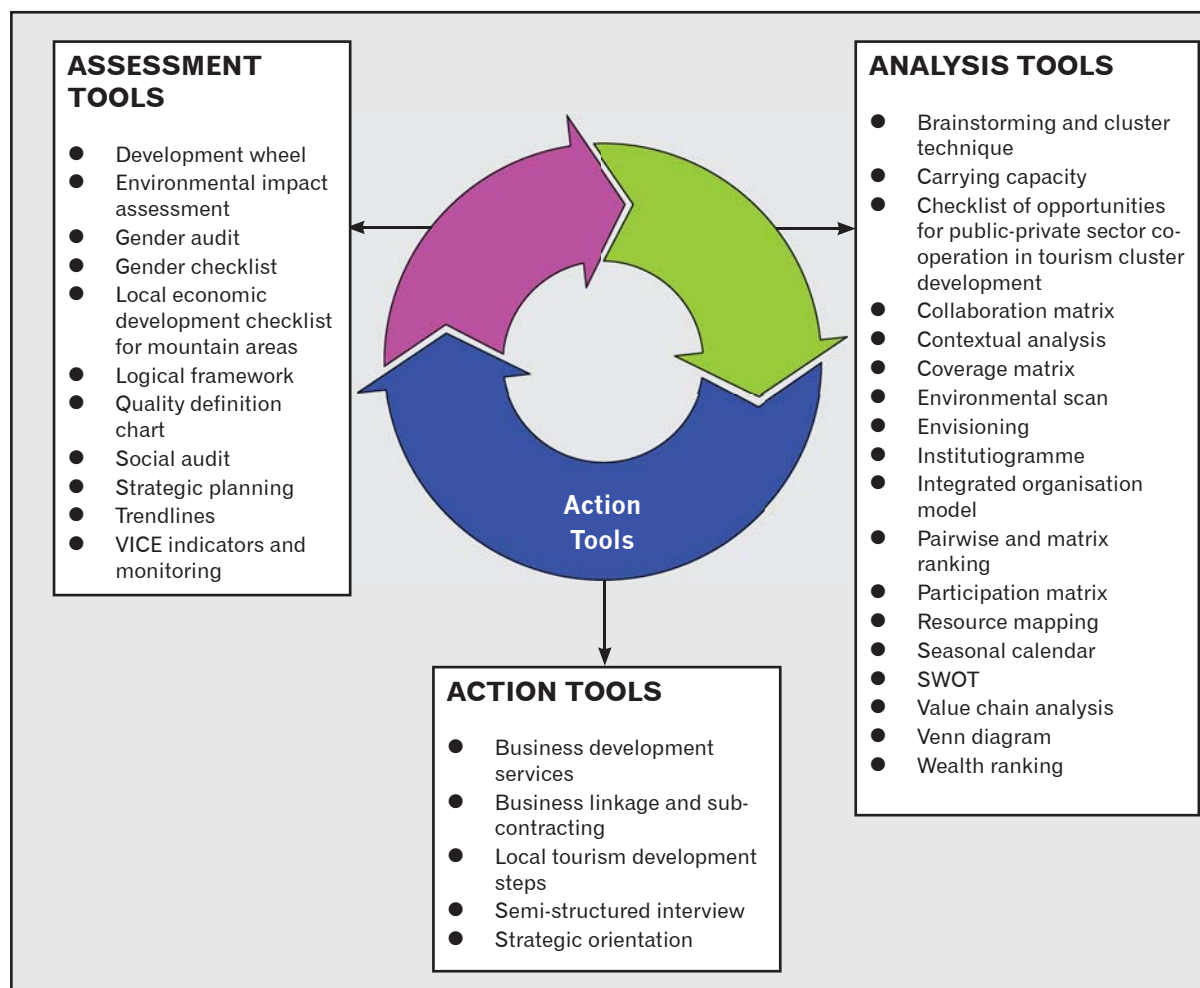

Figure 13.1: Triple-A tools in the tourism project cycle

Use of instruments in the analysis process

Various instruments may have different uses in different stages of the tourism project cycle. Analysis takes place in all stages of the project cycle. In many cases, analysis does not lead to new tourism project documents, but rather to the improvement of tourism strategies. It is, therefore, also relevant to look at the different phases of an analysis process and to look at the use of different instruments in that process.

It is important to realise that analysis may be carried out by tourism project managers or their staff or by teams consisting of different stakeholders with different backgrounds and expertise. Often, participatory analysis is being followed in which stakeholders participate in analysing the situation and draw conclusions from the information available. These participatory analyses often lead to more realistic conclusions that are more easily implementable.

The use of instruments can add much to the insight obtained in existing situations, to the clarity of problem identification, and the quality of the participatory analysis.

The following major phases in the analysis process can be distinguished:

1. Formulating a basic question
2. Fact-finding, analysis, and assessment
3. Formulating strategies
4. Design and implementation

Formulating a basic question

The process of analysis starts with the question of the problem owner. The problem owner could be the same as the client (the one financing the assignment), but it could also be a different person. The client system can be defined as all the persons or groups (stakeholders) that may be involved in the change process.

Without an initial question, it is difficult to make an adequate analysis. The initial question may not yet be formulated in very operational terms, and it is often necessary to assist the problem owner in reformulating and specifying the initial question into a 'basic question' that will guide the process of analysis. A good basic question ensures that the analysis will not be too broad (too many actors and aspects) or too limited (insufficient actors and aspects) to come to a relevant and meaningful assessment. Examples of basic questions include the following:

- How does the local government change from an executing to an enabling agency?
- What are the current and desired functions of the local government and what kind of capacity development is necessary to carry out the desired functions?
- What should be done to enable the Department of Agriculture to carry out effective extension services for farmers?
- How can the NGO involve its target group to increase the effectiveness of its health services?

During the process of formulating a basic question the use of instruments may assist in clarifying the following:

- The area that is subject to analysis
- The problem, its background, and its context
- The client system: the stakeholders and their expectations, including the problem owner (the person to assist) and the client (the person to report to)
- The expectations of the stakeholders towards the tourism advisor or team, what they are expected to do, and what not to do
- The support and the level of involvement of the different stakeholders (depending on the situation this could range from the tourism advisor or team doing almost everything to a high level of participation and contribution by stakeholders in all steps)

In general these expectations are written down in the terms of reference (ToR).

Fact-finding, analysis, and assessment

The second major phase of the analysis includes fact-finding (data collection), analysis (finding key-problems, relations, and explanations), and assessment (making a judgment). Most of the instruments can be used for each of these activities. Depending on the situation and the data collected, however, there may be differences in the use.

In choosing an instrument one has to realise that each instrument has its own limits, i.e., focuses on certain aspects of reality, while other aspects are left out. It is, therefore, very important to be aware of these limitations and constraints. In the most complex situations the use of different complementary instruments can be useful.

In the **fact-finding** stage, instruments could help with the following:

- Understanding the different aspects of the problem situation.
- Determining the stakeholders in relation to different aspects.
- Choosing the right data-collection techniques including questionnaires, interviews, observations and field trips, documents and files, workshops, or discussions.
- Choosing the focus of the data collection.
- Selecting items and formulating questions for the different items ensuring that all relevant aspects are covered in a cost-effective way.

Instruments used in the **analysis** stage may be similar to those of the fact-finding stage, but there may be differences as well. In the analysis phase, instruments are used to do the following:

- Organise the data collected
- Distinguish the presentation of facts (observations) from their respective interpretations (conclusions)
- Visualise the information and facilitate participatory discussions
- Create insight into the relations between problems identified and assess the relevance of observations
- Identify core problems and opportunities
- Draw conclusions for strategies and future tourism actions

In order to judge the performance of an organisation or the relevance or importance of problems, clear criteria and indicators are necessary. Instruments often distinguish between various aspects of a problem field. In this sense they can help to develop **assessment** criteria and related indicators. However, what acceptable values are, must come from other sources. Some of these sources are given in the list below:

- Objectives, targets, and norms specified or derived from organisational policies
- Facts and figures drawn from the tourism sector
- Bench marking, i.e., comparison with other similar organisations
- Government or public rules and regulations
- The professional assessment of an experienced tourism consultant
- Facts and figures based on past experiences in the organisation (historical norms)
- Facts and figures drawn from professional tourism literature

Strategy formulation

Based on the analysis and assessment, tourism strategies can be formulated, often through a creative process in which alternatives and their consequences are discussed by the various stakeholders. In this process instruments can be used to do the following:

- Involve stakeholders
- Define the various options for addressing problems and opportunities
- Weigh the different options
- Create consensus on the best option(s) to choose

Design and implementation

After a tourism strategy is formulated and agreed upon by major stakeholders, the details have to be worked out and consequences analysed, including how the strategy will affect the various stakeholders. In this stage instruments can be of use to carry out the following tasks.

- Analyse the consequences for the various stakeholders
- Design new systems, procedures, structures, and approaches
- Plan concrete tourism activities

Overview of the analysis process and use of methods and tools

There are four main levels of institutional development and organisational strengthening:

1. **Diagnosing and learning:** Action-oriented learning on tourism and development problems of NTOs and STOs.
2. **Organisational development:** Activities to build the capacity of NTOs and STOs to become more effective and learn to adjust to their environment.
3. **Partnership building:** Building the capacity of (groups of) organisations to interact, collaborate, and negotiate to plan, develop, implement, and manage sustainable mountain tourism.
4. **Institutional change:** Support NTOs and STOs in influencing tourism policies and institutional change in order to improve the enabling environment.

Based on these levels, a link can be made between sustainable mountain tourism practice and respective methods and tools in institutional development and organisational strengthening (IDOS) (see Box 13.1).

Analysis and Assessment Systems in Tourism

In this section, analysis and assessment systems are discussed. A distinction is made between analysis and assessment instruments like the institutiogramme (see Volume 2, Tool 9), and analysis and assessment systems, like rapid (or relaxed) appraisal of agricultural knowledge systems (RAAKS) and IDOS, which consist of a sequence of instruments. These systems are introduced in this section and the individual instruments are explained in Volume 2.

Rapid Appraisal of Agricultural Knowledge Systems

What is it?

RAAKS is an action-oriented research methodology that can help diverse stakeholders to work and learn together, enhance communication and information exchange, and to plan for action to support innovation. RAAKS has been designed and tested to help stakeholders gain a better understanding of their performance as innovators. Men or women villagers, researchers, policy makers, extension workers, consumers, producers of inputs or services, and industrialists and/or traders guided by a team of specialists can all be involved in a RAAKS study. Central elements of RAAKS are teamwork, the focused collection of information, qualitative analysis, and strategic decision making. The RAAKS methodology has been adapted to tourism-related analysis and planning. Pramod Tandukar's thesis (1999, unpublished), developed for SNV Nepal and Wageningen University, provides several examples from tourism development in Nepal.

What can be done with it?

RAAKS is useful in identifying opportunities for improving tourism knowledge and information systems and creating awareness among relevant actors of opportunities and constraints that affect their performance as innovators. This approach also supports the identification of actors and potential actors able to address constraints and opportunities and encourages their commitment to change.

Core questions are as follows:

- Who are the major stakeholders in the tourism sector?
- What are the major constraints to innovation?
- What can be done to address these constraints?

**Box 13.1: Linking Sustainable Mountain Tourism Practice
with IDOS Tools and Methods**

Level of Analysis/ Assessment Intervention	Method/Tool
1. Diagnosing and Learning	
Capacity assessment/ organisational assessment of NTOs/STOs to identify their capacities and capacity constraints	<ul style="list-style-type: none"> ● Capacity assessment method ● IDOS ● RAAKS (rapid appraisal of agricultural knowledge system) ● APPA (see Chapter 6) ● IOM model together with interviews (see Volume 2, Tool 10) ● SWOT (see Volume 2, Tool 15)
Mountain tourism and market research	<ul style="list-style-type: none"> ● Market research ● Departing visitor research
Mountain tourism feasibility studies	<ul style="list-style-type: none"> ● Social analysis: social and environmental resource mapping, walks, surveys, and others. ● Mountain tourism feasibility checklist
Knowledge development	<ul style="list-style-type: none"> ● Development of specific tools or support on knowledge areas defined by NTOs and STOs
Coaching and training	<ul style="list-style-type: none"> ● Regular coaching chapters with individuals ● Training on pro-poor tourism principles, hospitality, on-the-job training, and specific training requested by NTOs and STOs
Documenting and sharing best practices in sustainable mountain tourism	<ul style="list-style-type: none"> ● Case studies on sustainable rural tourism and pro-poor principles in tourism ● Sharing experiences and best practices via the sustainable tourism network and group
2. Organisational Strengthening	
Mountain tourism policy and strategy development	<ul style="list-style-type: none"> ● Visioning exercises ● APPA ● RAAKS ● Advice to develop national strategies (for example, the Lao National Ecotourism Strategy and Action Plan)
Mainstream pro-poor principles in tourism development and management	<ul style="list-style-type: none"> ● Client-specific awareness raising, training, and support to technical resource development ● Facilitating links with international networks and specialist sustainable mountain tourism markets
Mainstreaming gender and social inclusion in sustainable mountain tourism	<ul style="list-style-type: none"> ● Remind NTOs and STOs of gender and social inclusion issues in daily advice on different assignments ● Presentation and discussion of gender and social inclusion issues during sustainable tourism network meetings ● Gender assessment implementation of gender action plans in national tourism organisations (Chapter 8) ● Social inclusion strategy (Chapter 8)
Mountain tourism information systems' development	<ul style="list-style-type: none"> ● Develop an improved system for gathering tourism statistics ● Training on how to use the system ● Set up tourism information centres
Mountain tourism education and awareness raising	<ul style="list-style-type: none"> ● Support for tourism curriculum development for different faculties of different universities ● Presentations and discussions on topics related to sustainable mountain tourism

Box 13.1: (cont...)

Mountain tourism products and quality standards' development and management	<ul style="list-style-type: none"> ● Quality definition chart to define the quality of tourism products and services (see also Volume 2, Tool 30) ● Tourism and hospitality training (based on the output of the quality definition chart) ● Facilitate the implementation of product development ● Facilitate collaboration with the private sector
Mountain tourism business planning development	<ul style="list-style-type: none"> ● Business planning and skills' training for tourism-related micro enterprises ● Support for small and micro tourism products and service providers' associations and groups ● Facilitate links between local, sustainable mountain tourism producers and service providers and markets (national and international) ● Mountain tourism enterprise development and market linkages' approach (Chapter 9)
Strengthening organisational structure and systems	<ul style="list-style-type: none"> ● Capacity development plan ● Among others the following methods are used: process mapping (work processes); process facilitation (ongoing); institutiogramme (Vol. 2 Tool 9; IOM (Vol. 2 Tool 10); SWOT (Vol. 2 Tool 15); envisioning (Vol. 2 Tool 8); coaching; team building; participation matrix (Vol. 2, Tool 12)
3. Partnerships/Relationships with Direct Environment	
Planning for sustainable mountain tourism	<ul style="list-style-type: none"> ● APPA ● RAAKS
Conservation of natural resource base and poverty reduction in protected areas	<ul style="list-style-type: none"> ● Design ecotourism management systems for implementation in all national and provincial protected areas ● Develop ecotourism strategies and management plans for target or model protected areas
Mountain tourism promotion and facilitation of market linkages	<ul style="list-style-type: none"> ● Mountain tourism enterprise development and market linkages' approach (Chapter 9)
Develop sustainable tourism networks	<ul style="list-style-type: none"> ● Facilitate the set-up and management of these networks ● Raising awareness on pro-poor and sustainable mountain tourism practices and approaches ● Strategic planning (see also Volume 2, Tool 32) ● Set up of an organisational structure and systems
4. Institutional Change	
Institutional linkages and associations within sectors	<ul style="list-style-type: none"> ● Actogramme or institutiogramme
Mountain tourism legislation development	<ul style="list-style-type: none"> ● Process facilitation
Sustainable management of natural resources	<ul style="list-style-type: none"> ● Influencing policy ● Support with specific curricula development ● Awareness raising

The RAAKS method could be complemented by an adequate organisational analysis of actors involved in the use of tourism project planning techniques.

How can it be used?

The RAAKS methodology consists of three major phases, each with a number of ‘windows’ (aspects for analysis) and related tools that can be followed. The RAAKS methodology is carried out by a team of trained experts and involves stakeholders in various workshop exercises. The extent to which analysis is being carried out depends on the priorities of the situation. Box 13.2 gives an overview of the main tools that can be used in each phase.

Requirements and limitations

The RAAKS method requires a team of experts. The field work will depend on the situation and the field of analysis, but will require at least two to three weeks. Various workshops are required for participants. It requires a willingness and ability on behalf of the stakeholders to contribute and to address the constraints identified. Too easy or too high expectations may be generated, which may be counter productive in later stages of development. Emphasis is on communication and information, not so much on other elements of organisational performance.

Box 13.2: RAAKS Model

Phase A: Defining the relevant system and its problems		
Window	Tool Name	Description
A1 Defining or re-defining the objective of the diagnosis	Problem definition exercise	Questioning
A2 Identifying relevant actors	Actor identification exercise	List of actors and involvement
A3 Tracing diversity in mission statements	Actor objective sheet	List actors plus mission
A4 Environmental diagnosis	Environmental limits’ checklist	Checklist: environmental complexity, technology, external pressure, resource base, and tourism support services
A5 Clarifying the problem situation	Prime mover septagram Approximation exercise I: leadership and coordination Approximation exercise II: problems and diversities	Picture of main actors and the extent to which they influence the tourism system Picture of actors and relations Questions for synthesis of Phase A findings
Phase B: Analysis of constraints and opportunities		
B1 Impact analysis	Impact analysis sheet	Matrix needs of client groups versus knowledge offered
B2 Actor analysis	Actor analysis checklist	List of actors, their primary activities, position in tourism knowledge system, and their impact

Box 13.2: (cont...)

B3 Tourism knowledge network analysis	Info-source-use exercise	Matrix on sources of tourism information and their various uses
	Communication network sheet	
	Source intermediary user sheet	Circles showing closeness and/or importance List showing per knowledge type how it is offered by the source and transformed by the intermediary for which final users
B4 Integration analysis	Linkage matrix	Matrix of actors showing linkages
	Linkage mechanism checklist	Checklist with questions on the type of linkage
B5 Task analysis	Task analysis sheet	Matrix of actors and tourism activities
B6 Coordination analysis	Basic configurations	Combining driving force (tourism policy, user, technology, industry, and donor) with Mintzberg coordination mechanism (see A5)
	Prime mover septagram	
B7 Communication analysis	Communication analysis exercise	Questions on differences between actors: social, cultural, knowledge, perceptions, and so on
	Window reporting sheet	Overview of contributions of windows used
	Understanding the social organisation of innovation	Synthesis of results phase A and B

Phase C: Articulating policy and strategy/planning for action

Window	Tool Name	Description
C1 Tourism knowledge management analysis	Tourism knowledge management analysis exercise	Selection of actors and potential tourism interventions (using checklist)
C2 Actor potential analysis	Actor potential checklist	Assessment of the actors in relation to the potential tourism interventions (using checklist)
C3 Strategic commitments to a tourism action plan	Defining possible actions: moving towards improvement	Synthesis of results from phases A, B, and C
	Strategic commitments: action planning	Constraints and opportunities (using checklist) Defining which objectives, activities, and who is responsible (checklist)

Institutional development and organisational strengthening (IDOS)

What is it?

The IDOS analysis framework consists of a flexible set of instruments to be used in analysing the institutional environment in the analysis of the (internal) organisation, and in synthesising these analyses into a comprehensive plan to make the organisation or network more effective in carrying out tourism development activities. With regard to sustainable mountain tourism interventions, this framework can be useful for analysing the tourism policy framework, the key actors involved in tourism, the effectiveness of the institutional arrangements between and among these actors, and for suggesting measures to improve the effectiveness of the sustainable mountain tourism sector in a particular context. The IDOS framework is shown schematically in Figure 13.2.

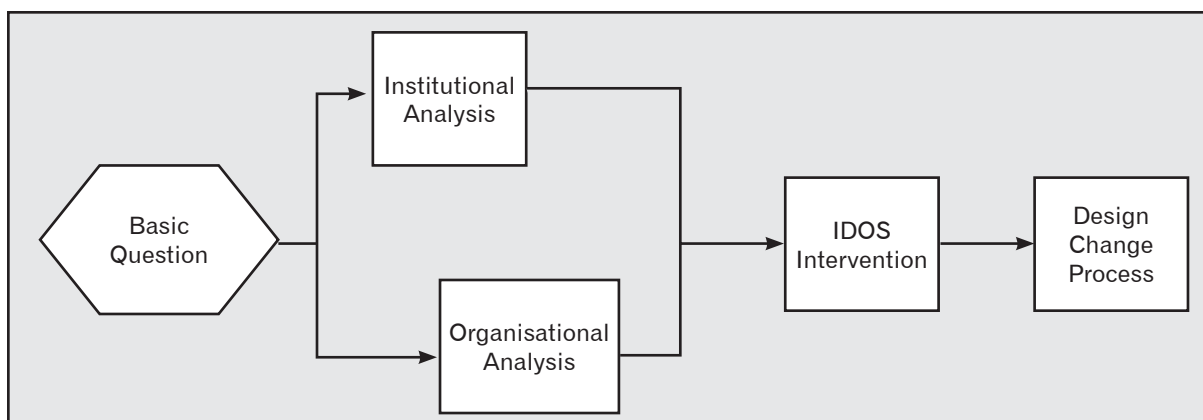

Figure 13.2: IDOS basic framework

The IDOS analysis can take place at various levels: at the level of the sustainable mountain tourism project, the tourism department or ministry level, the level of the national, state or local tourism organisation, at the tourism sector level, or at the tourism development programme level. The scope may be broad or limited, but requires the thorough participation of major stakeholders involved in sustainable mountain tourism.

What can be done with it?

The IDOS analysis assists in designing a tourism intervention strategy (what should be changed or adapted) and in the change process (how should it be changed) at the level of the institutional setting and at the level of the organisations involved in the sustainable mountain tourism sector to improve the effectiveness, efficiency, and sustainability of the sector as a whole.

Core questions are as follows:

- How to position a tourism development project?
- How to coordinate and cooperate between organisations involved in tourism activities?
- How to develop a network of organisations involved in tourism?
- What should be done to improve performance in tourism development?
- How to develop or strengthen NTOs and STOs in terms of effectiveness, efficiency, and sustainability?

More specific and detailed analysis may have to be carried out depending on the tourism strategies chosen or formulated. The instruments described below can be useful in carrying out such specific analyses.

How can it be used?

Steps in institutional development and organisational strengthening (IDOS)

- **Step 1: Formulating a basic question** – The formulation of a question that clearly indicates the problem to be addressed and/or resolved
- **Step 2: Institutional analysis** – The design of an IDOS intervention has its starting point in the description and analysis of the environment (context) of sustainable mountain tourism in a particular context. This includes the analysis of actors involved (target groups, NTOs and STOs, other organisations including NGOs, government, private sector, financiers, and so forth) and the influencing factors (political, economic, sociocultural, technological, physical, market, and so forth). The institutional analysis provides insight into the opportunities and threats within and outside the tourism sector.

Possible instruments: *institutiogramme* (Tool 9), *coverage matrix* (Tool 6), *collaboration matrix* (Tool 4), and *environmental scan* (Tool 7) (see Volume 2).

- **Step 3: Organisational analysis** – Organisational analysis provides an overview of the strengths and weaknesses of the project or organisation, whatever the focus of the assessment. A general assessment provides a direction for a more detailed analysis of systems and work processes, structure, management styles, staff motivation, and organisational culture within an NTO or STO.

Possible instruments: *integrated organisation model (IOM)* and a *checklist* (see Volume 2, Tool 10)

- **Step 4: Designing IDOS intervention** – The analysis phase leads to ideas on improving the NTO and interlinkages with other stakeholders for an effective, efficient, and sustainable mountain tourism sector. These ideas are translated into a concrete IDOS intervention plan that aims to improve the sector through strengthening institutional and organisational relationships and collaborations.

Possible instruments: *strategic orientation*, *logical framework* (see Volume 2, Tools 23 and 29)

- **Step 5: Designing change process** – An intervention plan for improving institutional relationships and organisational performance requires certain levels of change in policies, practices, and institutional or organisational norms and behaviour. A well-designed intervention plan should identify and foresee how different stakeholders will be affected by the change and where resistance might be expected. It should identify how different stakeholders should participate and how responsibilities should be divided among the actors involved for facilitation of the change process and related activities.

Possible instrument: *participation matrix* (see Volume 2, Tool 12)

Requirements and limitations

IDOS does not give a pre-determined sequence of steps to follow in going through the process. This implies that facilitators should be well aware of the use and limitations of different instruments so that they can be applied at relevant stages of the process with consideration of the need to generate and/or look into specific aspects of the institutional setting and/or within an organisation. The facilitators should always be well aware of sensitivities that may hamper the collection of information and discussions, and should be creative in choosing the right methods and instruments for facilitation of the process.

IDOS requires the participation of stakeholders to be able to make tourism interventions more acceptable and supported. An optimal participation can only be assured when the purpose and expected outcome(s) of the process are commonly understood by all stakeholders involved.

An IDOS process has to be carefully designed, based on the problem field at hand and the aspirations of the various stakeholders. It may consist of one or more well-prepared tourism analyses and strategic orientation workshops, coupled with teamwork to develop the ideas into a tourism intervention plan.

Instruments for Analysis and Assessment in Tourism

In the Box below (13.3), an overview is presented of the instruments presented in Volume 2 and their use in the analysis and assessment process in sustainable mountain tourism.

Box 13.3: Selected Instruments for Analysis and Assessment

	Formulating Basic Questions	Fact-finding Analysis and Assessment	Strategy Formulation	Planning and Design
1. Governance system				
1.1 Institutiogramme (see Volume 2, Tool 9)	+	X		+
1.2 Participation matrix (see Volume 2, Tool 12)		X		X
2. Sector analysis				
2.1 Checklist to diagnose local economic development (see Volume 2, Tool 28)	X	X		
2.2 Steps to develop the local economy		X	+	
2.3 Coverage matrix (see Volume 2, Tool 6)		X		X
2.4 Collaboration matrix (see Volume 2, Tool 4)		X		
2.5 Environmental scan (see Volume 2, Tool 7)		X		
2.6 Envisioning (see Volume 2, Tool 8)			X	
3. Organisation analysis				
3.1 Integrated organisation model (see Volume 2, Tool 10)	X	X		
3.2 Quality definition chart (see Volume 2, Tool 30)	+	X		X
3.3 SWOT/strategic orientation (see Volume 2, Tool 15 and 23)			X	

Notes: X = major use; + = can also be used for this step in the analysis

References

References

- 3 Sisters Adventure Trekking (2007) <http://www.3sistersadventure.com/>. Date of access: 13 March 2007
- Ashley, C.; Boyd, C.; Goodwin, H. (2000) *Pro-Poor Tourism: Putting Poverty at the Heart of the Tourism Agenda*, Natural Resource Perspectives 51, March 2000. London: Overseas Development Institute. See also: <http://www.haroldgoodwin.info/resources/51.pdf>.
- Ashley, C.; Roe, D.; Goodwin, H. (2001) *Pro-Poor Tourism Strategies: Making Tourism Work For The Poor A Review of Experience*, Pro-Poor Tourism Report No. 1. London: Overseas Development Institute. See also: http://www.haroldgoodwin.info/resources/ppt_report.pdf
- Australian Government (2004) *Planning a Sustainable Future for Tourism, Heritage and the Environment. A Tool to Use When Managing and Developing Regions, Places and Tourism Products*. <http://www.deh.gov.au/heritage/publications/sustainable-tourism/index.html>. Canberra: Department of the Environment and Heritage
- Bangladesh Parjatan Corporation (BPC) (2006) *Foy's Lake: Case Study of a Successful STD Project in Bangladesh*. Country Presentation at Training on Project Facilitation and Management in Sustainable Tourism Development, ICIMOD, Kathmandu, 12 June 2006
- Banskota K.; Sharma, B. (1998) *Mountain Tourism for Local Community Development: Training Manual for Programme Designers and Implementers*. Kathmandu: ICIMOD
- Banskota, K.; Sharma, B.; Neupane, I.; Gyawali, P. (1995) *Evaluation of the Partnership for Quality Tourism Project for the United Nations Programme*. Kathmandu: Centre for Resource and Environmental Studies (CREST)
- Brundtland, G. (ed) (1987) *Our Common Future*, The World Commission on Environment and Development. Oxford: Oxford University Press
- Buysrogge, W. (2006) *Multistakeholder Approaches in the Pro-poor Sustainable Tourism Sector in Three SNV Asia Countries (Lao PDR, Nepal, Vietnam)*, unpublished document, UNWTO/SNV Asia
- Cendant (2005) *The World of Travel in 2020: An Insight into the Drivers That Will Change End-traveller Behaviour and Shape the Future of the Travel Industry*. London: The Future Foundation/Cendant Travel Distribution Services. Autumn 2005. See also: www.futurefoundation.net/publications
- Cooper, C.F.; Wanhill, S. (1993) *Tourism: Principles and Practice*. London: Pitman Publishing
- CREST (1995) *Mountain Tourism in Nepal*. Discussion Paper, Series No. MEI 95/7. Kathmandu: ICIMOD
- De Lacy, T.; Battig, M.; Moore, S.; Noakes, S. (2002) *Public Private Partnerships for Sustainable Tourism: Delivering a Sustainability Strategy for Tourism Destinations*, CRC for Sustainable Tourism. Singapore: APEC
- Department of Tourism (DoT) (2006) *Sustainable Community Tourism Development Project: Project Overview*. Country Presentation at Training on Project Facilitation and Management in Sustainable Tourism Development, ICIMOD, Kathmandu, 12 June 2006
- DFID (2005) *Spreading the Net Wider: How to Reduce Poverty by Tackling Social Exclusion*. London: Department for International Development
- Drumm, A.; Moore, A.; Soles, A.; Patterson, C.; Terborgh, J.E. (2004) *Ecotourism Development. A Manual for Conservation Planners and Managers, Vol. II: The Business of Ecotourism Development and Management*. Arlington, Virginia: The Nature Conservancy
- East, P.; Luger, K.; Inmann, K. (eds) (1998) *Sustainability in Mountain Tourism: Perspectives for the Himalayan Countries*. Innsbruck-Vienna: Book Faith India and STUDIEN Verlag Austria

- FAO (2005) *Mountain Tourism: Making It Work for the Poor*. Rome: PAIA-MTNS/FAO
- Gurung, H. (1998) 'Sustainability and Development in Mountain Tourism'. In East, P.; Luger K.; Inmann, I. (eds) *Sustainability in Mountain Tourism: Perspectives for the Himalayan Countries*. Innsbruck-Vienna: Book Faith India and STUDIEN Verlag Austria
- Himachal Tourism (2006) *Presentation on Himachal Tourism*, Country Presentation at Training on Project Facilitation and Management in Sustainable Tourism Development, ICIMOD, Kathmandu, 12 June 2006
- IUCN (1980) *World Conservation Strategy*. Gland: IUCN
- Kayastha, Y. (2006) *Participatory Planning and Organisation Tools Used in Tourism: A Case Study of TRPAP*. Paper presented at Training on Project Facilitation and Management in Sustainable Tourism Development, ICIMOD, Kathmandu, 14 June 2006
- Kruk, E.; Banskota, K. (2007) *Mountain Tourism in Nepal: From Impacts to Sustainability*, internal document. See also <http://www.mtnforum.org/oldocs/679.pdf>
- Kruk, E.; Banskota, K. (in preparation) 'Pro-Poor Mountain Tourism in the Himalayas: Policies, Practices and Lessons Learned' (provisional title)
- Lama, W.B. (2000) 'Community Based Tourism for Conservation and Women's Development.' In Godde, P.M.; Price, M.F.; Zimmermann, F.M. (eds) *Tourism and Development in Mountain Regions*, pp 221-239. Oxford: CABI Publishing
- Lingen, A. (2003) 'Gender Assessment Studies – A Manual for Gender Consultants'. Cited in Shrestha, S.; Walinga, M., *Ecotourism: Planning and Management*. Pokhara: the Institute of Forestry
- Management for Development Foundation (2000) *Institutional Sector and Organisational Analysis*, Training Manual. BK Ede (The Netherlands): MDF
- McKercher, R. (2003) *Sustainable Tourism Development – Guiding Principles for Planning and Management*. Paper presented at the National Seminar on Sustainable Tourism Development, Bishkek, Kyrgyzstan, November 5-9, 2003
- Miller, G.; Twining-Ward, L. (2005) *Monitoring for a Sustainable Tourism Transition: The Challenge of Developing and Using Indicators*. Wallingford (UK): CABI Publishing
- Ministry of Hotels and Tourism (2006) *Mountain Tourism in Myanmar*. Country Presentation at Training on Project Facilitation and Management in Sustainable Tourism Development, ICIMOD, Kathmandu, 12 June 2006
- McIntyre, G.; Hetherington, A.; Inskeep, E. (1993) *Sustainable Tourism Development: Guide for Local Planners*. Madrid: United Nations World Tourism Organisation
- Nepal, S.K. (2003) *Tourism and the Environment: Perspectives from the Nepal Himalaya*. Lalitpur and Innsbruck: Himal Books and STUDIEN Verlag
- NTB (2006) 'Presentation to International Participants of Project Management Training'. Presentation at Training on Project Facilitation and Management in Sustainable Tourism Development, ICIMOD, Kathmandu, 14 June 2006
- NTNC (2006) *Tourism Planning and Management in Annapurna Conservation Area*. Paper presented at the Training on Project Facilitation and Management in Sustainable Tourism Development, ICIMOD, Kathmandu, 13 June 2006
- OECD (2006) *Glossary of Key Terms in Evaluation and Results-based Management*. <http://www.oecd.org/dataoecd/29/21/2754804.pdf>. Date of access: December 2006
- Örtengren, K. (2004) *A Summary of the Theory behind the LFA Method-The Logical Framework Approach*. See also <http://www.sida.se/publications>. Stockholm: Sida
- Pretty, J.N.; Gujit, I.; Scoones, I.; Thompson, J. (1995) *Participatory Learning and Action: A Trainer's Guide*. London: International Institute for Environment and Development

- Roe, D.; Urquhart, P. (2001) *Pro-Poor Tourism: Harnessing the World's Largest Industry for the World's Poor*. London: IIED
- Sharma, P. (ed) (2000a) *Tourism as Development: Case Studies from the Himalaya*. Innsbruck: Himal Books and STUDIEN Verlag
- Sharma, P. (ed) (2000b) 'Upper Mustang: Linking High-Value Tourism with Local Development.' In *Tourism as Development: Case Studies from the Himalaya*, pp 81-120. Innsbruck-Wien-Munchen: Himal Books and STUDIENVerlag
- Shah, K. (2000). *Tourism, The Poor and Other Stakeholders: Asian Experience*, Trade in Tourism Paper, ODI Fair. London: Overseas Development Institute
- Shrestha, S.; Walinga, M. (2003) *Ecotourism: Planning and Management*. Pokhara: the Institute of Forestry
- SNV (2002) *SNV's Advisory Practice, Emerging Lines*. The Hague: SNV Netherlands Development Organisation
- SNV (2003a) *Reference Guide on Business Development Services*. The Hague: SNV Netherlands Development Organisation
- SNV (2003b) 'SNV Nepal and Sustainable Tourism Development. Background paper.' In (SNV/Netherlands Development Organisation), *Reference Guide on Sustainable Tourism*, update September 2003. The Hague: SNV, Shared Service Unit/Knowledge Support
- SNV Asia (forthcoming) *A Toolkit for Monitoring and Managing Community-Based Tourism*. Hanoi (Vietnam): SNV Asia Pro-Poor Sustainable Tourism, and STCRC
- SNV Nepal (2004) *Developing Sustainable Communities, A Toolkit for Development Practitioners*. Kathmandu: ICIMOD
- Tandukar, P. (1999) *RAAKS for Sustainable Tourism Development*, MSc Thesis. Wageningen: Wageningen Agriculture University
- Tibet Tourism Bureau (2006) *A Survey of Tibet Tourism*, unpublished report. Lhasa: Tibet Tourism Bureau
- Touche Ross Management Consultants (1990) *Nepal Tourism Development Programme*, A Report for the Asian Development Bank and the Ministry of Tourism, Kathmandu. Kathmandu: ADB/MoCTA
- TRPAP (2006) *Case Study TRPAP: APPA Framework in Practice*. Presentation at Training on Project Facilitation and Management in Sustainable Tourism Development, ICIMOD, Kathmandu, 14 June 2006
- TMI (2000) *Community-Based Tourism for Conservation and Development: A Resource Kit*. Virginia, Spruce Knob: The Mountain Institute
- TMI (2007) *Integrating Improved Livelihoods and Conservation Through Tourism*. Presentation at Training on Sustainable Tourism Market Linkages, ICIMOD, Nepal, 18 January 2007
- UNDP (2006) *Handbook on Monitoring and Evaluating for UNDP*. http://www.undp.org/undpweb/eo/evalnet/doc/yellowbook/documents/part_1.pdf. Date of access: December 2006. New York: UNDP
- UNEP/UNWTO (2005) *Making Tourism More Sustainable. A Guide for Policy Makers*. Nairobi: United Nations Environment Programme (UNEP); Madrid: United Nations World Tourism Organization
- UNWTO (1997) *Towards New Forms of Public-Private Sector Partnership*. Madrid: United Nations World Tourism Organisation
- UNWTO (1998) *Guide for Local Authorities on Developing Sustainable Tourism*. Madrid: United Nations World Tourism Organisation
- UNWTO (2000) *Public-Private Sector Cooperation. Enhancing Tourism Competitiveness*. Madrid: United Nations World Tourism Organization
- UNWTO (2001) *Tourism 2020 Vision. Global Forecasts and Profiles of Market Segments*, Volume 7. Madrid: United Nations World Tourism Organisation
- UNWTO (2004) *Indicators of Sustainable Development for Tourism Destinations: a Guidebook*. Madrid: United Nations World Tourism Organisation

UNWTO (2005) *Tourism Market Trends 2005*. Madrid: United Nations World Tourism Organisation

UNWTO/IMF (2007) 'Tourism and the World Economy.' <http://www.unwto.org/facts/eng/economy.htm>. Madrid: United Nations World Tourism Organisation and International Monetary Fund. Date of Access: 12 June 2007

Woodhill, J. (2005) *Facilitating Complex Multi-Stakeholder Processes. A Societal Learning Perspective*, unpublished working document. Wageningen: International Agricultural Centre

World Bank (1987) *Environment Growth and Development*, Pamphlet No. 14, Development Committee. Washington D.C.: World Bank

About the Editors

Ester Kruk has been working as a Sustainable Mountain Tourism Expert at the International Centre for Integrated Mountain Development (ICIMOD) since February 2005. She worked in the hospitality industry for several years and has over eight years of working experience in the field of international cooperation, as a sustainable tourism adviser and consultant, a researcher in tourism and social sciences, and a programme coordinator for different international organisations. She studied international tourism management and consultancy as well as cultural anthropology and graduated from both studies with distinction. She has published books and several papers on tourism, development, and anthropology; won several academic awards; and conducted a number of training courses on topics in this field. She joined for SNV Netherlands Development Organisation in Lao PDR as Pro-Poor Sustainable Tourism Advisor in September 2007.

John Hummel is Regional Senior Advisor and Network Leader Pro-Poor Sustainable Tourism for SNV Netherlands Development Organisation in Asia. He has been working in different pro-poor and sustainable tourism advisory positions for SNV in the Himalayas, the Mekong, and the Balkans since 1996. In the Himalayas he has worked in the tourism industry, as a tourism development researcher and as development adviser. He has been involved as a trainer and guest lecturer for universities, institutes, and NGOs on topics related to planning and development of eco-, community-based, sustainable, and pro-poor tourism for 15 years.

Kamal Banskota has been Programme Manager of ICIMOD's Agriculture and Rural Income Diversification Programme (ARID) since 2002. Prior to joining ICIMOD, he was with the Centre for Resources and Environmental Studies (CREST), a group that provides consultative services to various international organisations, amongst others on mountain tourism. He has published several books and training manuals on mountain tourism and renewable energy. He was awarded a doctorate in agricultural economics from the University of Alberta, Canada, in 1984. His key areas of interest are in tourism, renewable energy, natural resource management, and environment and poverty and he has been working in these and related fields for the last 25 years.

